

Stepoc Installation Details

The Real Alternative to Shuttered Concrete



General

Stepoc has a grey, paint quality block finish, which is typically covered with paint, plaster or render. In certain circumstances where the appearance is not of primary importance the blocks can be left fair-faced – this is at the discretion of the client.



Stepoc is available in three widths – 200mm, 256mm & 325mm, with each containing a number of components that are typically required to construct the wall. Anderton Concrete provide a set of standard drawings for every project which show the method of constructing corner and end details as well as the setting put positions for the vertical steels.

Tolerances (blocks manufactured to BS EN 15435:2008)

- Height $\pm 2\text{mm}$
- Length $\pm 2\text{mm}$
- Width $\pm 2\text{mm}$

Concrete Mix

The concrete should possess the strength as specified by the structural engineer who is designing the project but be not less than a C32/40, with a minimum slump of 150mm (S4) and a maximum aggregate size of 10mm. The mix should contain no less than 380kg of OPC per cubic metre. Filling of the blocks should be ideally accomplished by a concrete pump and the design of the concrete should take this into account. A reducer nozzle can be used to reduce the flow of concrete.



Alternative methods to pumping may be used, provided that the fresh concrete can flow in a similar manner to pumped concrete. For example, a concrete column skip such as that shown on the right. The method of transportation and placing must not incur an additional risk to the stability of the wall. For this reason concrete should never be discharged or poured at 90° to the wall



To allow initial setting, 24 hours should elapse between pours of concrete. Concrete should finish 50-75mm below the top of the block to provide a key for subsequent courses, with the vertical bars finishing high enough above the concrete to provide the lap specified by the structural engineer. Mechanical Vibration is not required due to the fluid nature of the poured concrete.

The volume of concrete required for each wall thickness is as follows:

- 200 Stepoc 0.12m³ per m² of wall
- 256 Stepoc 0.15m³ per m² of wall
- 325 Stepoc 0.19m³ per m² of wall

Pour Heights

There is a maximum height for each pour so that stability is not lost in the dry laid blocks as the concrete is poured. Lower heights for each pour can also be used dependant on the lift height. The maximum heights are:

- 200 Stepoc 8 Courses = 1.8m
- 256 Stepoc 10 Courses = 2.25m
- 325 Stepoc 10 Courses = 2.25m

We would recommend that during a pour any free ends and corners are temporarily propped to aid the stability especially when filling to the maximum recommended pour height. Backfilling is not recommended until at least 7 days after the pour however the final decision for this should lie with the structural engineer.

Foundations

When casting the foundation, vertical reinforcing bars must be positioned at appropriate centres for each block type, with the frequency to be determined by the structural engineer. The vertical bars should have a minimum of 40mm cover.

- 200mm multiples of 200mm
- 256mm multiples of 133mm
- 325mm multiples of 162.5mm

The foundations should be laid as level as practicable to avoid excessive mortar bedding (max 10mm) on the first course, which is



bedded to a stretched line. The ends of the block should engage the nib of the adjacent block, checking that the blocks are level in both directions. The choice of mortar for the bedding course should meet the exposure conditions and be confirmed by the engineer.

Setting Out

Where the length of a wall is not to a Stepoc module, full length blocks will not be able to be used for the full length of the wall. In addition, the blocks are dry-lay, so the tolerances of the blocks must be taken into account.

Setting out should therefore commence from ends of walls and/or movement joints, working towards central positions. At the finishing points, the blocks from the opposing starting points will butt up to each other (there is no male/male or female/female connector). Some cutting of third/half-length blocks and/or temporary formwork may also be required.

The blocks are stacked dry to a third or half running bond as appropriate to the block size. Check vertical faces for plumb on completion of alternate courses. At openings, full and/or third length plain ends may be used and cut to suit. Alternatively, temporary formwork may be used.

The horizontal reinforcement must be laid in the appropriate groove of the Stepoc block as they are laid. The horizontal reinforcement is tied to the vertical reinforcement using tie wire, typically every third or fourth course to keep the bars in position. The size of reinforcement, and the laps required, should be specified by the structural engineer.

Radius Walls

Radius walls can be constructed using Stepoc with either full length or half/third length units. Tight radius walls can be constructed i.e. Roman end style Swimming Pool detail, however this will require the joint to be opened up and filled with mortar prior to the Stepoc being filled with concrete.

It should be noted that the setting out dimensions for the vertical bars will need to be adjusted depending on the radius of the curve – this should be determined by the structural engineer at the point of design.

For further information and guidance please contact the Anderton Concrete Technical Department on 0333 234 34 34.



Movement Joints

Movement joints should be spaced at centres approximately 20m apart, including corners, but no closer than three block lengths to the corner. The sides of the movement joint are constructed from two plain ends, back to back as shown below. The Movement joint should be constructed 10mm wide for the full width and height of the wall using flexible joint filler with a sealant on the outside edge or edges as shown in the example below. Guidance from the structural engineer should be followed when determining whether or not movement joints are required.

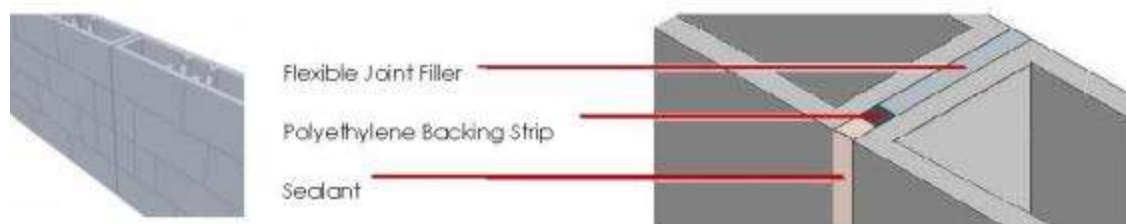

Changes in Height

Changes in height should be staged so that they are a full block height (225mm). Where this is not possible, such as where the ground or the top of the wall is sloped, then full block heights should be used where possible, with temporary shuttering used for the other areas.

Where the required height of the wall is not to a Stepoc module of 225mm there are three options:

1. Raise the finished wall height to that of a full module
2. Use temporary shuttering to form a concrete base to raise the wall the required height so that a Stepoc module can be used
3. Build the wall to the nearest Stepoc module below the required height, and then use temporary shuttering to raise the final wall height as shown on the left

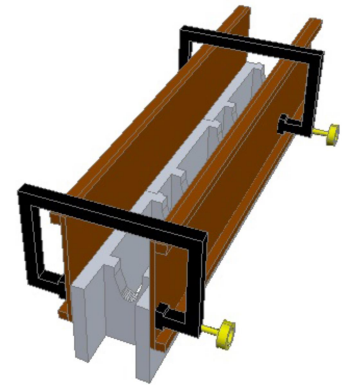

Drainage

Drainage at the rear of basement / retaining walls should always be considered. If Stepoc is being used as a retaining wall, it is recommended that drainage is designed by the structural engineer and be appropriate for the particular situation.

It is possible to incorporate weep holes in a Stepoc wall and we would suggest this is carried out prior to the wall being filled. The use of plastic PVC pipes is recommended, however other preparatory methods can be used.

Waterproofing

Waterproofing should be carried out in line with a specialist contractor's guidance and be suitable for the type of construction. Where a habitable room is being constructed waterproofing should be incorporated in line with the guidance set out by the NHBC or other approved warranty provider.

Junctions with Existing Structures

Where the Stepoc wall runs into an existing wall it can be started as a Terminal End, with wall ties connecting to the existing wall as a typical movement joint detail. Alternatively, the Stepoc wall can butt up to the existing wall using full length and third length standard blocks (trimmed to suit), with holes drilled into the existing wall to allow horizontal bars to form a key (where possible). This can also be used at a T-Junction, though if both walls are built up at the same time notches (similar to those used at corner details) can be cut into the ends and side walls of the blocks to allow a flow of concrete as well as the horizontal reinforcement.

Wall Ties

Wall Ties can be coursed in with the Stepoc wall by nicking the top of the Stepoc block using an angle grinder and then placing the wall tie into the nick. The size of the nick can be adjusted to suit the size of the wall tie. Other types of wall tie can be used i.e. drill and fix or sliding anchor. These should be specified by the engineer or architect designing the scheme.

Double Thickness Stepoc

Where a thickness other than 200mm, 256mm or 325mm is required, this can be achieved by laying blocks side by side. To ensure a strong bond between the two, the side walls can be knocked through (at spacing's recommended by the structural engineer) and the horizontal reinforcement can be looped around the vertical reinforcement (as shown below).

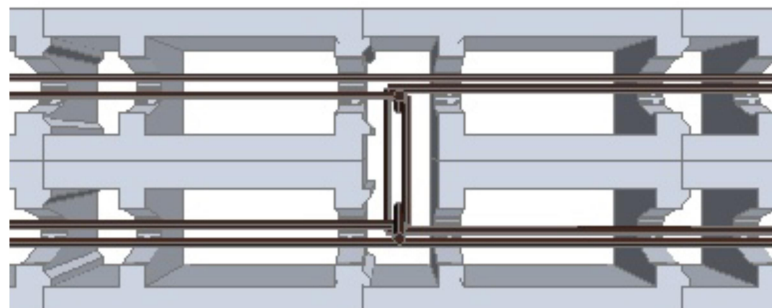

Stepoc Quantity Calculations

The calculations for Stepoc use a figure of 11.11 blocks per m² for the 200 and 256 Stepoc blocks, and 13.67 blocks per m² for the 325 Stepoc. The number of third/half-length standard, plain end and (for 200 and 256 Stepoc) third length plain end blocks are then calculated for the corners, end details and other junctions such as openings, and then subtracted from the full length standard block quantity.

Anderton Concrete provides a service for calculating the number of blocks required for a project based on customer drawings or alternatively there is a block calculator on the website (www.andertonconcrete.co.uk).

Please send drawings to:

Structural Product Sales Team,
Anderton Concrete Ltd,
Units 1&2 Cosgrove Business Park,
Soot Hill,
Anderton
Cheshire
CW9 6AA

or via email to structural@andertonconcrete.co.uk