

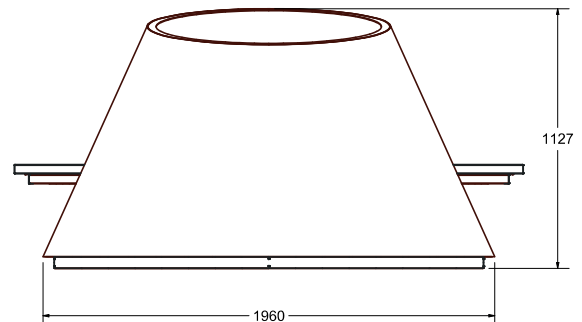
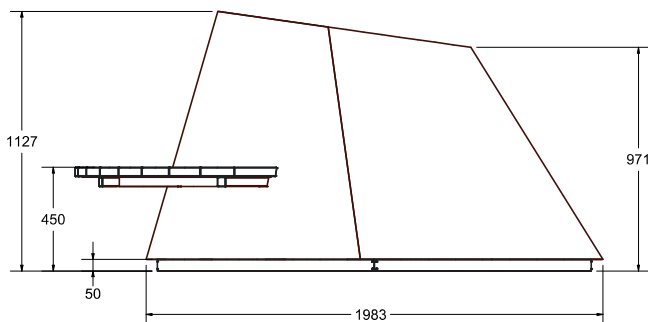
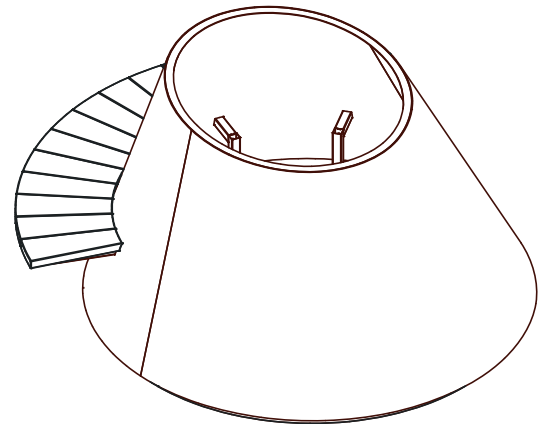
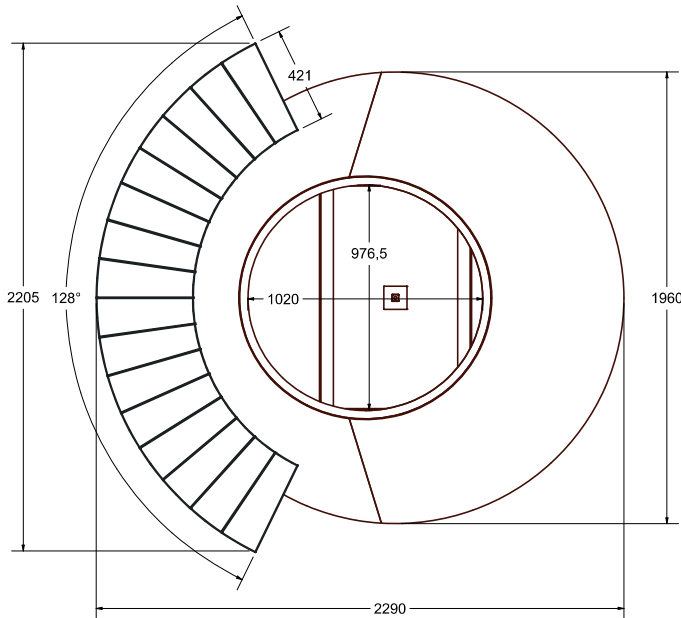

Dimensions:

Height: 1127 mm | Height of the seat: 450 mm | Depth of the seat: 421 mm
 Maximum dimensions: 2205x2290 mm | Ground Dimensions: 1983x1960 mm
 Height Base: 50 mm | Weight of steel: 280 Kg | Capacity: 1780 lt

**Description**

The NECK planter is made in steel 30/10 thickness. To obtain the peculiar conical shape characterizing the planter, the steel sheets go through a specific calendaring and are later welded through continuous welding. On the perimeter of the upper side a band of 35 mm 30/10 thickness is welded. On the bottom of the planter there are 3 drain pipes, made in steel, section 30x30x2

H 50 mm. Under the planter there's a base for the correct leveling. The base is covered with a stainless steel AISI 316 band 15/10 thickness. The seat is made with 16 exotic wood elements 40 mm thickness, 420 mm length, 170 mm maximum width, fixed with specific screws to a laser-cut plate 30/10 thickness. The plate is welded to supports made in tubular steel with section 40x40x2mm. For the realization of this product, Steel EN10111DD11 is used and later treated with a cycle of sandblasting, cathaphoresis and powder coating. Such cycle is meant to guarantee the protection of the painted products, in an environment of C4 corrosion class, as requested by the UNI regulations EN ISO 12944-2. The products are eventually polyester-powder coated with RAL colours at choice. The wood used is either Iroko or Okume, treated with natural, water-repellent, UV ray resistant oils.

LAB23

NECK

Planter

