



Petra 1

Barcas de hormigón ancladas en tierra firme.

Barques de formigó ancorades a la terra ferma.

Concrete boats anchored on land.

Bateaux en béton ancrés à terre.

Barche di calcestruzzo ancorate a terra.

Betonboote, fest im Boden verankert.

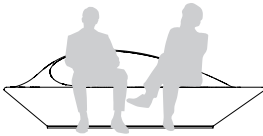

sassi

by Ton Riera

TECHNICAL CHARACTERISTIC

Manufactured product technical features are validated by officially approved laboratory tests.

- **Freeze resistance** 25 cycles of ice (-25°C) / defrosting (+15°C) without fissures, layers nor scaling having occurred.

- **Flexural and compressive strength** (UNE EN 1015-11 (196-1):

Flexural: 78 kgf/cm² (average value among the different standard colours)

Compressive: 440 Kp/cm² (average value among the different standard colours)

Colours

> Standard colours [without coloured pigments]
 grey [1] | white [2] | ochre [3]

> Other colours (with coloured pigments) on order.
 Percentage increase according the colour characteristics and the order request.

Finished

Scoured.

Anti-graffiti superficial treatment optional.

Water repellents treatment superficial optional.

Manufactured in Architectural Cement

sassi | 1.300 kg

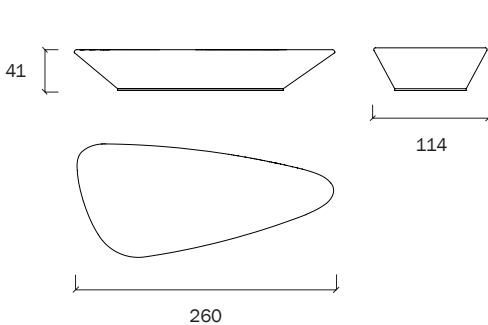

sassi R | 1.600 kg

