

PANEL PLANTER SYSTEM

PRODUCT SPECIFICATION



■ The Panel Planter System is designed primarily as a light weight option that is free-standing and ideal for use where site excavation is not always possible or required.

■ This system is commonly used on roof gardens and terraces.

■ This solution comprises vertical Naturally Very Durable Hardwood components fixed to a Galvanised frame supplied in panel form.

■ This system can be specified to any shape, radius, size and height. It is ideally suited to producing curved and sweeping shapes, fully tailored to your design.

■ Available in straight or curved configurations to meet your bespoke requirements.

■ Supplied in pre-fabricated clad panels for simple and quick on-site bolt together assembly.

■ Can be used as walls or complete planters.

■ Clad to all or visible faces only.

■ This flexible system is tailored to your individual requirements and can be supplied with, or without, a wide range of straight or curved coping options.

- No Coping
- 90 x 40 Coping
- 140 x 40 Coping
- 140 x 65 Coping
- 190 x 90 Coping

■ Available in FSC Certified Hardwood.



scan for the
woodscape
website



The mark of
responsible forestry

Woodscape products are manufactured from Naturally Very Durable Hardwoods, sourced from sustainable forests, as standard. As an FSC® certified supplier we can manufacture our products using FSC certified timber as required.

PANEL PLANTER SYSTEM

PRODUCT SPECIFICATION

Technical Data: Typical Panel Planter System - Straight with vertical slats.

Please contact Woodscape for standard or bespoke detailed customer drawings.

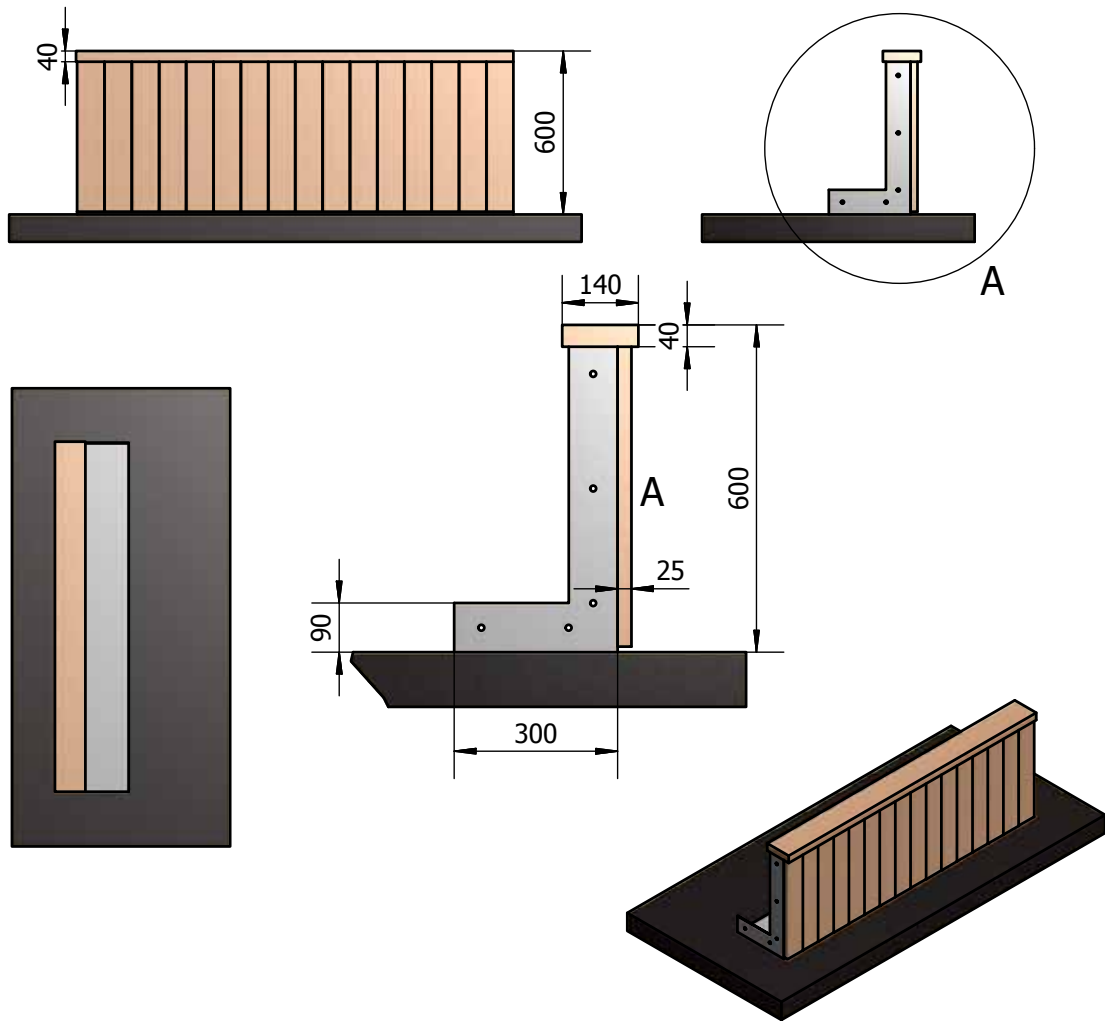

PANEL PLANTER SYSTEM

PRODUCT SPECIFICATION

Technical Data: Typical Panel Planter System - Curved with vertical slats.

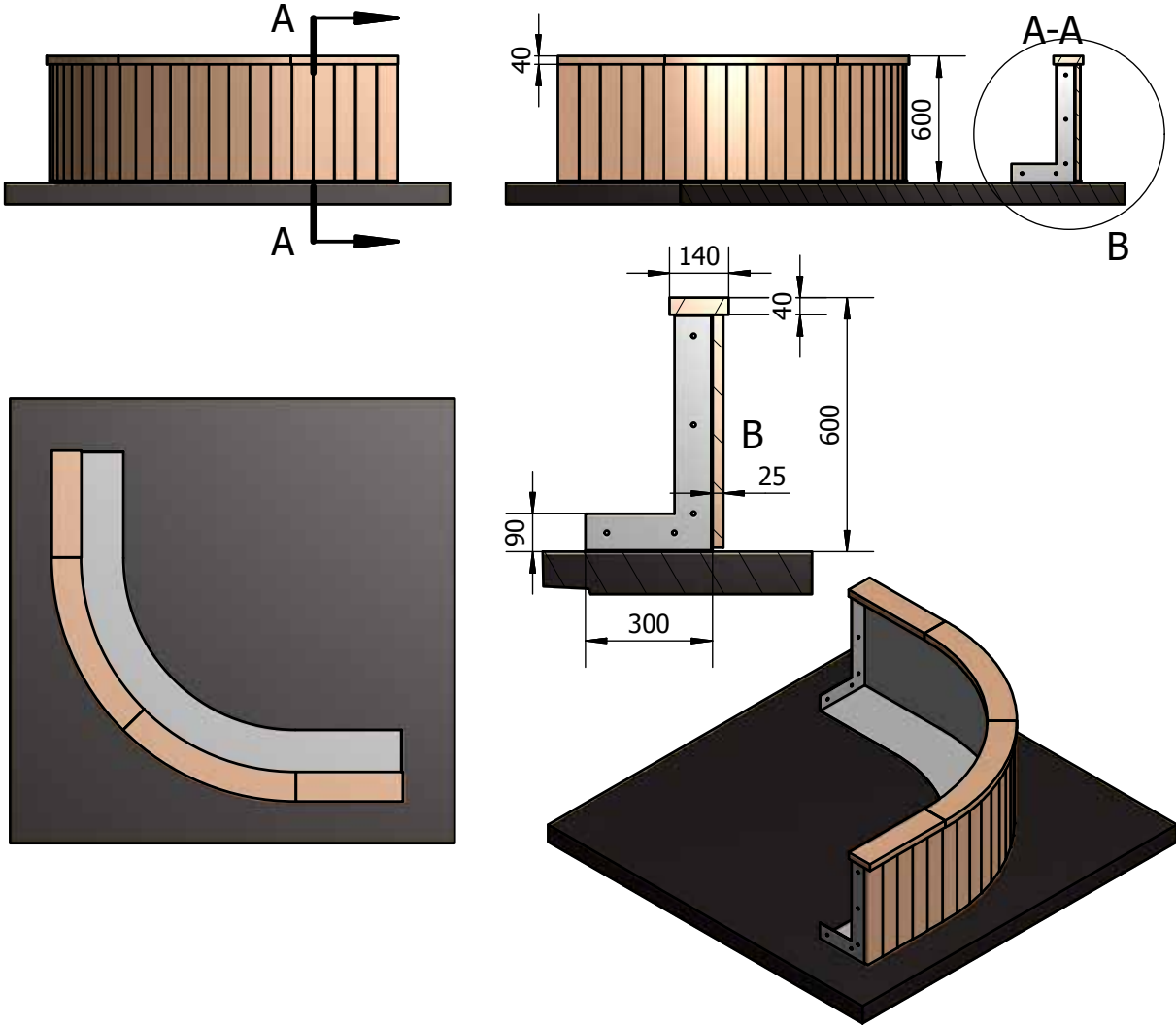

PANEL PLANTER SYSTEM

PRODUCT SPECIFICATION

Technical Data: Panel Planter System - Straight with horizontal slats.

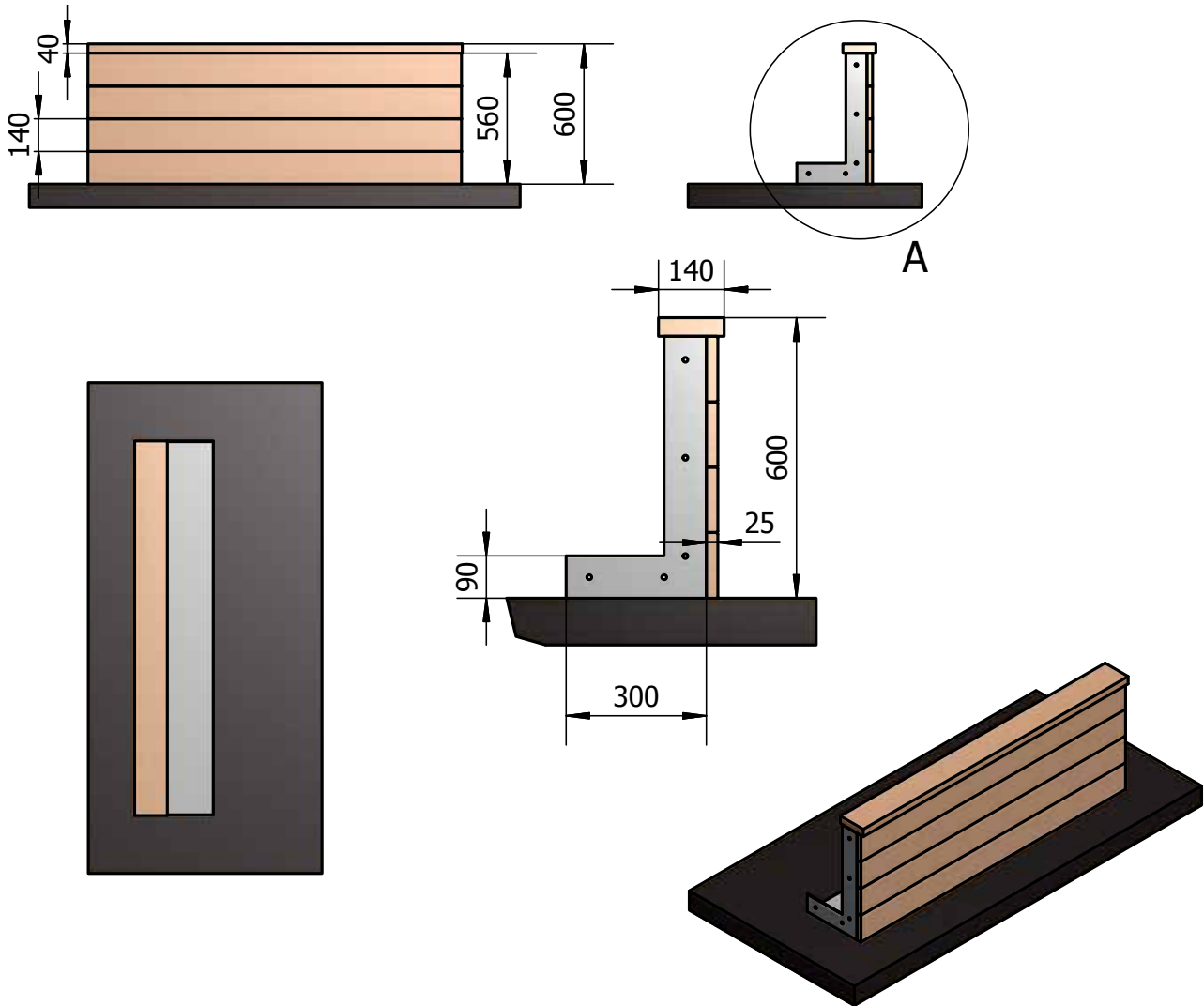

Technical Data: Panel Planter System with integrated seat.

