

WOOD BLOCCX

LANDSCAPING

Lochaber Modular Components

DESCRIPTION

The Lochaber Range has been designed as a completely modular bench and planter solution. Each element can be used independently or together to create any number of combinations.

The Lochaber Range offers curved planter sections of 30°, 45°, 60°, 90° and 180° along with a 45° angled element. Standard bench sections come at 450mm and 1500mm but can be changed to suit any project.

For a free bespoke design contact:
design@woodbloccx.co.uk

NBS SPECIFICATION

Q50 Site/Street Furniture/Equipment Specification

205 Modular Raised Planters

System Outline

Product Reference - **WBX-018**

PRODUCT CAPPING OPTIONS

Standard (W 100 mm x H 50 mm)

Flush (W 75 mm x H 50 mm)

MATERIAL

Scottish pine

Available in Accoya® 



British Association of Landscape Industries



Tel: 0800 389 1420 Email: admin@woodbloccx.co.uk Web: www.woodbloccx-landscaping.com

WoodBlocX Ltd, Old Evanton Road, Dingwall, IV15 9UN

Lochaber Modular Components

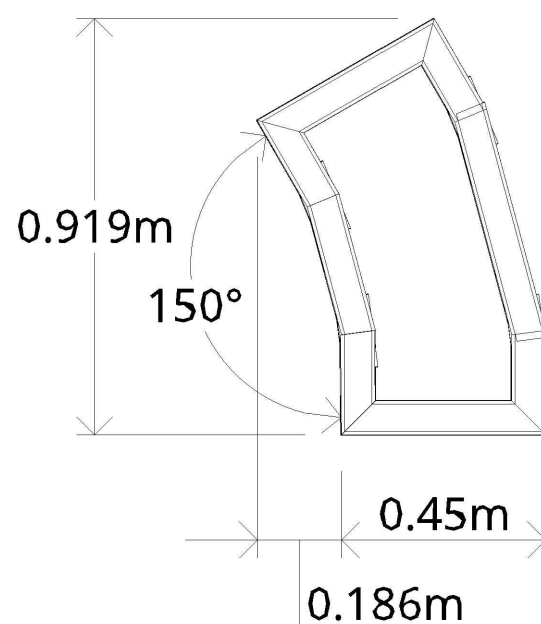
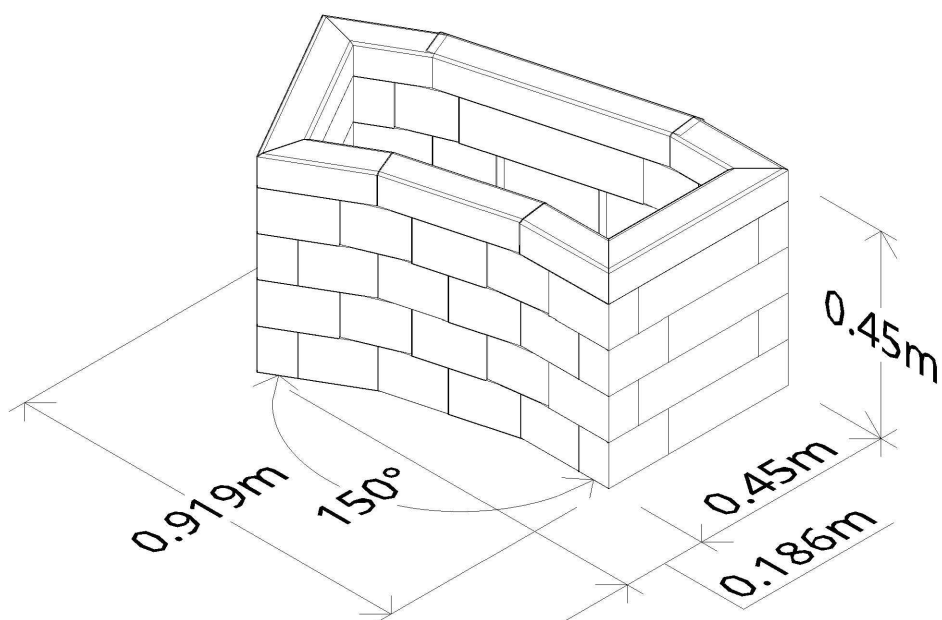
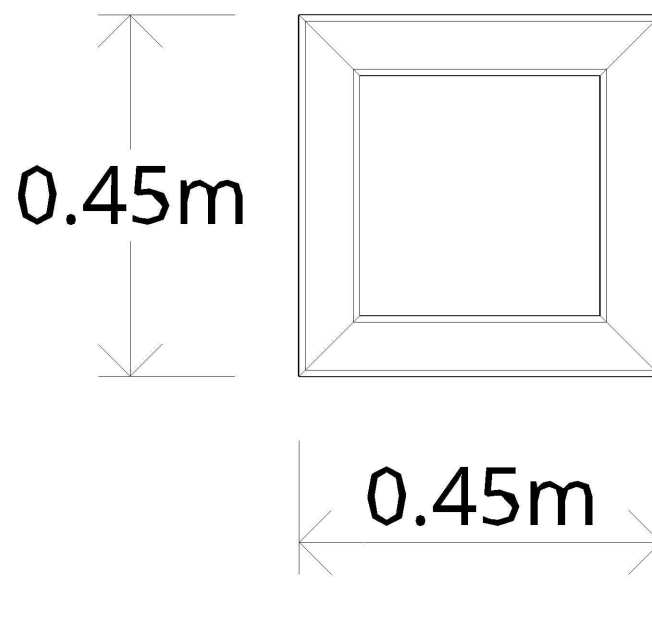
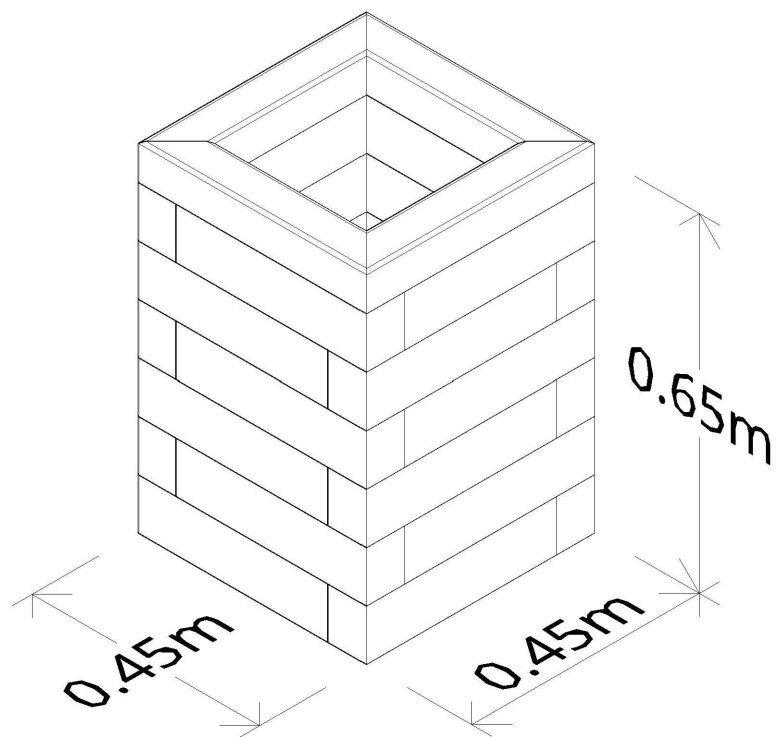
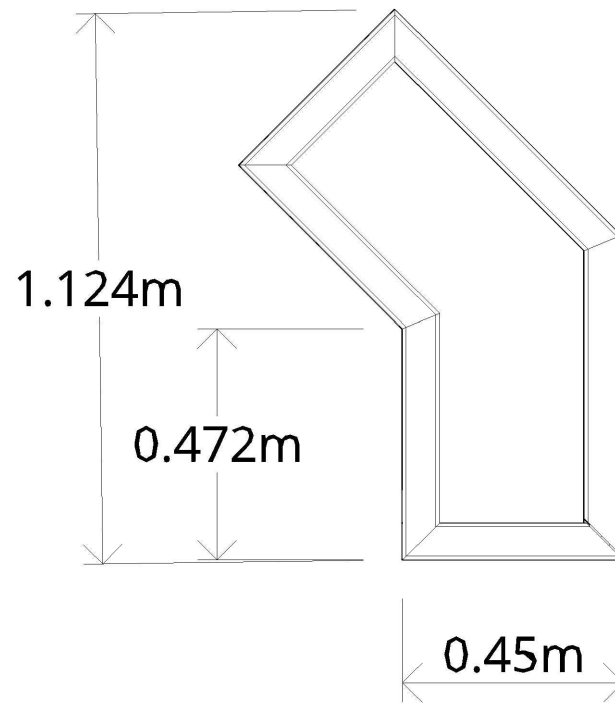
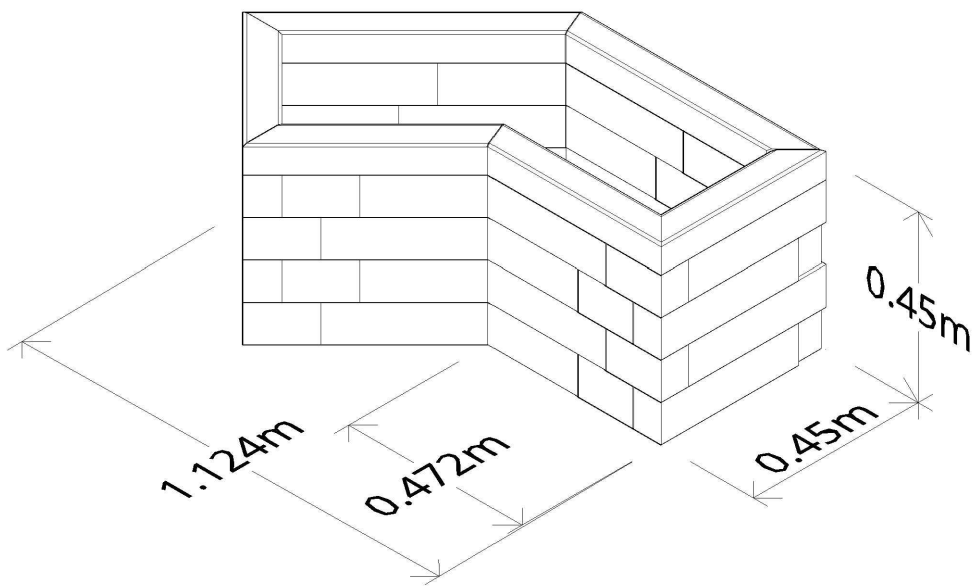

Lochaber Modular Components

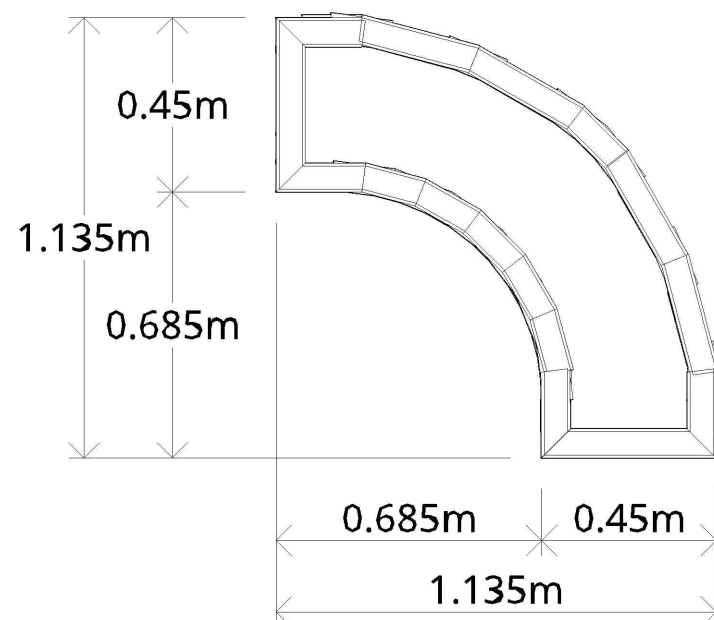
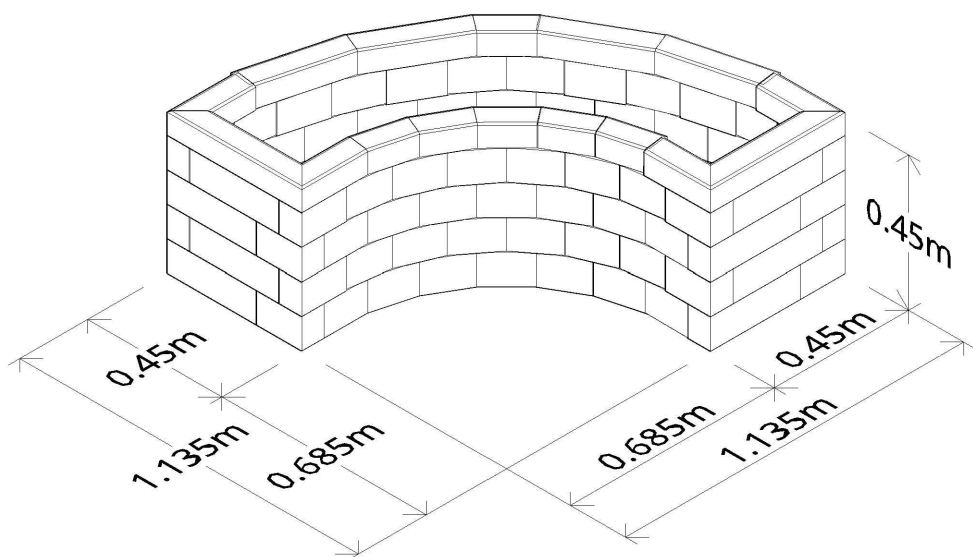
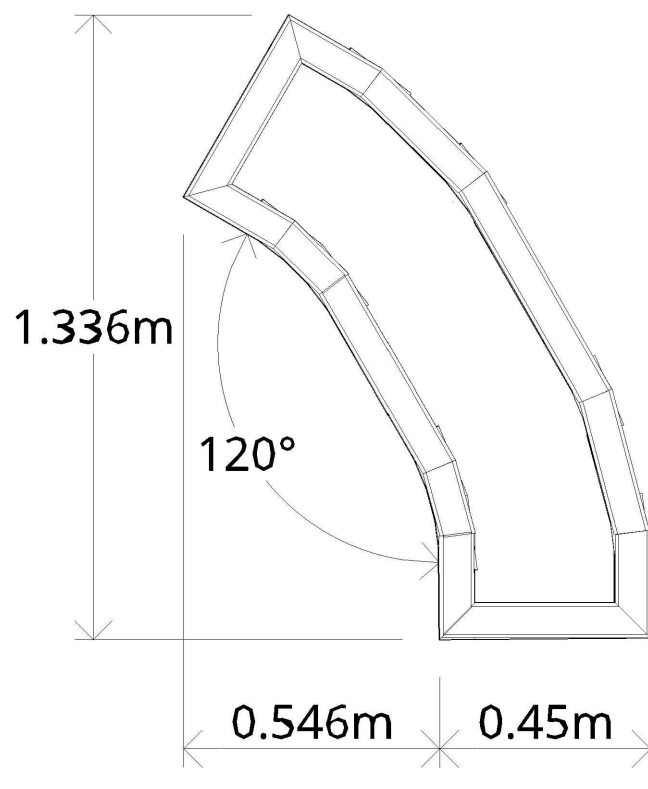
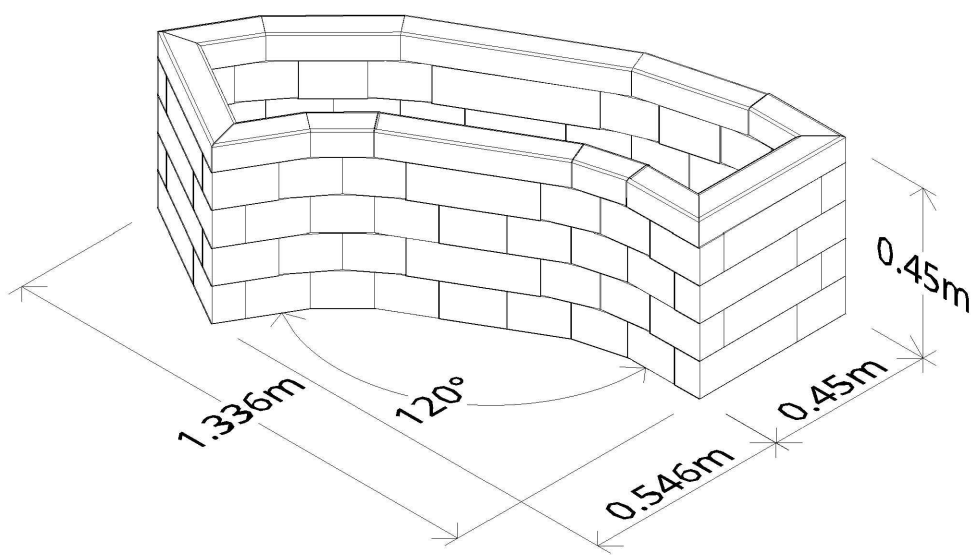
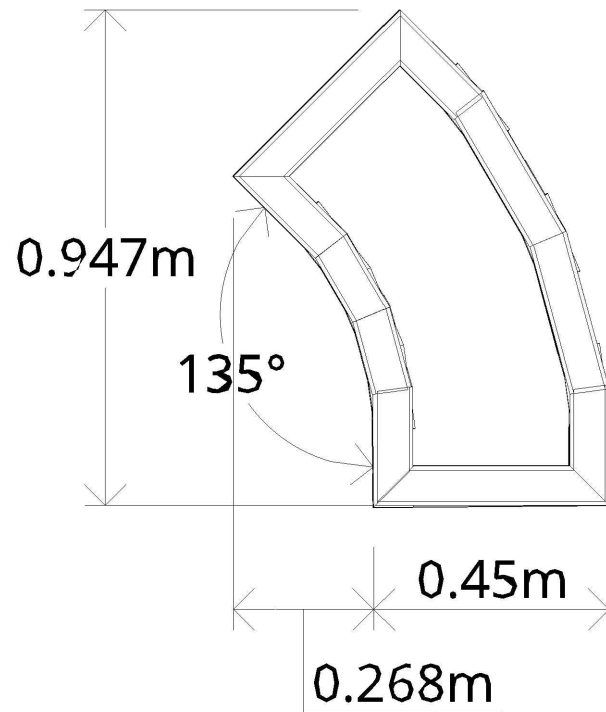
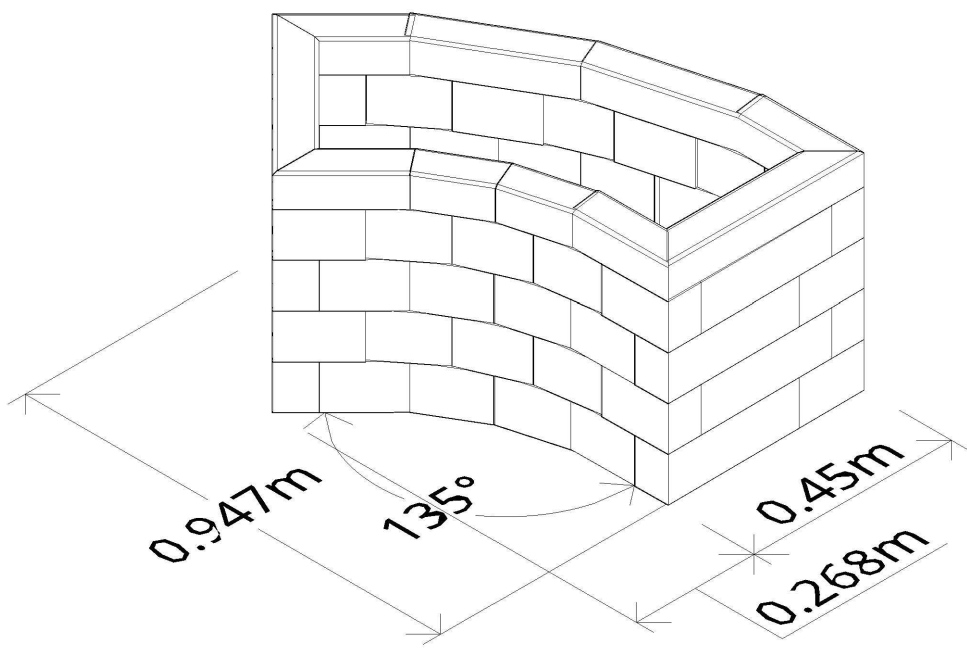

Lochaber Modular Components

