

FACTORY FURNITURE

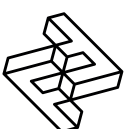

Tree Bench & Seat - Straight

OPERATION & MAINTENANCE MANUAL



Introduction

Design

Design, shop drawings and development by Factory Furniture Ltd.

Manufacture

Factory Furniture manufactured components. Products are assembled in Factory workshops, checked and dispatched ready for installation. Replacement products or components thereof should be ordered direct from Factory Furniture Ltd.

Copyright

The design copyright for the product and drawing copyright remains the sole property of Factory Furniture Ltd.

General Specifications

Straight Bench

Metric length 2000mm | width 525mm | height 450mm*
Imperial length 6' 6½" | width 1' 8½" | height 1' 5½"

*Not including +100mm below ground level for sub-surface fix option

Approx Weight 64kg

Fixing Centres 1450mm (4' 9") x 140mm (5½")

Straight Seat (with back)

Metric length 2000mm | width 525mm | height 785mm*
Imperial length 6' 6½" | width 1' 8½" | height 2' 7"

*Not including +100mm below ground level for sub-surface fix option

Approx Weight 104kg (+5kg for armrest option)

Fixing Centres 1450mm (4' 9") x 140mm (5½")

Detailed Material & Finish Specifications

Bench Slats

- Manufactured from FSC® certified tropical hardwood (*other FSC timber options available upon request*)
- Profiled and left untreated as standard (*oil or microporous woodstain treatment available on request*)
- Bench slats supported by and fixed to frame with minimum 6 no. fixing points per slat



Backrest Slats (Seats only)

- Manufactured from FSC® certified tropical hardwood (other FSC timber options available upon request)
- Profiled and left untreated as standard (oil or microporous woodstain treatment available on request)
- Backrest slats held together and fixed to seat with 3 no. concealed zinc-coated mild steel threaded tie rods. Slats separated on tie rods by aluminium spacers and fastened on top by aluminium end caps and underneath by M12 locknuts

Bases / Frame / Armrests (Optional - for seat only)

- Frame, bases and armrests (seat only) manufactured from stainless steel with satin polished finish
- Bases fixed to frame with 2 no. M10 x 25mm button head bolts and locknuts per base
- Anchored via 2 no. resin fixed M10 x 200mm threaded rods and cap nuts per base (surface fix) or 2 no. zinc-coated steel M10 x 75mm sleeve anchors per base (sub-surface fix)
- Where armrests are included 2 no. armrests per seat are threaded onto the tie rods at one end and fixed at the other end to the outer seat slat with 2 no. fixing points.

General Maintenance

(Recommended Schedule & Guidelines)

Daily/Weekly/Monthly (or as adopted)

Visual checks of bench/seat top, back and bases - check all items for superficial or physical damage.

Three Monthly

Clean all items as detailed below check all fixings are seated correctly; inspect timber for serious damage and splinters.

Six Monthly

Secure all fixings; full clean as detailed below; check that bench/seat is firmly secured to the ground.

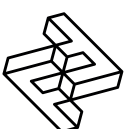

Specific Maintenance Details

FSC Timber

Clean with a stiff brush once per year, especially in more exposed locations, in order to prevent a verdigris type build up on the timber surface. Ideally this should be completed in early spring. During the cleaning stage, all exposed timber surfaces should be inspected for splits and splinters. Any splinters and graffiti should be removed and the surface sanded with 100 grit sandpaper in order to remove any uneven / sharp edges or surfaces.

During the first few months after installation the tannin naturally occurring in the timber may leach out and cause a brown staining on the bases. This may be removed with a light solution of household bleach and water.

Stainless Steel (polished stainless steel only)

Clean as required, but at least every three months, using a stainless steel polish and a lint free cloth. To remove ground in dirt, a stainless steel finishing pad may be required.

Repairs

FSC Timber

For light damage, please see section on specific maintenance details above. For instances of heavy damage, the timber item should be replaced. Please order against the part number reference in the reordering section towards the end of this manual.

Stainless Steel

Light damage (surface scratches etc.) can be removed using an emery pad (240 grit) and freeing oil such as 'WD40'. Care should be taken to follow the direction of the brushing grain. It is recommended that a trial repair be carried out on an unimportant surface first. No corrosive cleaners or other abrasives should be used. Any contamination, particularly carbon steel scuffs from vehicles, should be quickly removed to avoid corrosion.

Heavy Damage

In the event of serious damage to any component, replacements should be ordered from Factory Furniture Ltd. Should further assistance be required (or if the product needs to be disassembled for any reason), please contact Factory Furniture for detailed technical advice.

Reordering / Spares

(Part No. & Item Description)

P1035 / 01

1 no. Slat set (5 slats in total)

P1035 / 02

1 no. Backrest slat set (seat only) (5 slats in total)

P1035 / 03

1 no. Backrest fixing set (set includes endcap, 5 no. spacers and threaded rod)

P1035 / 04

1 no. Tree seat base (please specify surface or sub-surface fix) - suitable for bench & seat

Instructions For Reordering

If possible, please specify job name or number at the time of reordering to enable identification of details such as the original species of timber used, stainless steel finishes and polyester powder coat colours etc. In any event where either, additional orders are required, or spares and replacements are required please contact Factory Furniture Ltd. Using the part numbers given above as reference should help us to process your enquiry more efficiently.

Note - All fittings required to assemble ordered parts will automatically be included in the order

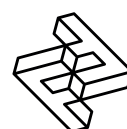

AutoCAD Drawing List

FF1035 / 01

STRAIGHT TREE BENCH
OVERVIEW DRAWING

FF1035 / 02

STRAIGHT TREE SEAT (WITH BACK)
OVERVIEW DRAWING

FF1035 / 03

STRAIGHT TREE BENCH / SEAT
TYPICAL X-SECTION DRAWINGS

FF1035 / 04

STRAIGHT TREE BENCH / SEAT
TIMBER PARTS DETAIL

FF1035 / 05

STRAIGHT TREE BENCH / SEAT
STEEL PARTS DETAIL

FF1035 / 06

STRAIGHT TREE BENCH / SEAT
SET OUT DRAWING

FF1035 / 07

STRAIGHT TREE SEAT (WITH BACK)
ARMREST OPTION

Installation Instructions

All installation works to be carried out by competent personnel - install as complete unit.

Straight Tree Bench / Seat (Surface and sub-surface fix)

1. Install suitable foundation pads (see illustration) each with top face at ground level or 100mm below finished ground level for sub-surface fix.
2. Unpack bases and attach to the seat using 2 no. M10 x 25mm button head bolts per base and tighten to 14Nm
3. Position bench/seat in correct orientation with bases centrally on foundation pads; then mark hole positions through base plates.
4. Remove the bench/seat; drill holes Ø14mm x 200mm deep (surface fix) or Ø12mm x 75mm deep or as manufacturer's recommendations (sub-surface fix).
5. Clear debris from holes.
- 6.a (Surface fix) Fill the holes to within approximately 35mm from the top with Hilti HY150 resin (or similar). Lift the bench/seat (with threaded anchor rods/capnuts in place) and carefully lower the anchors into the holes, leave for two hours to set.
- 6.b Using a torque wrench, tighten nuts and washers over flange plates to 30Nm to fasten down the bench/seat.
7. (Sub-surface fix) Reposition bench/seat unit and fix each base to foundation pads using 2 no. zinc-coated M10 x 75mm sleeve anchors tightened to 50Nm (or as per manufacturer's instruction). Ensure bench/seat remains level during fixing process.
8. Check level & re-instate ground level if necessary (sub-surface fix).

IMPORTANT NOTE

Ensure that stainless steel is protected during site cutting of stone – contamination from disc cutters will produce corrosion on stainless steel components.

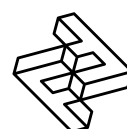

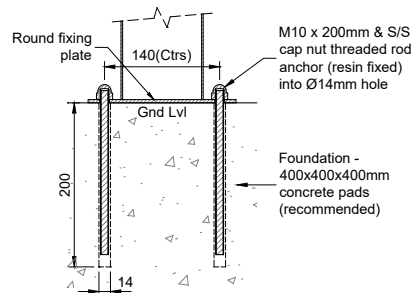
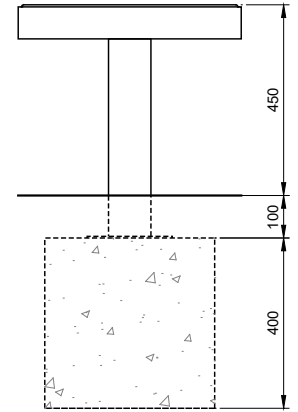
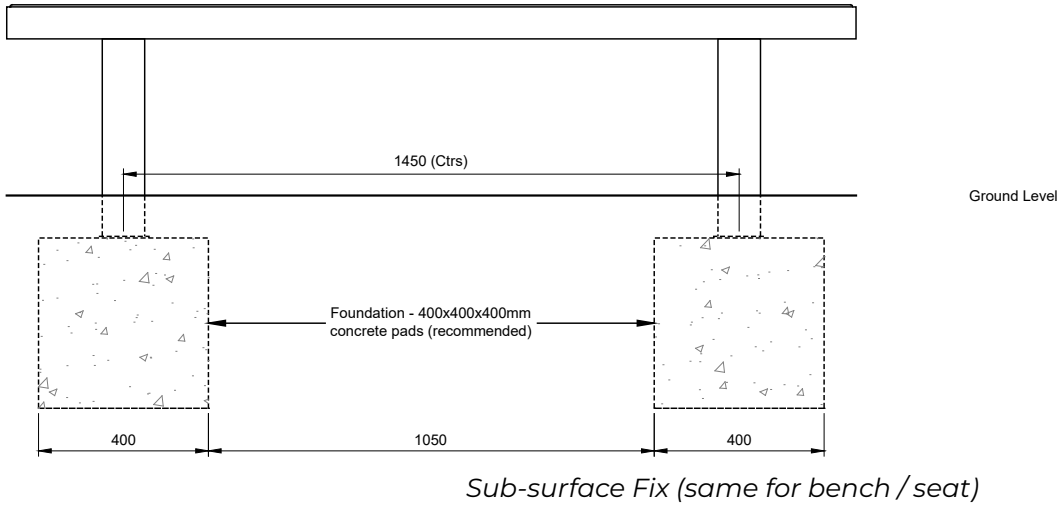
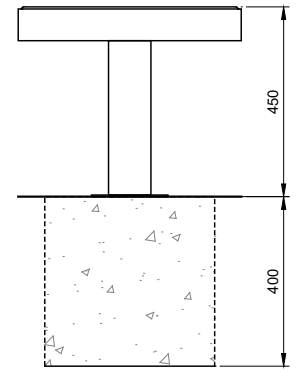
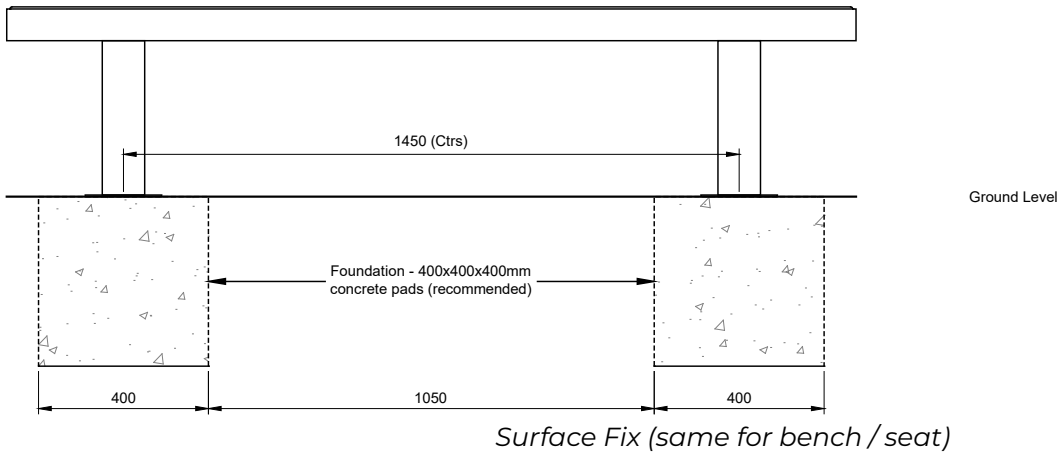

Surface Fix Detail

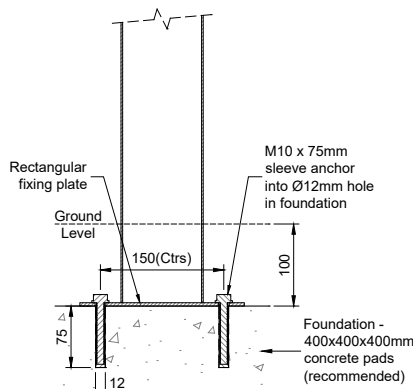

Sub-surface Fix Detail

5 Pioneer Road, Faringdon,
 Oxfordshire SN7 7BU
 +44 (0)1367 242731
 hello@factoryfurniture.co.uk
factoryfurniture.co.uk

