

FACTORY FURNITURE

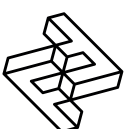

Osso³ Bench

OPERATION & MAINTENANCE MANUAL



Introduction

Design

Design, shop drawings and development by Factory Furniture Ltd.

Manufacture

Factory Furniture manufactured components. Products are assembled in Factory workshops, checked and dispatched ready for installation. Replacement products or components thereof should be ordered direct from Factory Furniture Ltd.

Copyright

The design copyright for the product and drawing copyright remains the sole property of Factory Furniture Ltd.

General Specifications

Osso³ Bench

Metric length 2720mm | width 2385mm | height 470mm *

Imperial length 8' 11" | width 7' 10" | height 1' 6½" *

Approx Weight 124kg

Fixing Centres See installation drawings at end of manual

Detailed Material & Finish Specifications

Main Body

- Manufactured from mild steel - hot dipped galvanised with polyester powder coat finish (*powder coat colour grey as standard or to customer specification*)
- Bench anchored to ground using 6 no. M10 x 75mm sleeve anchors per bench

General Maintenance

(Recommended Schedule & Guidelines)

Daily/Weekly/Monthly (or as adopted)

Visual checks of bench - check all items for superficial or physical damage

Three Monthly

Clean all items as detailed below check all fixings are seated correctly

Six Monthly

Secure all fixings; full clean as detailed below; check that bench is firmly secured to the ground

Specific Maintenance Details

Polyester Powder Coated & Galvanised

For general cleaning using a damp cloth and warm soapy water only. Scourers and abrasive cleaners are NOT suitable for this type of finish and may damage it. Before using any cleaning agents to remove graffiti etc. try on a small, inconspicuous area first to avoid causing more unsightly damage.

Repairs

Polyester Powder Coated & Galvanised Surfaces

For light damage (scratches, chips etc.) repair using touch-up paint to match original colour (available from Factory Furniture Ltd). Paint application should be carried out in accordance with approved methods detailed by the paint manufacturer. Please note that it is advisable to use professional painters to achieve best results when touching up larger areas. Products for respraying larger areas are available from Factory Furniture Ltd.

Heavy Damage

In the event of serious damage to any component, replacements should be ordered from Factory Furniture Ltd. Should further assistance be required (or if the product needs to be disassembled for any reason), please contact Factory Furniture for detailed technical advice.

AutoCAD Drawing List

FF1040 / 01

OSSO³ BENCH

GENERAL ARRANGEMENT DRAWING

FF1040 / 02

OSSO³ BENCH

PART DETAIL DRAWINGS (MAIN BODY)

FF1040 / 03

OSSO³ BENCH

PART DETAIL DRAWINGS (BASE)

FF1040 / 04

OSSO³ BENCH

SETTING OUT DRAWINGS MODULE ASSEMBLY

FF1040 / 05

OSSO³ BENCH

SETTING OUT DRAWINGS BASE FIXINGS

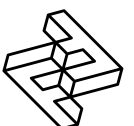

Installation Instructions

All installation works to be carried out by competent personnel - install as complete unit.

Osso³ Bench (surface fix only)

1. If necessary bolt three bench elements together using 3 no. fixing plate spacers and 12 no. M8 x 30mm button head bolts & locknuts provided.
2. Install suitable foundation pads (see illustration) each with top face at ground level
3. Position bench in correct orientation with bases centrally on foundation pads, then mark hole positions through base plates.
4. Remove the bench; drill holes $\text{\O}16\text{mm} \times 75\text{mm}$ deep (or as bolt manufacturer's recommendations). Clear debris from holes.
5. Reposition bench and fix to foundation pads using 6 no. zinc-coated M10 x 75mm sleeve anchors tightened to 50Nm (or as per manufacturer's instruction). Check levels

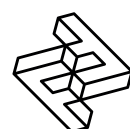
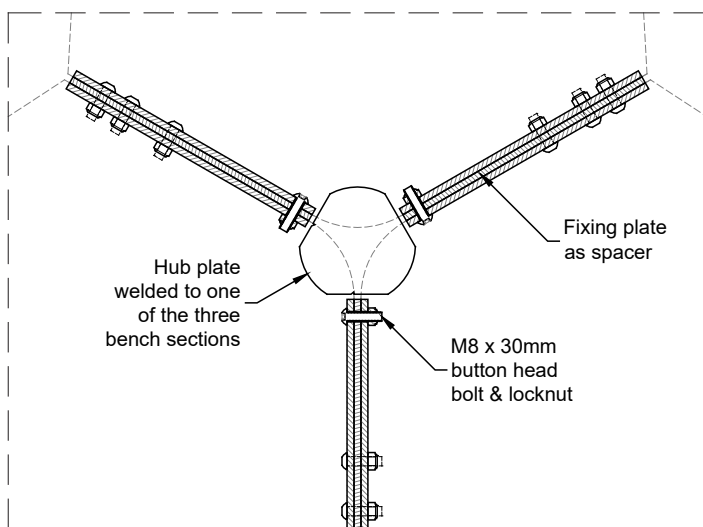

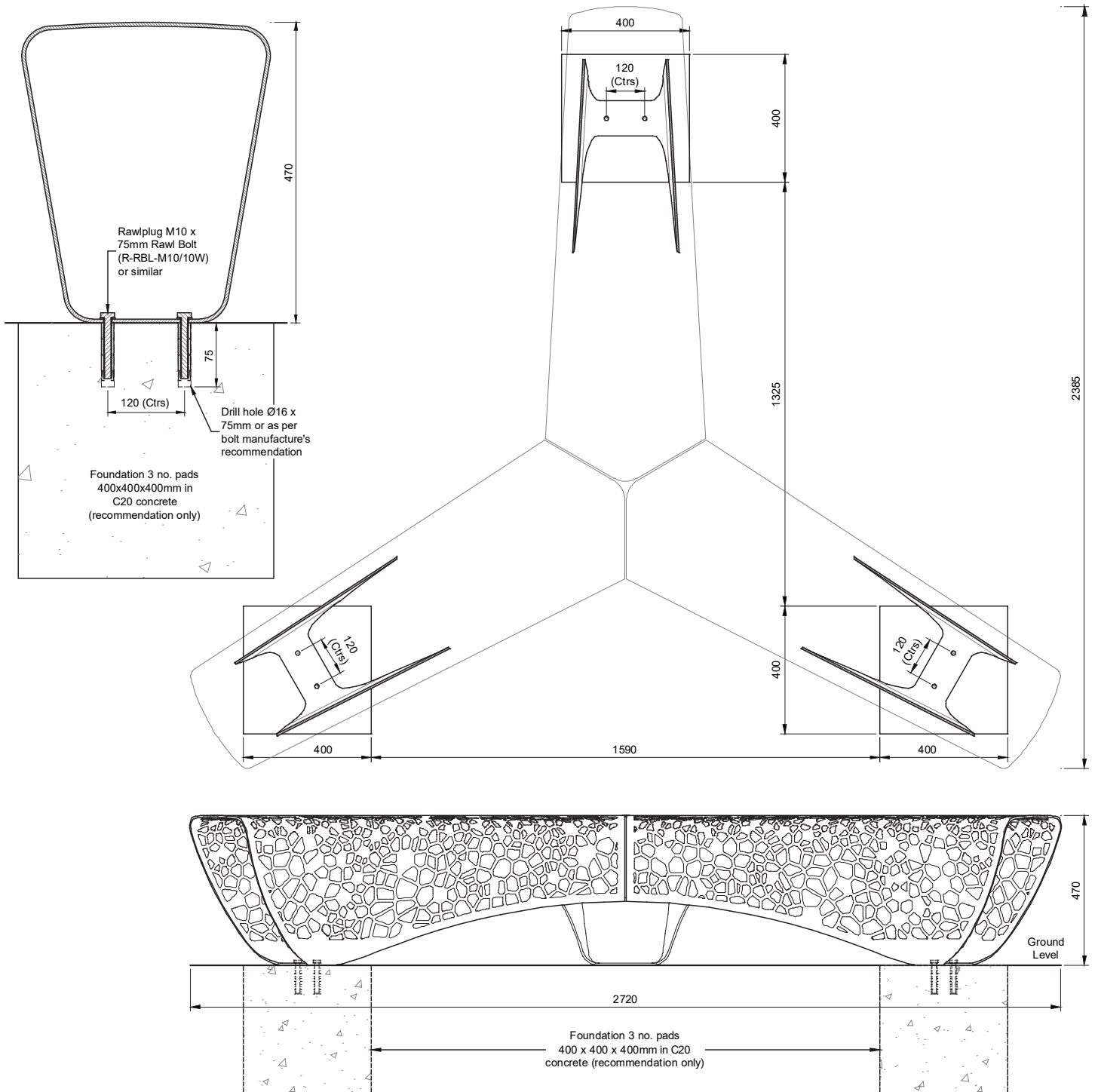

5 Pioneer Road, Faringdon,
 Oxfordshire SN7 7BU
 +44 (0)1367 242731
 hello@factoryfurniture.co.uk

factoryfurniture.co.uk

