



**Fitzpatrick  
Woolmer**

## Bowman™ Option A

Our rustic Oak Option A **Bowman™** information displays offer a highly visible, durable solution, perfect for country parks and nature reserves. Their natural aesthetic blends seamlessly with outdoor environments while standing out for clear visibility.

These displays welcome visitors, provide essential wayfinding, and convey your unique brand message at the point of arrival. This ensures a smooth and engaging start to the visitor journey, enhancing the overall experience and creating a lasting first impression.

### Product features

- \* Hardwood FSC Oak construction
- \* Tamper resistant fixings
- \* Removable graphic panel
- \* Preservative finish
- \* Standard sizes A3, A2, A1 and A0
- \* 1 year manufacturer's warranty

**Fitzpatrick Woolmer Design & Publishing Limited**

Unit 7 Lakeside Park, Neptune Close, Rochester, Kent, ME2 4LT  
 t: 01634 711 771 e: info@fwdp.co.uk w: fwdp.co.uk



By Appointment to His Majesty The King  
 Manufacturer of Signs and Wayfinding  
 Fitzpatrick Woolmer Design & Publishing Ltd, Kent

Specification applies to the standard product. Our range of options usually allow us to accommodate any differences you may require. Please contact us and we will be happy to support you in developing this specification to meet your requirements.

Option delete/ update as appropriate

**Manufacturer:** Fitzpatrick Woolmer,  
 Unit 7 Lakeside Park, Neptune Close,  
 Rochester, Kent, ME2 4LT.  
 Tel: 01634 711 771  
 Email: info@fwdp.co.uk

**Timber:** FSC Prime Grade to BS EN 975-1

**Species:** Oak and Eucalyptus (external grade plywood)

**Origin:** France and China

**Moisture content on delivery:** 10% - 20%

**Certification:** FSC chain of custody

**Finish:** Sadolin Classic wood preservative, solvent based, matt

**Colour:** Light Oak

**Visible fixings:** Stainless steel security fixings to removable parts

**Capacity:** Will accommodate a 3mm thick printed graphic panel

**Weight:** 60kg

**Installation:** Posts extend 600mm below ground level

**Guarantee:** One year manufacturer's warranty

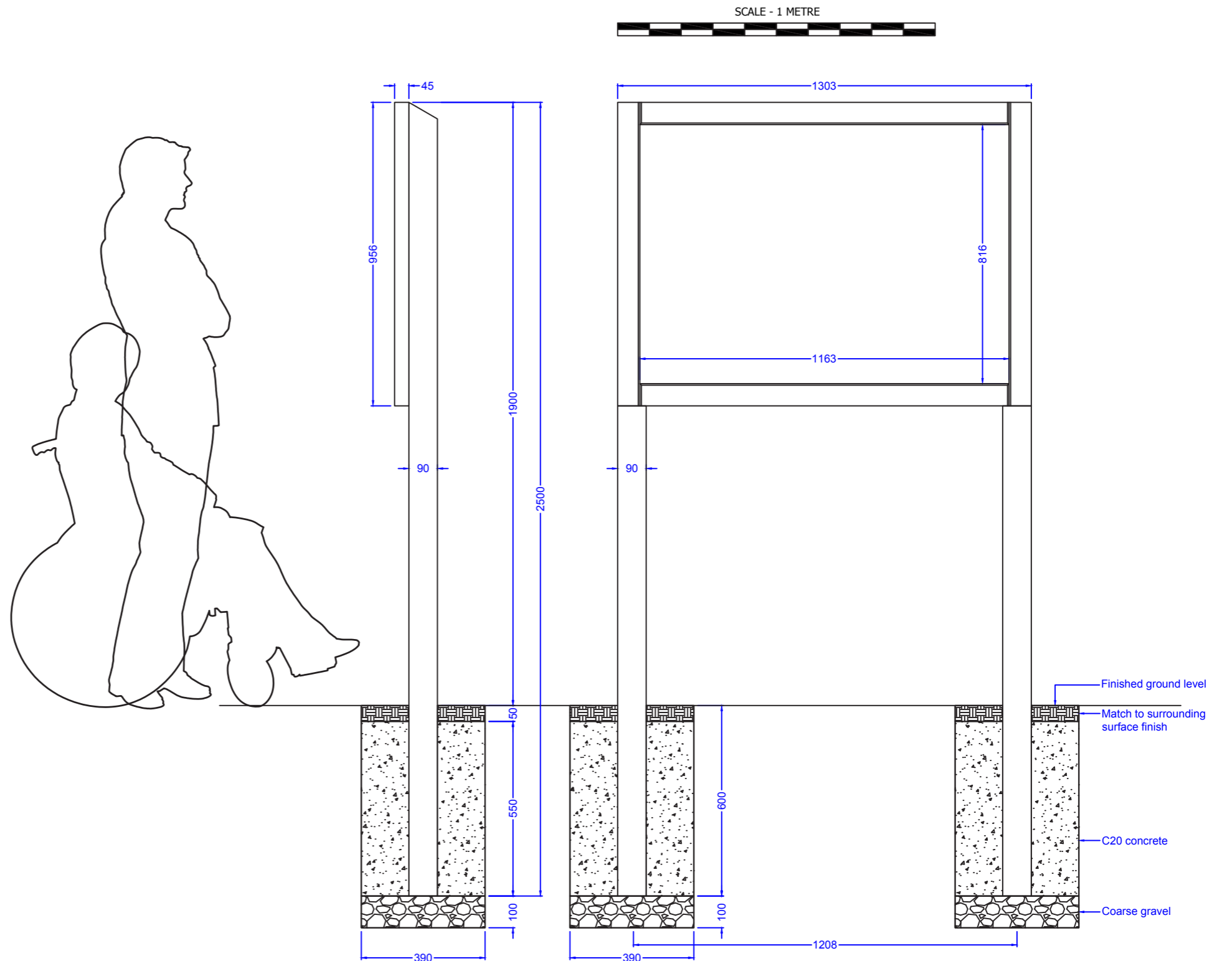
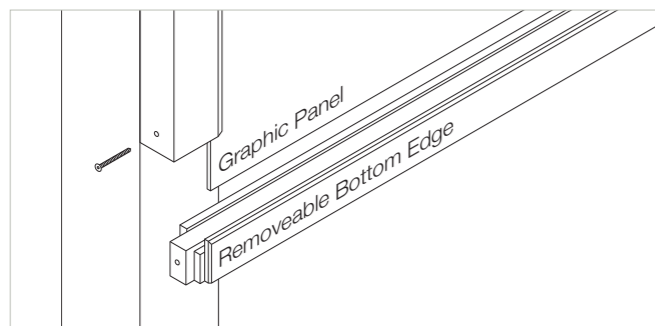

Note: All dimensions are indicative only. Footing details are subject to soil conditions and structural engineers recommendations.

Specification applies to the standard product. Our range of options usually allow us to accommodate any differences you may require. Please contact us and we will be happy to support you in developing this specification to meet your requirements.

Option delete/ update as appropriate

**Manufacturer:** Fitzpatrick Woolmer,  
 Unit 7 Lakeside Park, Neptune Close,  
 Rochester, Kent, ME2 4LT.  
 Tel: 01634 711 771  
 Email: info@fwdp.co.uk

**Timber:** FSC Prime Grade to BS EN 975-1

**Species:** Oak and Eucalyptus (external grade plywood)

**Origin:** France and China

**Moisture content on delivery:** 10% - 20%

**Certification:** FSC chain of custody

**Finish:** Sadolin Classic wood preservative, solvent based, matt

**Colour:** Light Oak

**Visible fixings:** Stainless steel security fixings to removable parts

**Capacity:** Will accommodate a 3mm thick printed graphic panel

**Weight:** 36kg

**Installation:** Posts extend 600mm below ground level

**Guarantee:** One year manufacturer's warranty

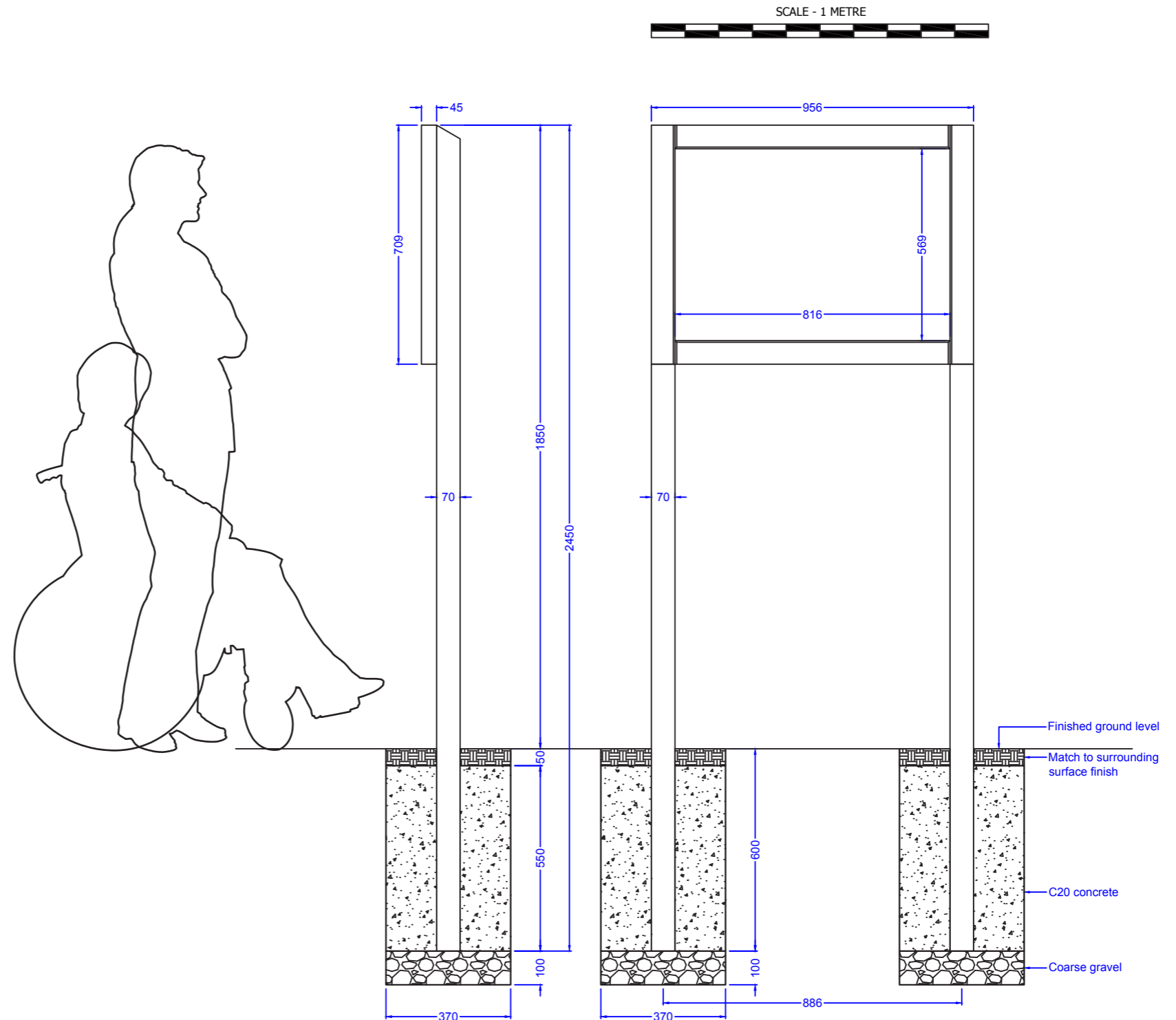
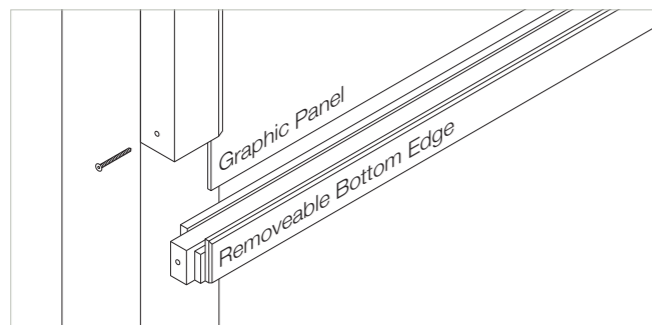

Note: All dimensions are indicative only. Footing details are subject to soil conditions and structural engineers recommendations.

Specification applies to the standard product. Our range of options usually allow us to accommodate any differences you may require. Please contact us and we will be happy to support you in developing this specification to meet your requirements.

Option delete/ update as appropriate

**Manufacturer:** Fitzpatrick Woolmer,  
 Unit 7 Lakeside Park, Neptune Close,  
 Rochester, Kent, ME2 4LT.  
 Tel: 01634 711 771  
 Email: info@fwdp.co.uk

**Timber:** FSC Prime Grade to BS EN 975-1

**Species:** Oak and Eucalyptus (external grade plywood)

**Origin:** France and China

**Moisture content on delivery:** 10% - 20%

**Certification:** FSC chain of custody

**Finish:** Sadolin Classic wood preservative, solvent based, matt

**Colour:** Light Oak

**Visible fixings:** Stainless steel security fixings to removable parts

**Capacity:** Will accommodate a 3mm thick printed graphic panel

**Weight:** 30kg

**Installation:** Posts extend 600mm below ground level

**Guarantee:** One year manufacturer's warranty

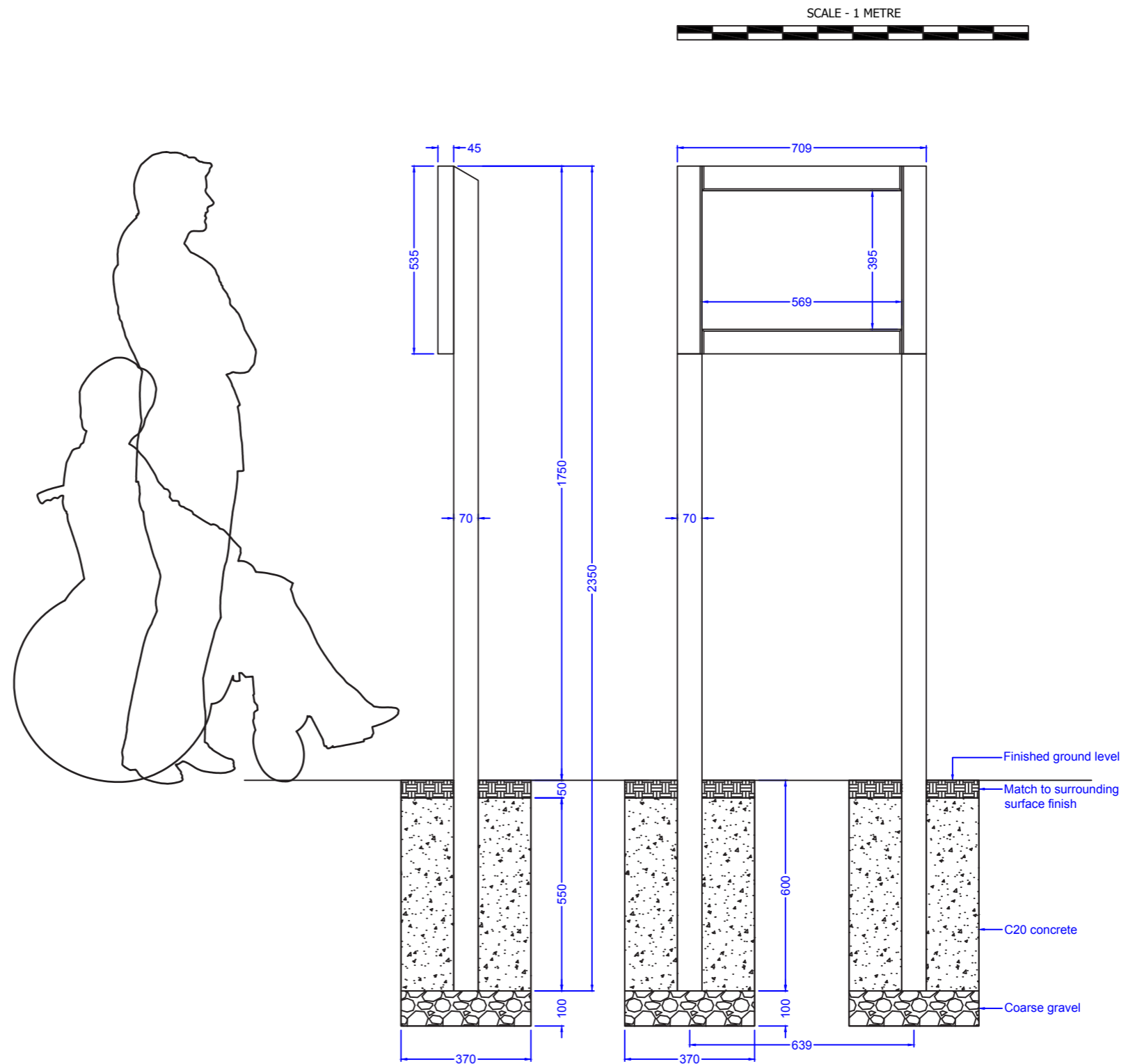
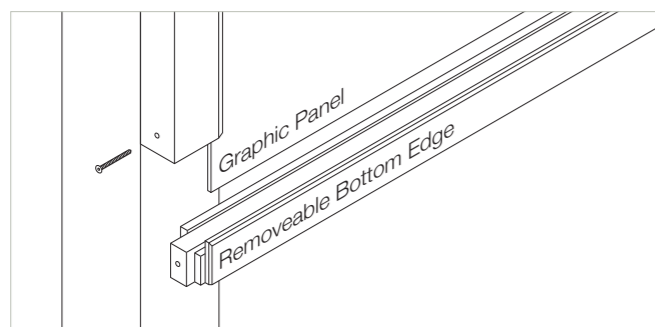

Note: All dimensions are indicative only. Footing details are subject to soil conditions and structural engineers recommendations.

Specification applies to the standard product. Our range of options usually allow us to accommodate any differences you may require. Please contact us and we will be happy to support you in developing this specification to meet your requirements.

Option delete/ update as appropriate

**Manufacturer:** Fitzpatrick Woolmer,  
 Unit 7 Lakeside Park, Neptune Close,  
 Rochester, Kent, ME2 4LT.  
 Tel: 01634 711 771  
 Email: info@fwdp.co.uk

**Timber:** FSC Prime Grade to BS EN 975-1

**Species:** Oak and Eucalyptus (external grade plywood)

**Origin:** France and China

**Moisture content on delivery:** 10% - 20%

**Certification:** FSC chain of custody

**Finish:** Sadolin Classic wood preservative, solvent based, matt

**Colour:** Light Oak

**Visible fixings:** Stainless steel security fixings to removable parts

**Capacity:** Will accommodate a 3mm thick printed graphic panel

**Weight:** 27kg

**Installation:** Posts extend 600mm below ground level

**Guarantee:** One year manufacturer's warranty

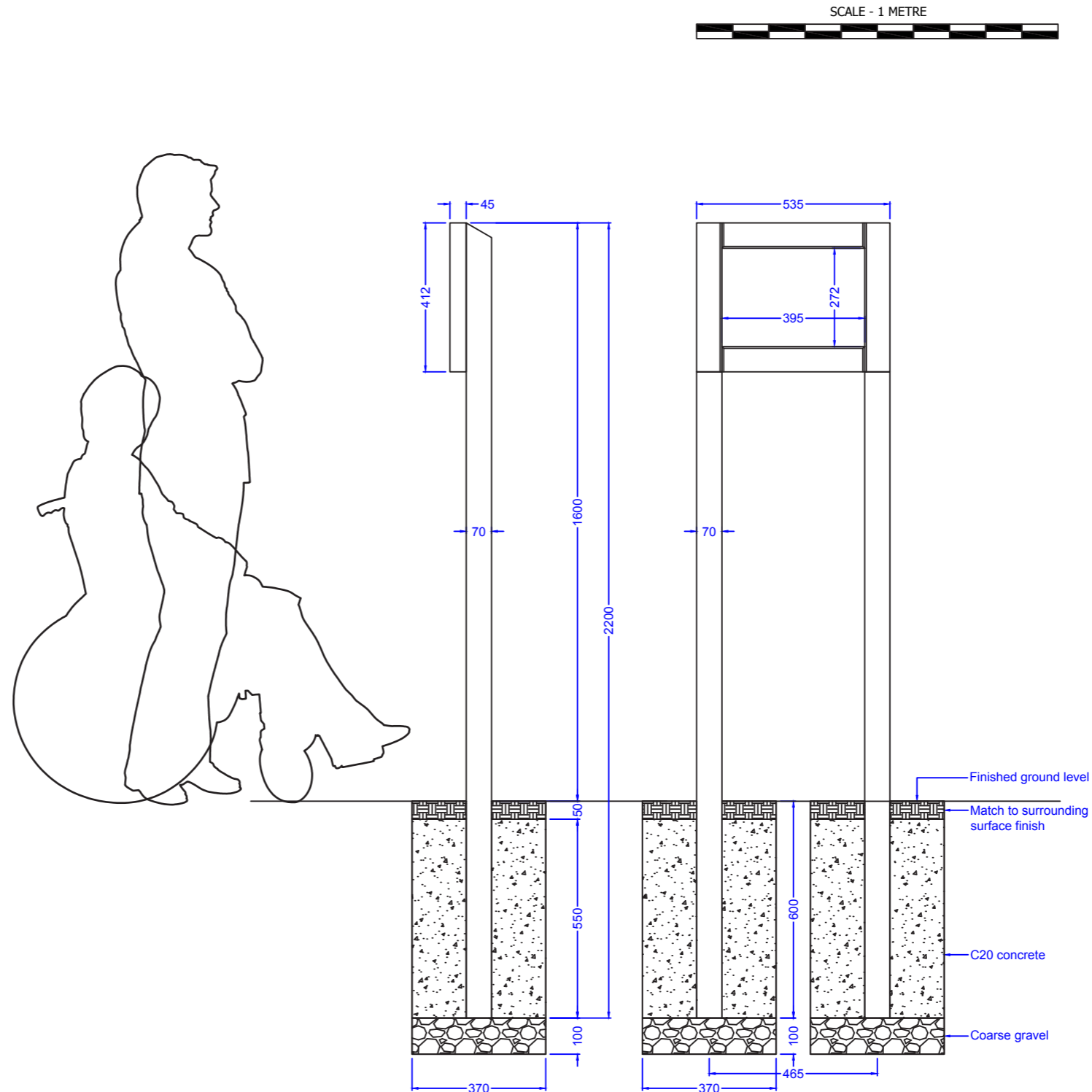
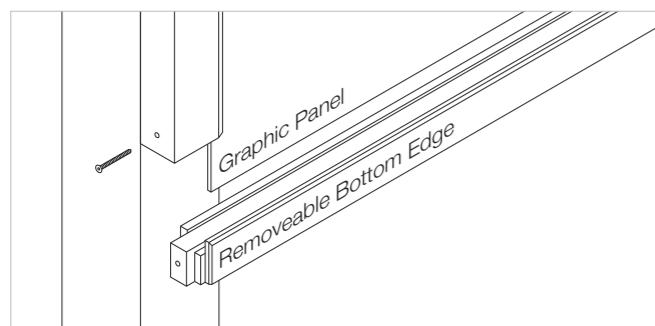

Note: All dimensions are indicative only. Footing details are subject to soil conditions and structural engineers recommendations.