

# FASERFIX®PARK

FASERFIX®PARK, class D 400, Channel, 1.0 m

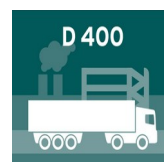

D 400

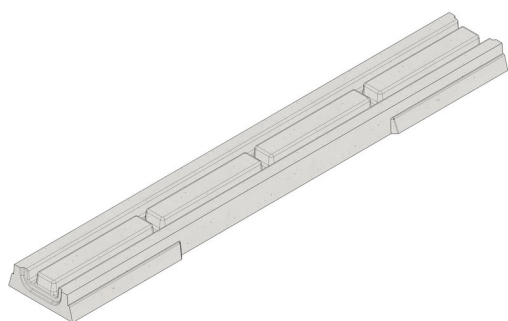
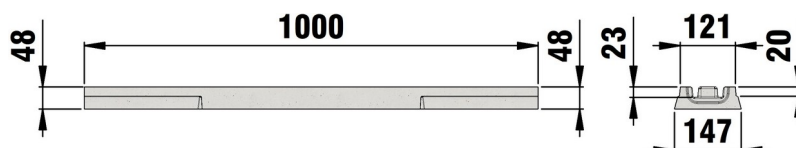

## ■ Technical data:

Length mm	Width mm	Height mm	Weight kg	Inlaying depth	Internal channel cross-sect. cm <sup>2</sup>	Item-no.
1000	147	48	12.82	0	0.0	10100

## ■ Product description:

FASERFIX PARK Evaporation channel made of fibre-reinforced concrete, with longitudinal slots SW 14 mm and cross slots SW 19 mm, load class A 15 - D 400 according to EN 1433, CE compliant, with sealing groove, LxWxH 1000x147x48 mm, item no. 10100

## ■ Material:

- **Channel body:** fibre-reinforced concrete
- **Angle housing:**

## ■ Type acc. DIN EN 1433:

M

## ■ Set of rules:

## ■ Application areas:

- Underground parking

The optimal use of the product in the aforementioned applications depends on various factors (positioning, traffic load and frequency,...). Our experts will be happy to advise you!