

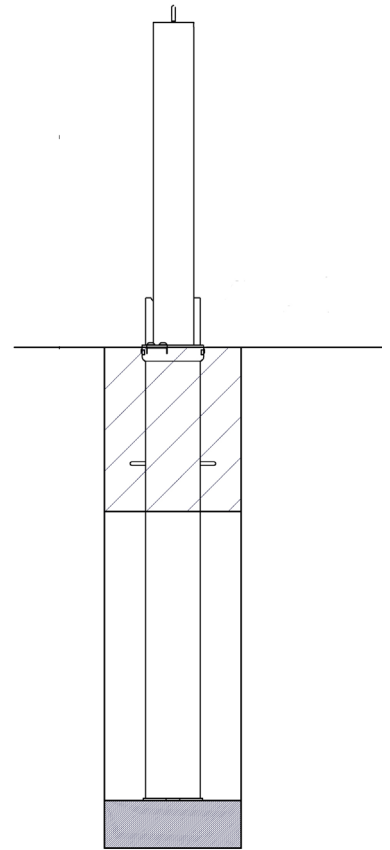

# Square RetractaPost 745

## 745mm

### Galvanised or Galvanised & Colour



The Square RetractaPost 745 is an effective means of preventing unauthorised vehicle access. When not in use, the post retracts into its integrated socket and is covered by the integral lid. The post can be raised to restrict vehicle access and secured with a padlock (available separately).

Simple and unobtrusive, the Square RetractaPost 745 is perfect for use on commercial car parks, vehicle forecourts and domestic driveways. The Square RetractaPost 745 is manufactured from galvanised mild steel and can be colour coated to any standard RAL number (please state RAL number at time of order).

<u>Part Number</u>	<u>Description</u>	<u>Lift Weight (kg)</u>	<u>Weight (kg)</u>
138 130 361	60mm x 60mm Galvanised	6kg	19kg
138 130 366B	60mm x 60mm Galvanised & Black	6kg	19kg
138 130 366Y	60mm x 60mm Galvanised & Yellow	6kg	19kg
138 130 366	60mm x 60mm Galvanised & Colour	6kg	19kg
138 130 401	70mm x 70mm Galvanised	7kg	26kg
138 130 404B	70mm x 70mm Galvanised & Black	7kg	26kg
138 130 404Y	70mm x 70mm Galvanised & Yellow	7kg	26kg
138 130 404	70mm x 70mm Galvanised & Colour	7kg	26kg

#### Product details

- 745mm (Height above ground when raised)
- Other colours can be provided on request (RAL no. to be advised)
- 3mm wall thickness - Galvanised and galvanised & colour
- Socket - 1010mm (below ground)
- Red/White chevron tape available extra

#### Installation & use

AUTOPA recommends that posts are placed no further than 1,200mm apart to ensure that no vehicle may pass between them. An excavated hole (no less than 1,200mm deep and 300mm<sup>2</sup>) is required for installation. Provision for suitable drainage must be made at the bottom of the hole. The uppermost 300 - 400mm must be set into concrete. The lid of the post should be no more than 10mm above finished ground level. This product is guaranteed for 12 months (if installed and used correctly).



[www.autopa.co.uk](http://www.autopa.co.uk)  
+44 (0)1788 550556

AUTOPA Limited  
Cottage Leap, Rugby, Warwickshire CV21 3XP

