



10+



3



1,7m



1 = 3m  
2 = 0,6m  
3 = 2m



Physical inclusion  
Sensory inclusion  
Cognitive inclusion

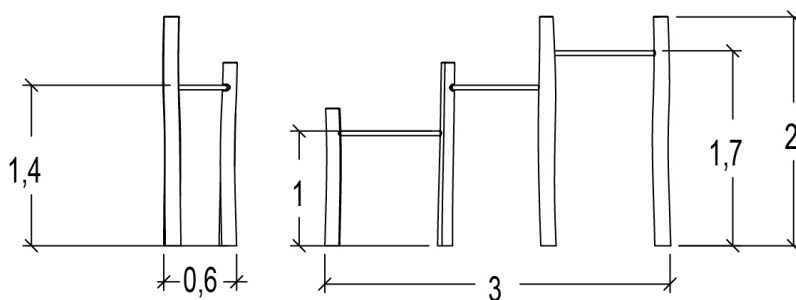
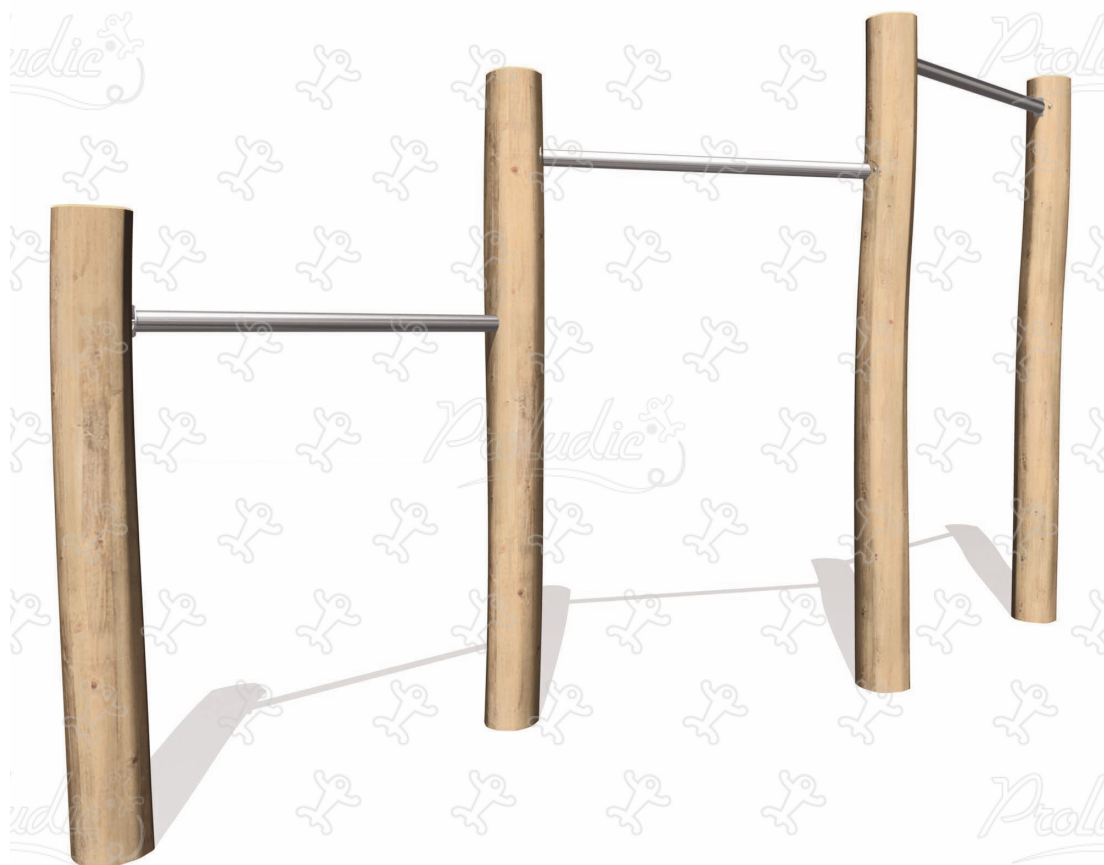

Play value : **3**

hanging



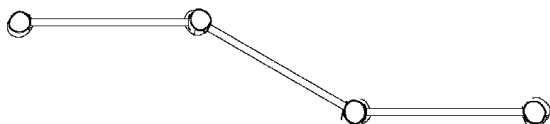

## Components

### 1 Horizontal bars



## Installation of equipment

**IMPORTANT:** It is essential to refer to the installation instructions for information on the size of the safety areas.

-  Impact area (minimum normative surface)
-  Free space

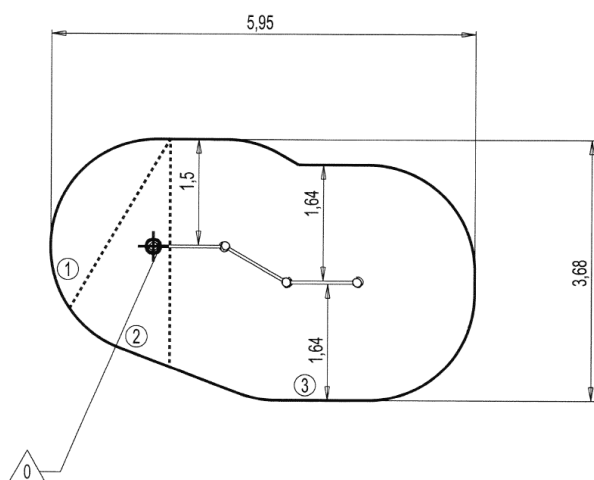

Point de Référence  
Setting Out Point  
Punto de referencia  
Bezugspunkt



1	1m	2m <sup>2</sup>
2	1,4m	2,5m <sup>2</sup>
3	1,7m	13,5m <sup>2</sup>



2



01h00



0.26m<sup>3</sup>



18m<sup>2</sup>



111kg



29kg

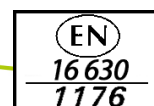

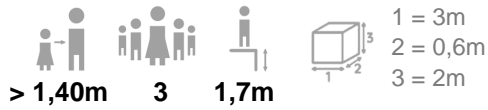

Physical inclusion

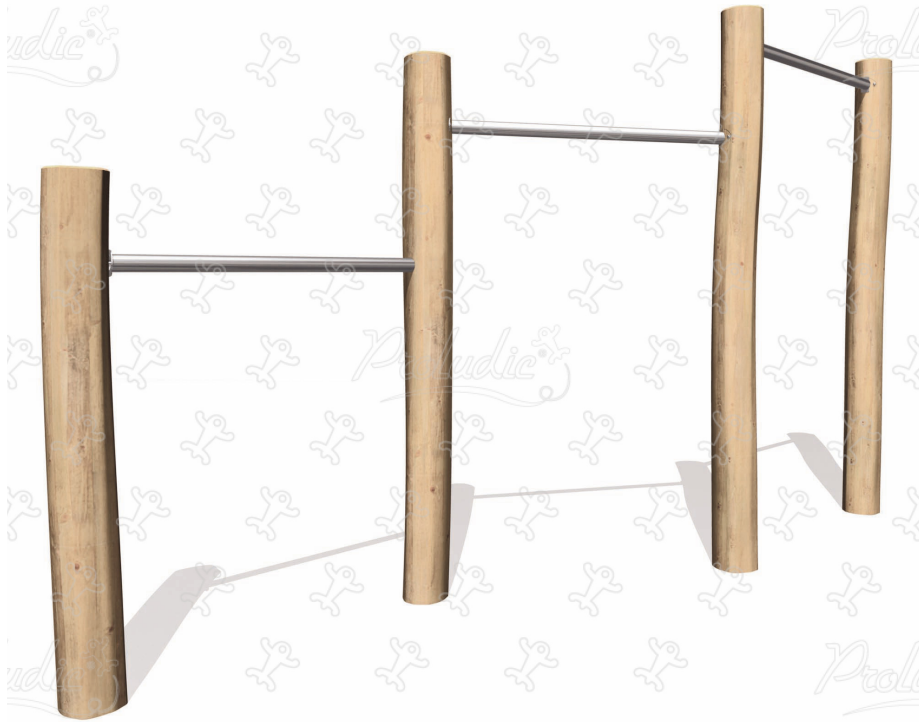

Sports formula

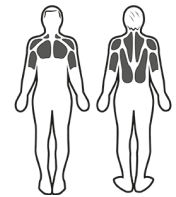

Muscular stimulation

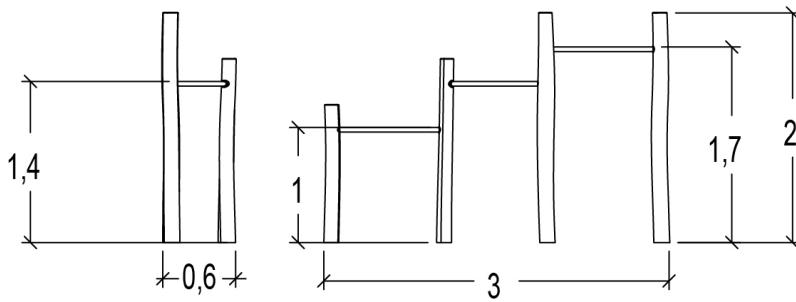

## ▶ Sports activities : 3

hanging



muscle strengthening

heart health

balance

coordination

### ► Components

#### ① Horizontal bars

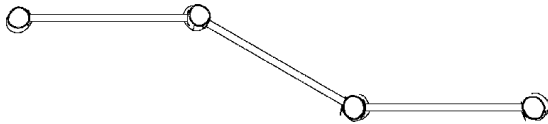

### ► Installation of equipment

**IMPORTANT:** It is essential to refer to the installation instructions for information on the size of the safety areas.

**————** Impact area (minimum normative surface)

**- - - -** Free space

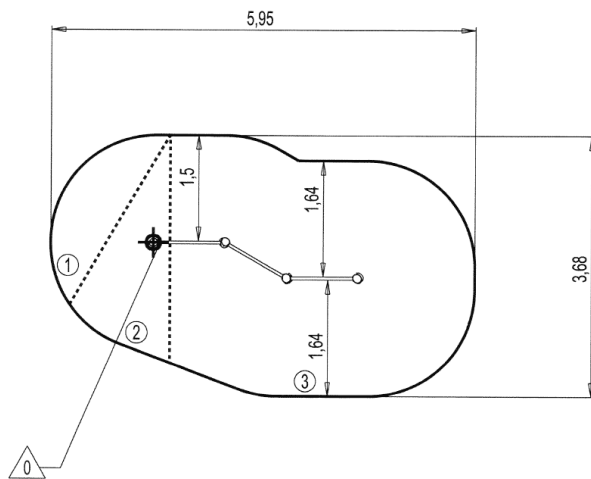

Point de Référence  
Setting Out Point  
Punto de referencia  
Bezugspunkt



1	1m	2m <sup>2</sup>
2	1,4m	2,5m <sup>2</sup>
3	1,7m	13,5m <sup>2</sup>



2



01h00



0.26m<sup>3</sup>



18m<sup>2</sup>



111kg



29kg

