

Sports formula

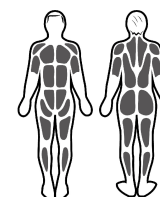

Muscular stimulation

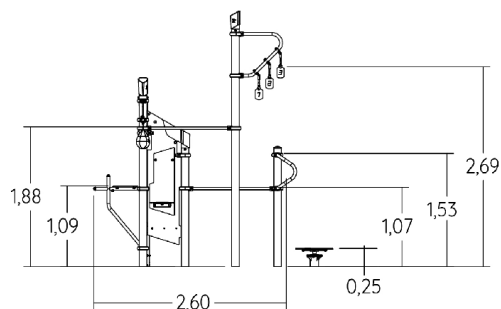
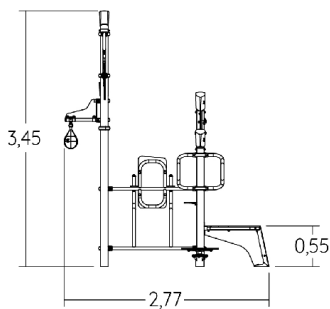

► **Sports activities :** **9**

balancing



x1

jumping



x1

hanging



x2

Pull-ups



x2

Dips



x1

Abs



x1

boxing



x1

muscle strengthening

heart health

balance

coordination

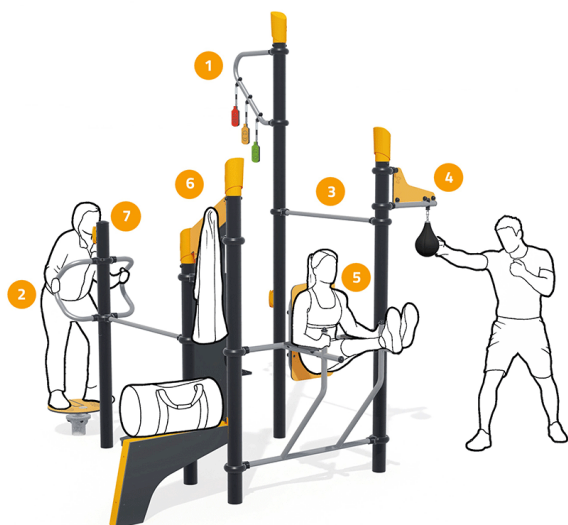

## ► Components





- ① Vertical jump activity
- ② Balance Board
- ③ Horizontal bar L. 125 cm
- ④ Punchball
- ⑤ Dual Dip Bars/Abs
- ⑥ 3 in 1 Totem
- ⑦ Smartphone holder

## ► Installation of equipment

**IMPORTANT:** It is essential to refer to the installation instructions for information on the size of the safety areas.

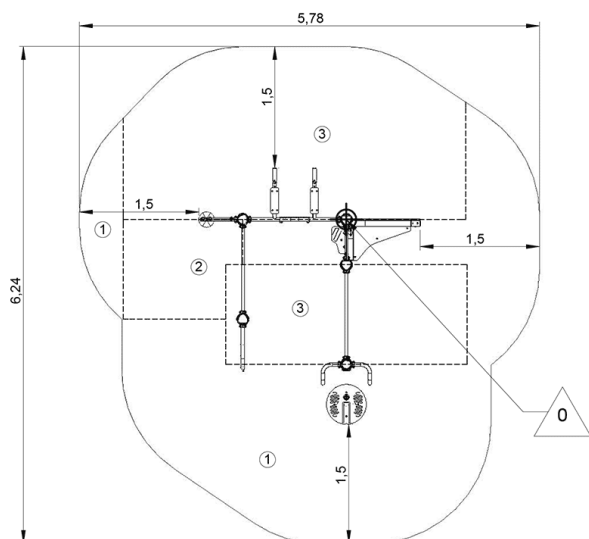
-  Impact area (minimum normative surface)
-  Free space



		
1	<0,6m	14,5m <sup>2</sup>
2	0,9m	2m <sup>2</sup>
3	1,1m	12,5m <sup>2</sup>



2



15h00



0.7m<sup>3</sup>



29m<sup>2</sup>



234kg



28kg

