



Oak

MUSKETEER™

Our **Musketeer™** Oak lectern displays have a rustic appearance and are ideal for countryside and woodland settings. Made from FSC certified hardwood Oak they offer a highly durable and aesthetically pleasing interpretation display solution.

Interpretation panels are presented at a low angle, ideal for children and wheelchair users or in areas where space is limited. Twin leg and single leg lecterns are available in a range of sizes to accommodate larger and smaller interpretation boards.

Product features

- Hardwood FSC Oak construction
- Tamper resistant fixings
- Removable graphic panel
- Easy access for children and wheelchair users
- Preservative finish
- Standard sizes A3, A2, A1 and A0
- Standard panoramic sizes 900mm x 300mm, 1200mm x 400mm and 1500mm x 500mm
- 1 year manufacturer's warranty

Specification applies to the standard product. Our range of options usually allow us to accommodate any differences you may require. Please contact us and we will be happy to support you in developing this specification to meet your requirements.

Option delete/ update as appropriate

Manufacturer: Fitzpatrick Woolmer,
Unit 7 Lakeside Park, Neptune Close,
Rochester, Kent, ME2 4LT.
Tel: 01634 711 771
Email: info@fwdp.co.uk

Timber: FSC Prime Grade to BS EN 975-1

Species: Oak and Eucalyptus (external grade plywood)

Origin: France and China

Moisture content on delivery: 10% - 20%

Certification: FSC chain of custody

Finish: Sadolin Classic wood preservative, solvent based, matt

Colour: Light Oak

Visible fixings: Stainless steel security fixings to removable parts

Capacity: Will accommodate a 3mm thick printed graphic panel

Weight: 40kg

Installation: Posts extend 500mm below ground level

Guarantee: One year manufacturer's warranty

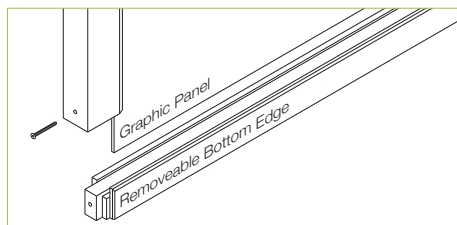

Standard frame assembly

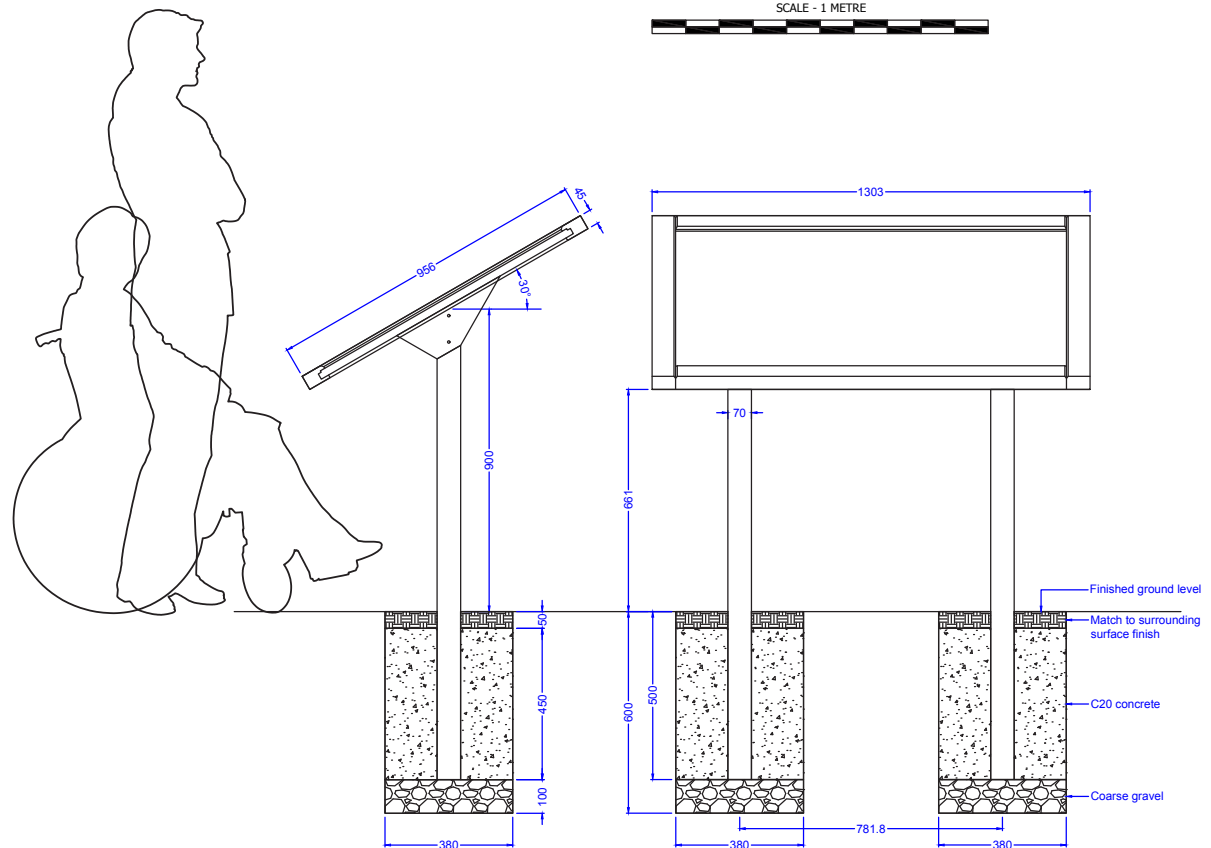

Note:
All dimensions are indicative only.
Footing details are subject to
soil conditions and structural
engineers recommendations.

Specification applies to the standard product. Our range of options usually allow us to accommodate any differences you may require. Please contact us and we will be happy to support you in developing this specification to meet your requirements.

Option delete/ update as appropriate

Manufacturer: Fitzpatrick Woolmer,
Unit 7 Lakeside Park, Neptune Close,
Rochester, Kent, ME2 4LT.
Tel: 01634 711 771
Email: info@fwdp.co.uk

Timber: FSC Prime Grade to BS EN 975-1

Species: Oak and Eucalyptus (external grade plywood)

Origin: France and China

Moisture content on delivery: 10% - 20%

Certification: FSC chain of custody

Finish: Sadolin Classic wood preservative, solvent based, matt

Colour: Light Oak

Visible fixings: Stainless steel security fixings to removable parts

Capacity: Will accommodate a 3mm thick printed graphic panel

Weight: 29kg

Installation: Posts extend 500mm below ground level

Guarantee: One year manufacturer's warranty

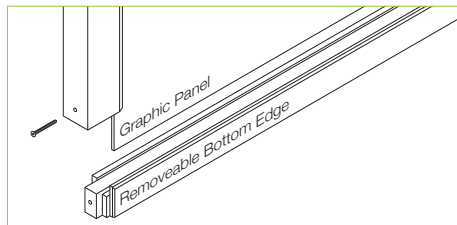

Standard frame assembly

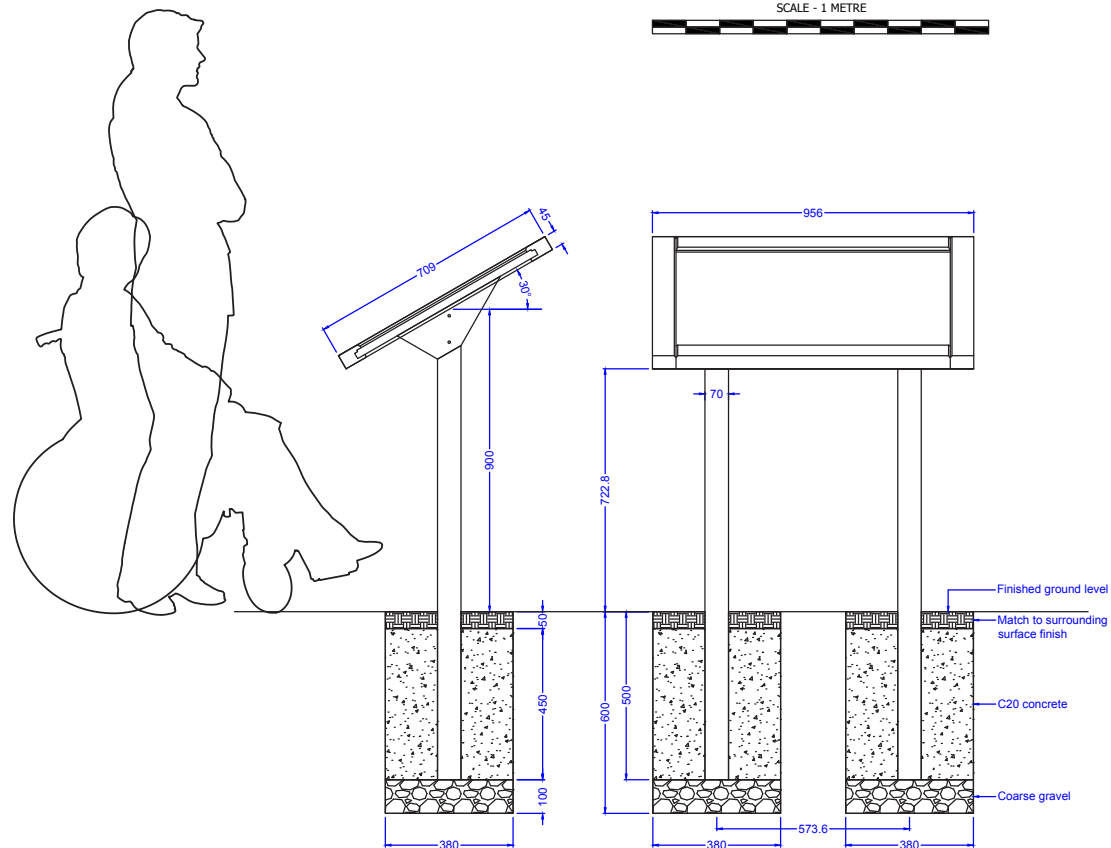

Note:
All dimensions are indicative only.
Footing details are subject to
soil conditions and structural
engineers recommendations.

Specification applies to the standard product. Our range of options usually allow us to accommodate any differences you may require. Please contact us and we will be happy to support you in developing this specification to meet your requirements.

Option delete/ update as appropriate

Manufacturer: Fitzpatrick Woolmer,
Unit 7 Lakeside Park, Neptune Close,
Rochester, Kent, ME2 4LT.
Tel: 01634 711 771
Email: info@fwdp.co.uk

Timber: FSC Prime Grade to BS EN 975-1

Species: Oak and Eucalyptus (external grade plywood)

Origin: France and China

Moisture content on delivery: 10% - 20%

Certification: FSC chain of custody

Finish: Sadolin Classic wood preservative, solvent based, matt

Colour: Light Oak

Visible fixings: Stainless steel security fixings to removable parts

Capacity: Will accommodate a 3mm thick printed graphic panel

Weight: 23kg

Installation: Posts extend 500mm below ground level

Guarantee: One year manufacturer's warranty

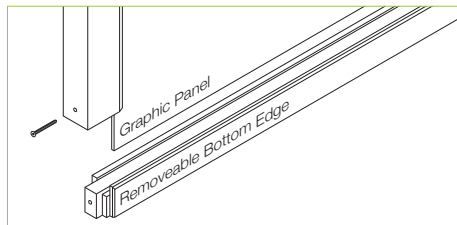

Standard frame assembly

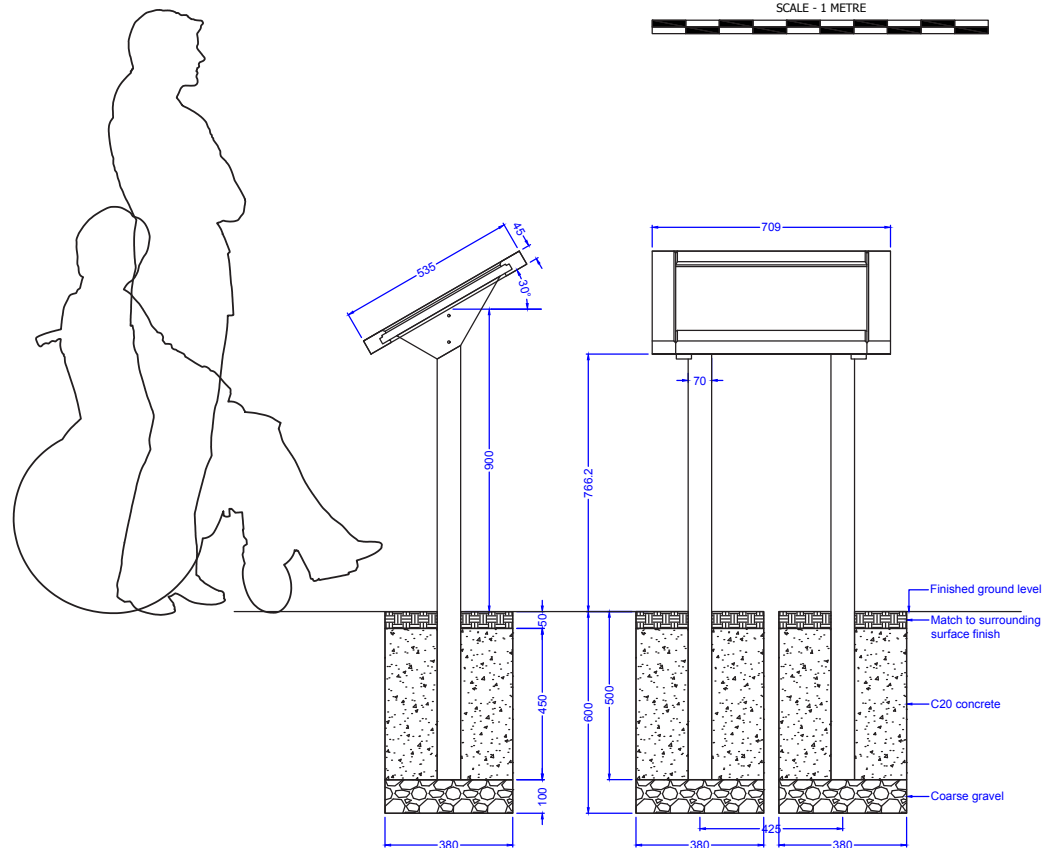

Note:
All dimensions are indicative only.
Footing details are subject to
soil conditions and structural
engineers recommendations.

Specification applies to the standard product. Our range of options usually allow us to accommodate any differences you may require. Please contact us and we will be happy to support you in developing this specification to meet your requirements.

Option delete/ update as appropriate

Manufacturer: Fitzpatrick Woolmer,
Unit 7 Lakeside Park, Neptune Close,
Rochester, Kent, ME2 4LT.
Tel: 01634 711 771
Email: info@fwdp.co.uk

Timber: FSC Prime Grade to BS EN 975-1

Species: Oak and Eucalyptus (external grade plywood)

Origin: France and China

Moisture content on delivery: 10% - 20%

Certification: FSC chain of custody

Finish: Sadolin Classic wood preservative, solvent based, matt

Colour: Light Oak

Visible fixings: Stainless steel security fixings to removable parts

Capacity: Will accommodate a 3mm thick printed graphic panel

Weight: 18kg

Installation: Post extends 500mm below ground level

Guarantee: One year manufacturer's warranty

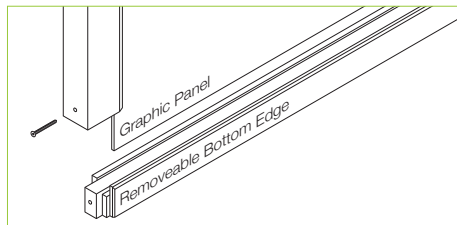

Standard frame assembly

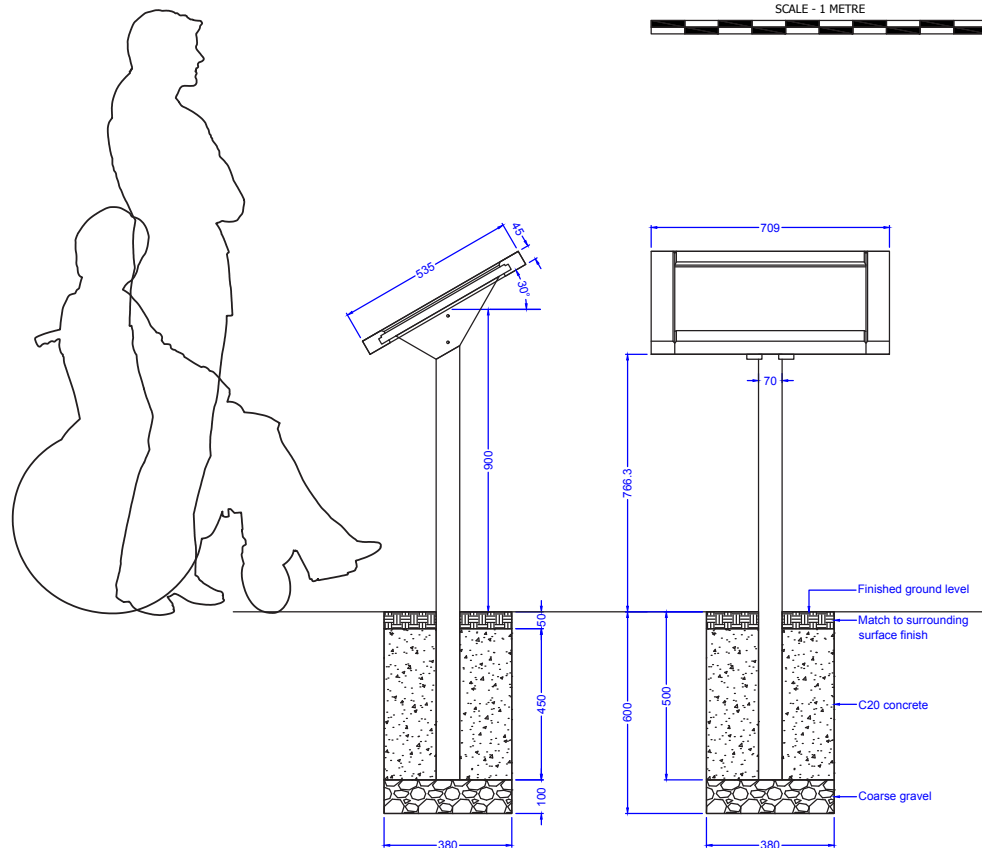

Note:
All dimensions are indicative only.
Footing details are subject to
soil conditions and structural
engineers recommendations.

Specification applies to the standard product. Our range of options usually allow us to accommodate any differences you may require. Please contact us and we will be happy to support you in developing this specification to meet your requirements.

Option delete/ update as appropriate

Manufacturer: Fitzpatrick Woolmer, Unit 7 Lakeside Park, Neptune Close, Rochester, Kent, ME2 4LT.
Tel: 01634 711 771
Email: info@fwdp.co.uk

Timber: FSC Prime Grade to BS EN 975-1

Species: Oak and Eucalyptus (external grade plywood)

Origin: France and China

Moisture content on delivery: 10% - 20%

Certification: FSC chain of custody

Finish: Sadolin Classic wood preservative, solvent based, matt

Colour: Light Oak

Visible fixings: Stainless steel security fixings to removable parts

Capacity: Will accommodate a 3mm thick printed graphic panel

Weight: 16kg

Installation: Post extends 500mm below ground level

Guarantee: One year manufacturer's warranty

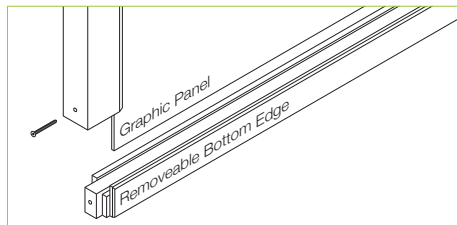

Standard frame assembly

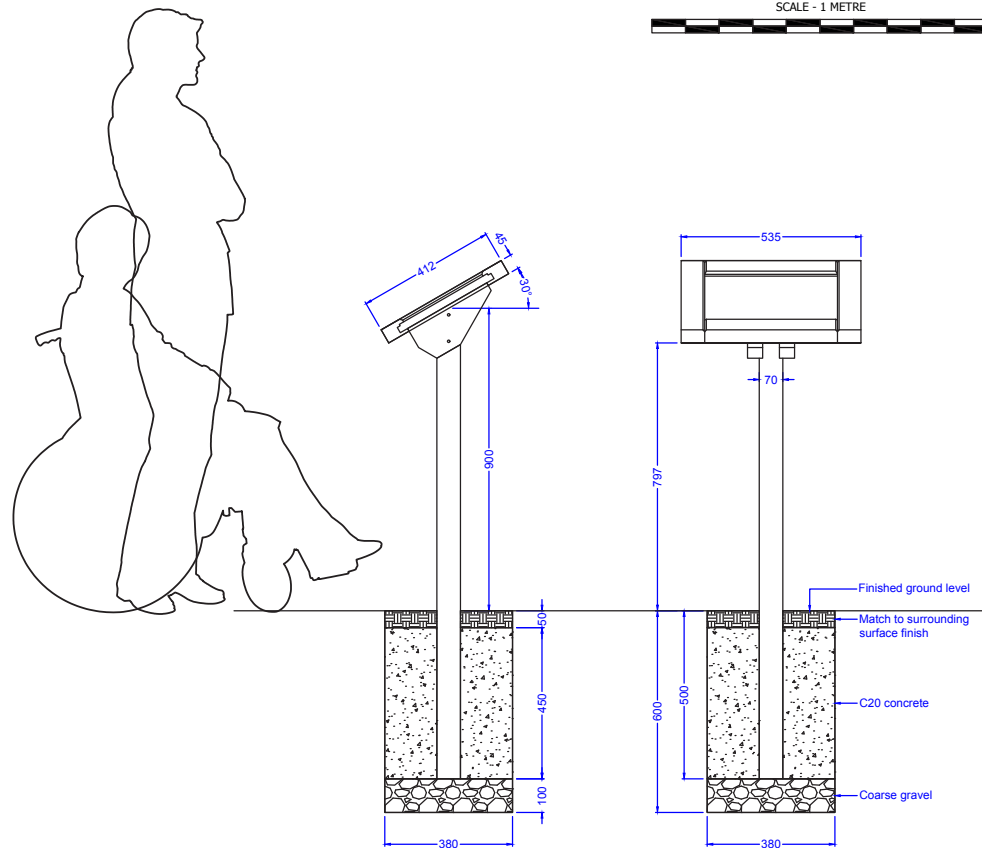

Note:
All dimensions are indicative only. Footing details are subject to soil conditions and structural engineers recommendations.

Specification applies to the standard product.
 Our range of options usually allow us to accommodate any differences you may require.
 Please contact us and we will be happy to support you in developing this specification to meet your requirements.

Option delete/ update as appropriate

Manufacturer: Fitzpatrick Woolmer,
 Unit 7 Lakeside Park, Neptune Close,
 Rochester, Kent, ME2 4LT.
Tel: 01634 711 771
Email: info@fwdp.co.uk

Timber: FSC Prime Grade to BS EN 975-1

Species: Oak and Eucalyptus (external grade plywood)

Origin: France and China

Moisture content on delivery: 10% - 20%

Certification: FSC chain of custody

Finish: Sadolin Classic wood preservative,
 solvent based, matt

Colour: Light Oak

Visible fixings: Stainless steel security fixings to removable parts

Capacity: Will accommodate a 3mm thick printed graphic panel

Weight: 23kg

Installation: Posts extend 500mm below ground level

Guarantee: One year manufacturer's warranty

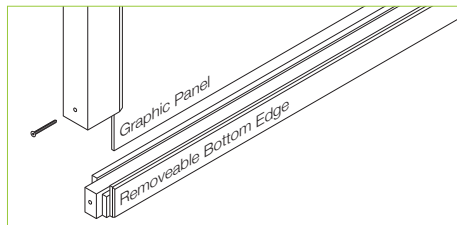

Standard frame assembly

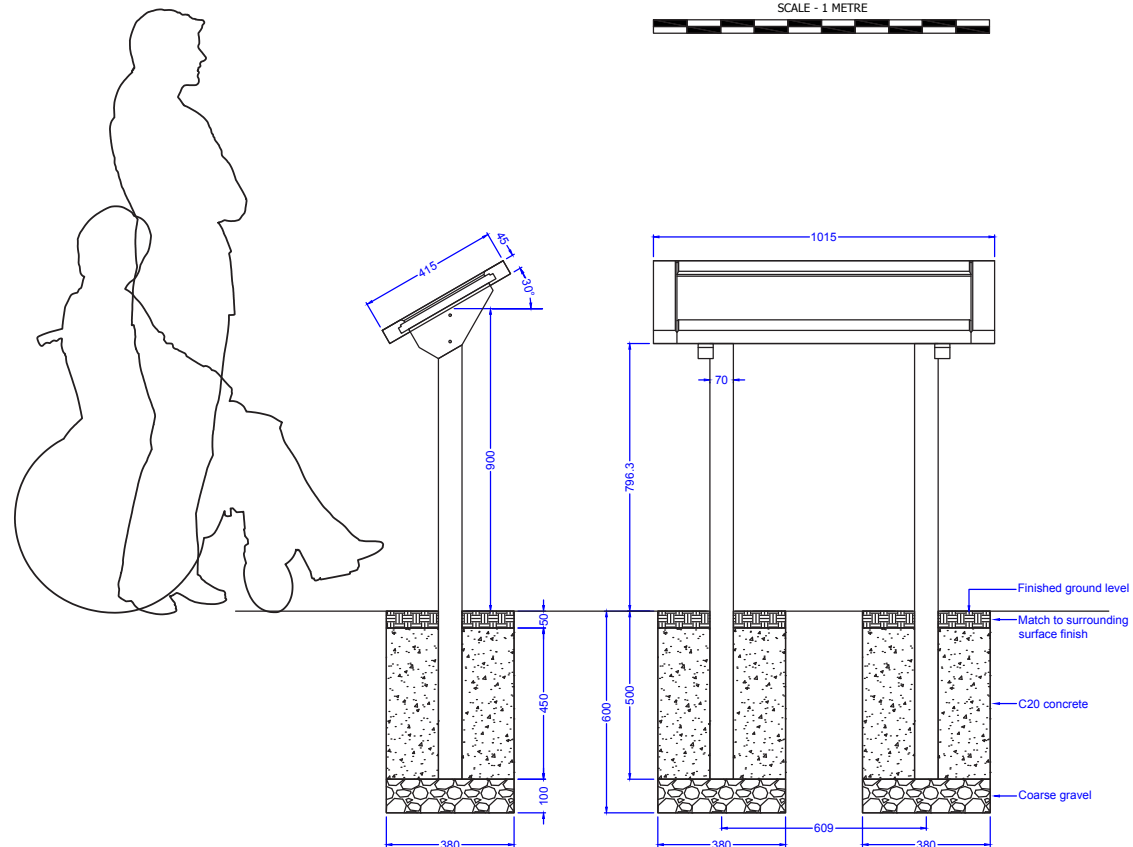

Note:
 All dimensions are indicative only.
 Footing details are subject to
 soil conditions and structural
 engineers recommendations.

Specification applies to the standard product. Our range of options usually allow us to accommodate any differences you may require. Please contact us and we will be happy to support you in developing this specification to meet your requirements.

Option delete/ update as appropriate

Manufacturer: Fitzpatrick Woolmer,
Unit 7 Lakeside Park, Neptune Close,
Rochester, Kent, ME2 4LT.
Tel: 01634 711 771
Email: info@fwdp.co.uk

Timber: FSC Prime Grade to BS EN 975-1

Species: Oak and Eucalyptus (external grade plywood)

Origin: France and China

Moisture content on delivery: 10% - 20%

Certification: FSC chain of custody

Finish: Sadolin Classic wood preservative, solvent based, matt

Colour: Light Oak

Visible fixings: Stainless steel security fixings to removable parts

Capacity: Will accommodate a 3mm thick printed graphic panel

Weight: 28kg

Installation: Posts extend 500mm below ground level

Guarantee: One year manufacturer's warranty

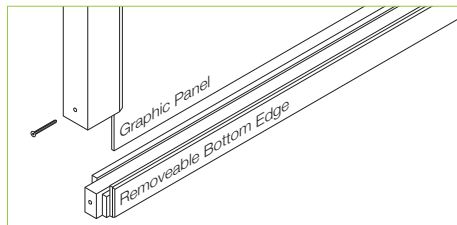

Standard frame assembly

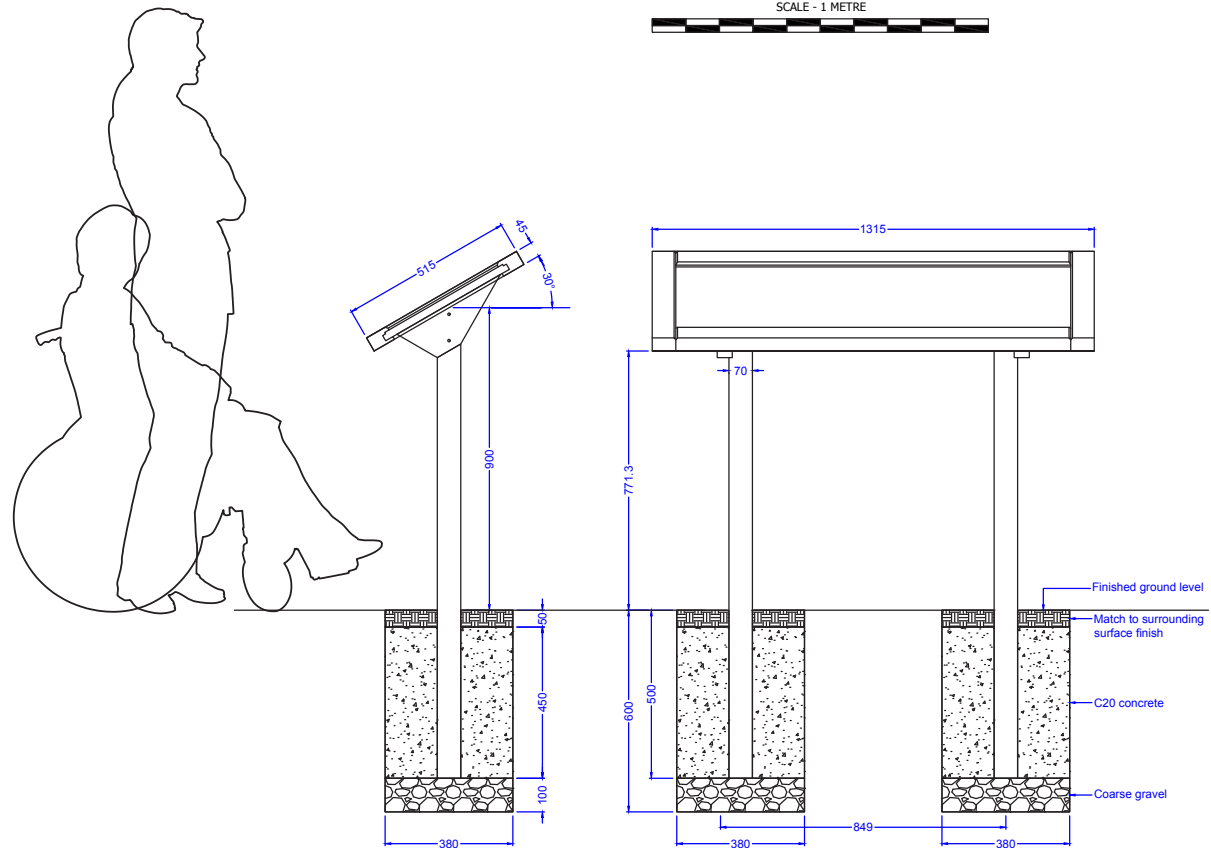

Note:
All dimensions are indicative only.
Footing details are subject to
soil conditions and structural
engineers recommendations.

Specification applies to the standard product. Our range of options usually allow us to accommodate any differences you may require. Please contact us and we will be happy to support you in developing this specification to meet your requirements.

Option delete/ update as appropriate

Manufacturer: Fitzpatrick Woolmer,
Unit 7 Lakeside Park, Neptune Close,
Rochester, Kent, ME2 4LT.
Tel: 01634 711 771
Email: info@fwdp.co.uk

Timber: FSC Prime Grade to BS EN 975-1

Species: Oak and Eucalyptus (external grade plywood)

Origin: France and China

Moisture content on delivery: 10% - 20%

Certification: FSC chain of custody

Finish: Sadolin Classic wood preservative, solvent based, matt

Colour: Light Oak

Visible fixings: Stainless steel security fixings to removable parts

Capacity: Will accommodate a 3mm thick printed graphic panel

Weight: 34kg

Installation: Posts extend 500mm below ground level

Guarantee: One year manufacturer's warranty

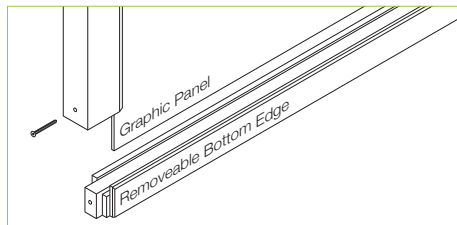

Standard frame assembly

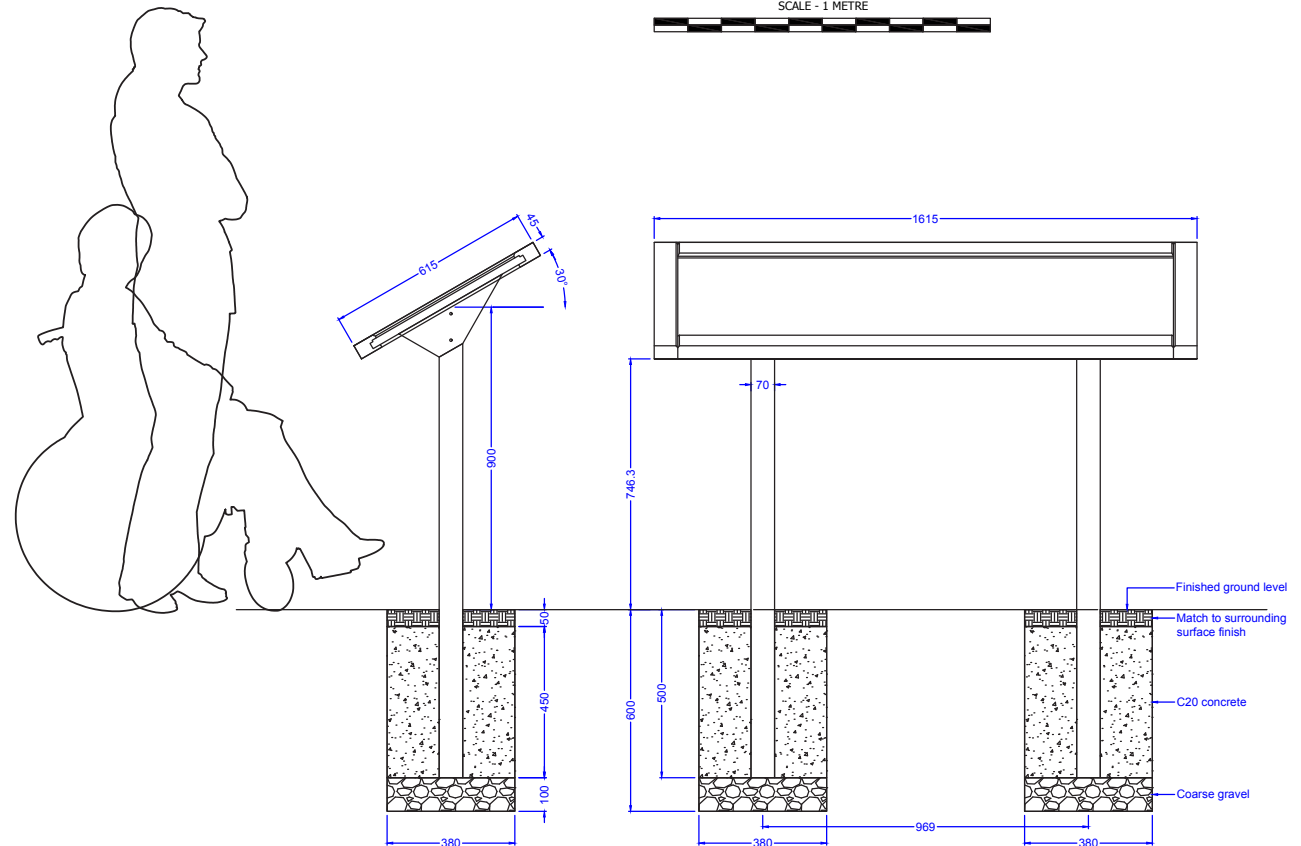

Note:
All dimensions are indicative only.
Footing details are subject to
soil conditions and structural
engineers recommendations.