



OMOS

v55  
Stool



[www.omos.ie](http://www.omos.ie)  
+ 353 45 899 802

# v55 Stool



**DESCRIPTION**

Solid green oak beam supported on Corten steel feet. Available with or without back and armrest. Co-ordinating bench and seat.

**DIMENSIONS**

Width 450mm, Depth 450mm, Height 450mm.

**OPTIONS**

Choice of fixing; AGFF or BGFF.

Constructed from green oak timber and weathering steel, the v55 is rugged and eye-catching. These materials change and evolve over time adding a strong sense of nature to any environment.

Weathering steel exhibits remarkable corrosion resistance and an ability to heal when damaged. Green oak timber's innate strength, weather resistance and charming aging process make it a sustainable and timeless option for outdoors.

The v55 is designed to be bolt fixed to a foundation either above or below ground.

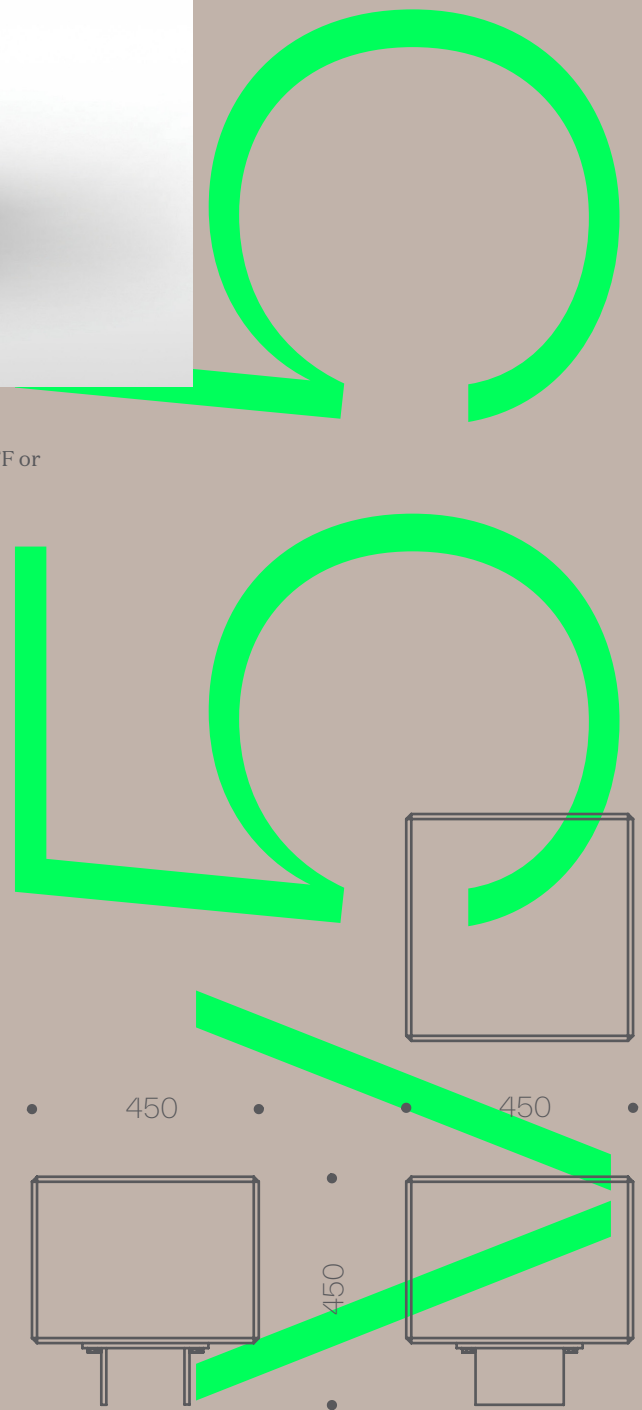

www.omos.ie  
+ 353 45 899 802

# v55 Stool Fixing Instructions

## ABOVE GROUND FLANGE FIXED

### FOR AREAS ALREADY PAVED

1. Determine the location for the stool. Remove the pavers and excavate a hole to minimum dimensions of L600 x W600 x D400mm. The size of the foundations may vary depending on the ground conditions.
2. Fill the holes with 35N20 concrete up to 15mm below the level of the underside of the pavers ensuring a good smooth surface finish.
3. Allow sufficient time for the concrete to set then apply a layer of dry sand/cement mix over the pad. Compact and adjust to bring this to the level of the underside of the paving.
4. Replace the paving slabs and ensure that they are well bedded in.
5. Place the stool in the desired location and mark through the fixing holes making sure this is done accurately.
6. Remove the stool and drill through the paving slabs into the concrete pad below. Drill following fixing manufacturer's instructions to suit the chosen fixing. Choose a fixing which will accept an M12 SS hex head bolt/set screw, either a mechanical anchor (such as Hilti HKD-SR SS316 M12 DROP-IN ANCHOR) or an internally threaded fixing designed for chemical fixing (such as Hilti HIS-RN M12xL [length to suit]). IMPORTANT, the depth of the hole must be sufficient to allow the fixing to be fully embedded in the concrete rather than partially in the paver and partially in the concrete.
7. Insert the fixings into the ground following fixing manufacturer's instructions. Reposition the stool and screw in M12 SS hex bolt/set screw into the 4 no. fixings. Where chemical fixing is used (such as Hilti HIT-HY 150) leave sufficient time to cure before. Tighten the bolts.

### FOUNDATIONS

The v55 stool can be fixed directly to a concrete slab or to concrete pads beneath paving stones. Foundations must be to engineer's specification.

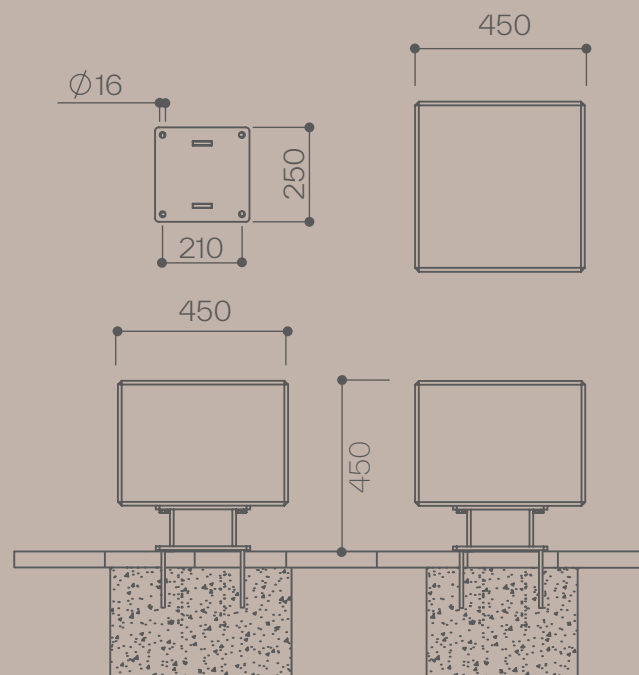

# v55 Stool Fixing Instructions

## BELOW GROUND FLANGE FIXED

### FOR AREAS ALREADY PAVED

1. Determine the location for the stool. Remove the pavers and excavate one hole to minimum dimensions of L600 x W600 x D400mm. The size of the foundations may vary depending on the ground conditions.
2. Fill the holes with 35N20 concrete up to 135mm below finished paving level ensuring the pads are level relative to each other (if the paving is not level then aim to achieve an average of 135mm). The pads should be floated smooth.
3. Allow sufficient time for the concrete to set.
4. Place the stool in the desired location and mark through the fixing holes making sure this is done accurately.
5. Remove the stool and drill into the concrete pad. Drill following fixing manufacturer's instructions to suit the chosen fixing. Use M12 through bolts to fix (such as Hilti HSA M12 x 120).
6. Insert the fixings into the ground following fixing manufacturer's instructions then reposition the stool. Screw on and tighten the nuts.
7. Where necessary cut the paving slabs and reinstated ensuring that they are well bedded in.
8. Render neatly around leg tubes with non shrink grout, removing any grout residue.

### FOUNDATIONS

Foundations must be to engineer's specification.

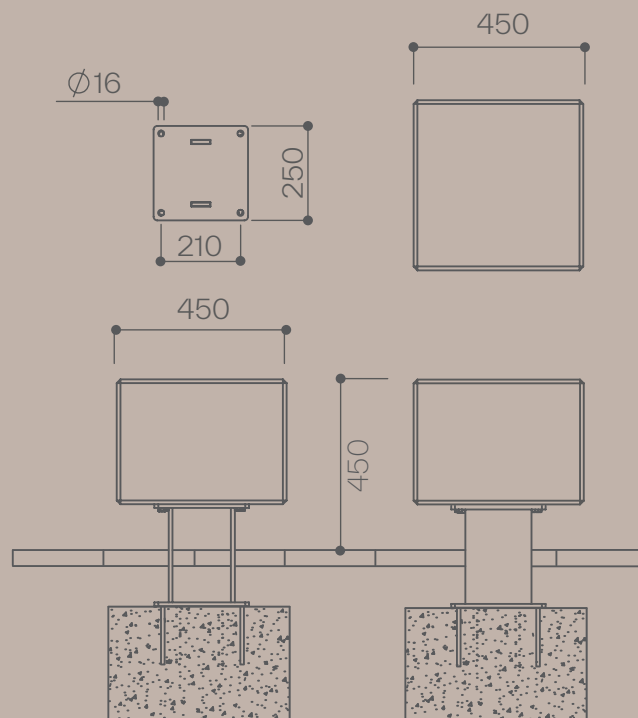

# Maintaining Green Oak Timber

## GREEN OAK TIMBER

Green oak is often chosen for outdoor furniture due to its extremely durable properties and distinctive natural character. The beauty of its organic form includes cracks, knots and cavities in the timber. When the timber is cut initially it has a blond or golden brown hue. Although the timber will stay structurally sound for years, over time the sunlight and weather exposure will cause the colour to change to silver or dark grey. As well as changing colour, natural cracks and cavities will emerge and those already present will expand. Follow the instructions below to address these evolving changes. Omos applies two coats of clear wood preservative to the freshly planed and sanded oak. This finish does not alter the appearance of the timber.



## MAINTENANCE

### 1. SANDING

It is important to inspect your timber regularly and any splinters should be removed and sharp edges rounded using an 80-120 grit sanding block.

### 2. SANDING EDGES

Where cracks have emerged close to the edge leaving a fragile shard, we recommend it is removed and the remaining area is sanded and smoothed.

### 3. TREATING

Mould and algae can be removed using a biocide treatment. Always adhere to the products instructions for use and safety precautions.

# Weathering Steel



## WEATHERING STEEL

Weathering Steel, also known as Corten (the original brand name), is an extremely durable material, which makes it suitable for many street furniture applications. Before choosing Weathering Steel, it's important to consider a potential downside: the pigmented runoff from the material. Until Weathering Steel fully stabilizes, this runoff may stain the ground beneath or transfer onto anything it comes into contact with, such as clothing.

Mitigation measures can be taken, such as gravel borders, or grating around objects. Sealers can be used where contact is likely, but they do detract from the natural look of the material and, unlike exposed Weathering Steel, do require maintenance.

# Maintaining Weathering Steel



## MAINTENANCE

Prior to shipping, all our weathering steel has been shot blasted to remove mill scale and give the surface an even finish. Once the material has been shot blasted, it has a grey metallic appearance but will quickly start to oxidize and turn orangey-brown, which darkens over time.

There may be some unevenness in the finish initially, as the initial formation of the passive layer sees a very distinctive change in colour over a short period of time. Any unevenness will disappear within a number of months. The patination process can be accelerated by the use of chemicals, but the simplest and safest way to speed up the process is by spraying the material with a saltwater solution over a period of a couple of weeks.

Should the Corten require cleaning this can be done using a scrubbing brush and warm water with a mild detergent. Avoid abrasive cleaners as they will remove or alter the texture of the weathered surface. Graffiti can be removed using a graffiti remover such as AF Graffiti Remover Gel GRG400.