



OMIOS

v61
Planter



www.omos.ie
+ 353 45 899 802

v61 Planter



DESCRIPTION

Tapering planter box in 316 grade stainless steel with powder coated finish. Cantilever bench to two adjacent sides. Recess to base to facilitate fork lift / pallet truck access.

DIMENSIONS

Width /Depth 1600mm (1000mm/865mm Inside), Height 1000mm (Seat Height 450mm).

OPTIONS

Choice of RAL colours for powder coating. Hardwood or RHS 316 grade stainless steel bench. Unfinished hardwood or microporous coating.

Constructed from stainless steel with a powder coated finish, the v61 combines durability with aesthetics.

The reverse tapered form offers a comfortable backrest to the bench while the recessed faces provide forklift access for lifting when planted.

The two sided hardwood bench is discretely fixed to the planter by means of reinforced stainless steel pipes and sleeves running through the timber.

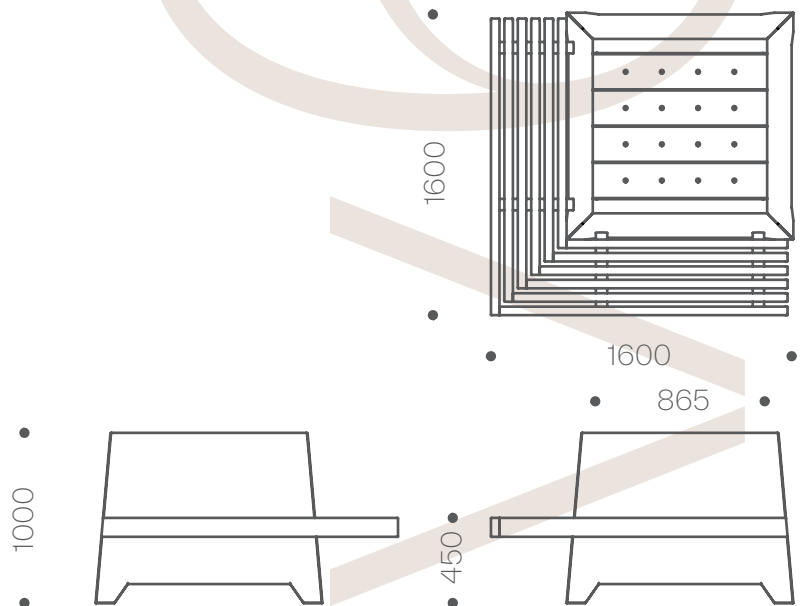

Maintaining Powder Coating



MAINTENANCE

Polyester powder coating is a dry finishing process where a polyester resin powder is applied to a metallic surface and then oven-baked. This creates a durable, protective finish that resists corrosion, weathering, and UV damage. Its versatility allows for a wide range of colour choices, ensuring vibrant and long-lasting aesthetics for diverse applications.

Despite its durability, some care is required to maintain the appearance of the material. The extent to which maintenance is required depends on a number of factors. These include environmental conditions, construction activity and level of use.

To maintain the original appearance of the metalwork, it should be cleaned regularly using warm soapy water. Avoid the use of abrasive cleaners as they may damage the surface finish.

Should the coating become chipped or scratched, it can be touched up using a colour matching metal paint. Where the surface becomes damaged clean with a wire brush or sandpaper, then paint with an outdoor metal paint. Omos recommends Uni 2k paint which can be purchased from most industrial or automotive paint suppliers. We recommend testing on a hidden area to ensure a good colour match before applying to the damaged region. For further advice contact Omos.

Hardwood Finishes



MICROPOROUS COATED

The board in the top half of the image is iroko hardwood with a factory applied microporous stain. This finish offers very good resistance to UV rays as well as enriching and enhancing the hardwood's rich colour. Provided the coating surface does not become broken, the colour will not fade for several years. The microporous coating is however vulnerable to conditions where high moisture and severe cold persists. Conditions as these such can cause the coating to blister and lift.

UNTREATED

The board in the bottom half of the image is iroko hardwood that has been freshly sanded and left untreated. When left untreated, the hardwood begins to fade within weeks of exposure to sunlight. After some time, the timber begins to change to a silver-grey achromatic colour. Despite the difference in appearance, the timber remains structurally sound due to its inherent durability.

Maintaining Microporous Coated Hardwood



MAINTENANCE

Microporous coated hardwood should be cleaned regularly using mild detergents. After some time, maintenance of the finish is required. To determine the necessary course of action, first assess the condition of the coating and follow the instructions below. We have chosen the three most common conditions that may occur with microporous coatings.

1. COATING HAS FADED EVENLY BUT HAS NOT BLISTERED OR FLAKED.

Clean the hardwood thoroughly with soapy water and a scouring pad. Lightly sand the surface. If the coating flakes or is easily removed by sanding, follow the steps detailed for instructions 2 or 3. Apply Sikkens Cetol Filter 7 Plus using a brush. Always follow the coating manufacturer's instructions carefully.

2. COATING HAS BLISTERED OR FLAKED BUT IN SMALL PATCHES ONLY (2-3 SQ CM).

Where small areas have blistered, this area should be sanded back locally to bare hardwood. Apply Sikkens Cetol Filter 7 Plus, colour 085 Teak to the sanded area only. Once dry, lightly sand all the timber and apply two coats of Sikkens Cetol Filter 7 Plus across the entire timber surface. Always follow the coating manufacturer's instructions carefully.

3. COATING HAS BLISTERED OR FLAKED ACROSS LARGE AREAS.

Where large areas have blistered or flaked, that damaged face should be sanded back to bare hardwood. Apply two or three coats of Sikkens Cetol Filter 7. Always follow the coating manufacturer's instructions carefully.

Timber is a natural product therefore warping and cracking can occur. It is important to inspect your timber regularly. Whenever cracks appear they should be sanded to eliminate any sharp edges. Splinters should be pared away or sanded. If the function, structure, performance or safety of the product is affected, the piece of timber should be replaced.

Maintaining Unfinished Hardwood



MAINTENANCE

Iroko is an extremely durable hardwood and does not require a protective coating to preserve its structural properties. Without maintenance timber will turn grey, as seen in the left-hand side of image above. To help preserve the colour, you may apply an oil such as tung oil or linseed oil, or use a microporous coating. Timber is a natural product therefore warping and cracking can occur. It is important to inspect your timber regularly. Whenever cracks appear they should be sanded to eliminate any sharp edges. Splinters should be pared away or sanded. If the function, structure, performance or safety of the product is affected, the piece of timber should be replaced.

Cleaning can be done using a number of methods. For regular cleaning use a scrubbing brush or scouring pad with warm water and a mild detergent. Take care to avoid contact with any metal or painted surfaces on the product when using an abrasive method of cleaning. Timber that has been left for some time unmaintained can be restored using a wood cleaner/restorer product such as Owatrol Net-trol Wood Cleaner and Brightener. Such products are widely available, when applying follow the product's user instructions carefully.

The timber can be brought back to its natural colour by sanding. Start with a coarse sanding block (60 grit) and work up through the grades to finish with 120 grit.

Stainless Steel Finishes

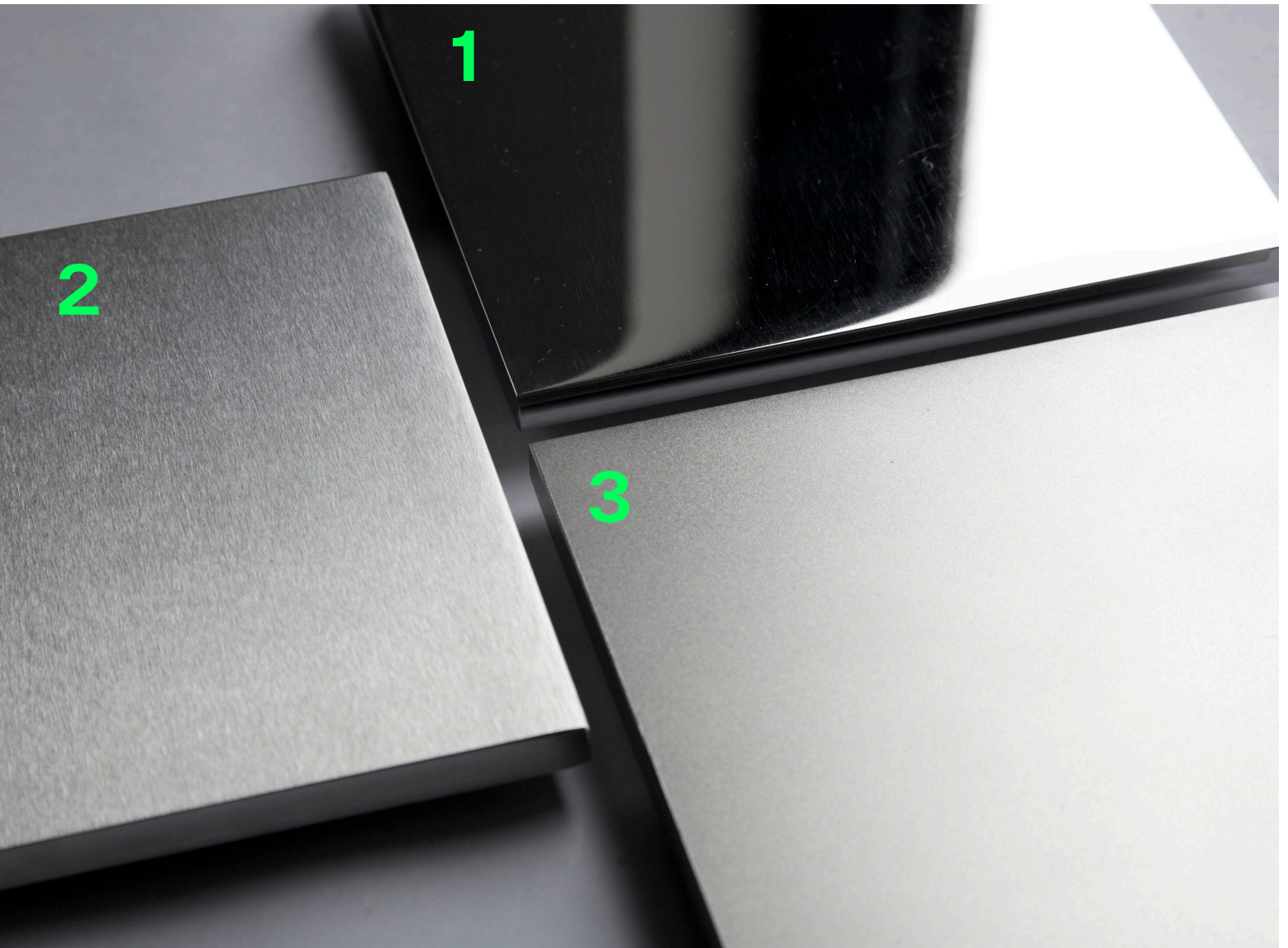

316 GRADE STAINLESS STEEL

1. MIRROR POLISHED

Stainless steel with a mirror polished finish undergoes a process that results in a smooth and highly reflective surface. This finish offers a shiny, mirror-like appearance, enhancing the steel's aesthetic appeal.

2. BRUSHED POLISH

Stainless steel with a brushed polish finish undergoes a process involving abrasive belts which create fine parallel lines on the surface, giving it a muted sheen and a directional texture.

3. BEAD BLASTED

Stainless steel with a bead blasted finish is textured using abrasive glass beads, resulting in a non-reflective, matte surface. This finish provides a uniform appearance with a soft texture while maintaining the steel's corrosion resistance.

Maintaining Stainless Steel

Prior to shipping, our stainless steel has been passivated to ASTM A380 and ASTM 976 01-8.1 to ensure the highest standard. Rust spots or 'tea stains' can occur on the surface, these are normally caused by contamination from carbon steel, particularly in areas where construction work has been undertaken. Such stains can be removed using a non-abrasive rust remover such as RC Disox supplied by Abcon Industrial Products Ltd. Follow chemical manufacturers' health and safety instructions and take extreme care to protect any other surfaces from exposure to the chemical.

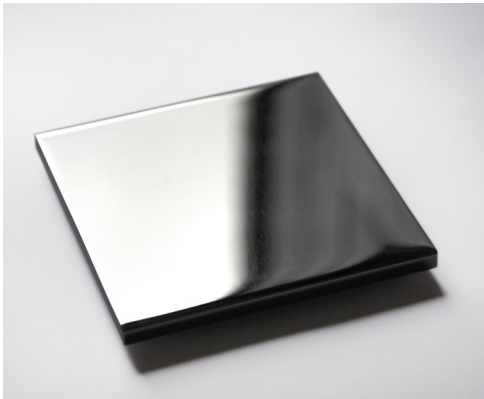

MIRROR POLISHED STAINLESS STEEL

To clean mirror polished stainless steel, use only a non-abrasive sponge or cloth as abrasive materials will damage the mirror-like appearance of the finish. The material should be cleaned using mild detergents and warm water.

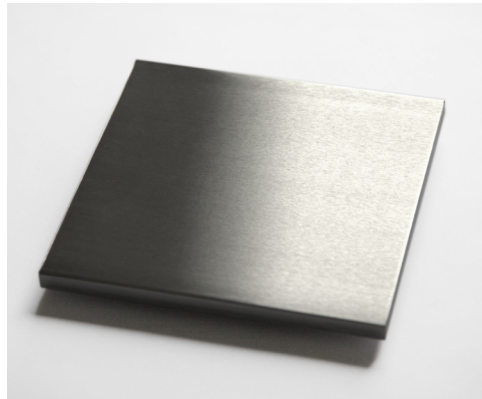

BRUSH POLISHED STAINLESS STEEL

To clean brush polished stainless steel, a non abrasive cloth or sponge used with warm water and mild detergent is recommended. If abrasive cleaning is required, use an abrasive fibre pad (such as Scotch-Brite™), not wire wool. Use a straight back-forward rubbing action parallel to the grain in the material.

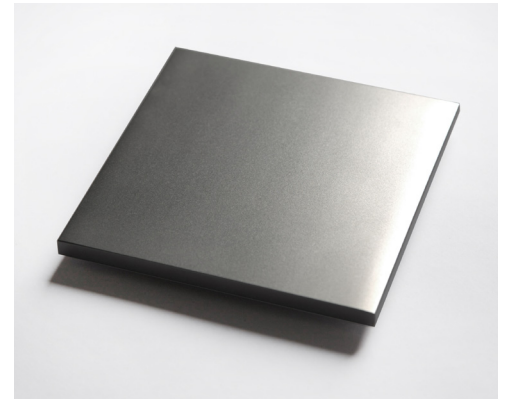

BEAD BLASTED STAINLESS STEEL

To clean bead blasted stainless steel, a non abrasive cloth or sponge used with warm water and mild detergent is recommended. If abrasive cleaning is required, use an abrasive fibre pad (such as Scotch-Brite™), not wire wool. Use random circular rubbing actions when cleaning the material.