



HEALD®

PRODUCT BROCHURE

ISSUE 11

DESIGNERS, MANUFACTURERS AND INSTALLERS OF
AWARD-WINNING PERIMETER SECURITY PRODUCTS

World-Leading Security Bollards, Roadblockers and Barriers



CONTENTS

About Heald Heald Service	04-05 06-07
Introduction To HVM	08-09
Matador Raptor EVO	10-21 22-23 24-25
Mantis APEX Synergy Bollard System Sparta Bollards AutoBollards	26-27 28-31 32-33 34-35 36-37
Connecting Product	38-39
Viper Commander PAS 68 Roadblockers	40-41 42 43
Traffic Control Products	44-45
Hydra Access Control System	46-47
Installation, Maintenance & Servicing	48-49
Distribution	50-51

About Heald

For over three decades, Heald has been trusted to secure some of the world's most high-profile locations with advanced protection against hostile vehicle attacks.

Our global client base includes military sites, presidential buildings, palaces, embassies, border controls, airports, oil refineries, stadia, banks, data centres, shopping centres, government buildings and many more.

Our range of award-winning PAS68, IWA and ASTM Bollards, Roadblockers and Barriers play a leading role in the defence of vulnerable properties worldwide from expressive and acquisitive crime.

World class innovators of solutions for a safer world

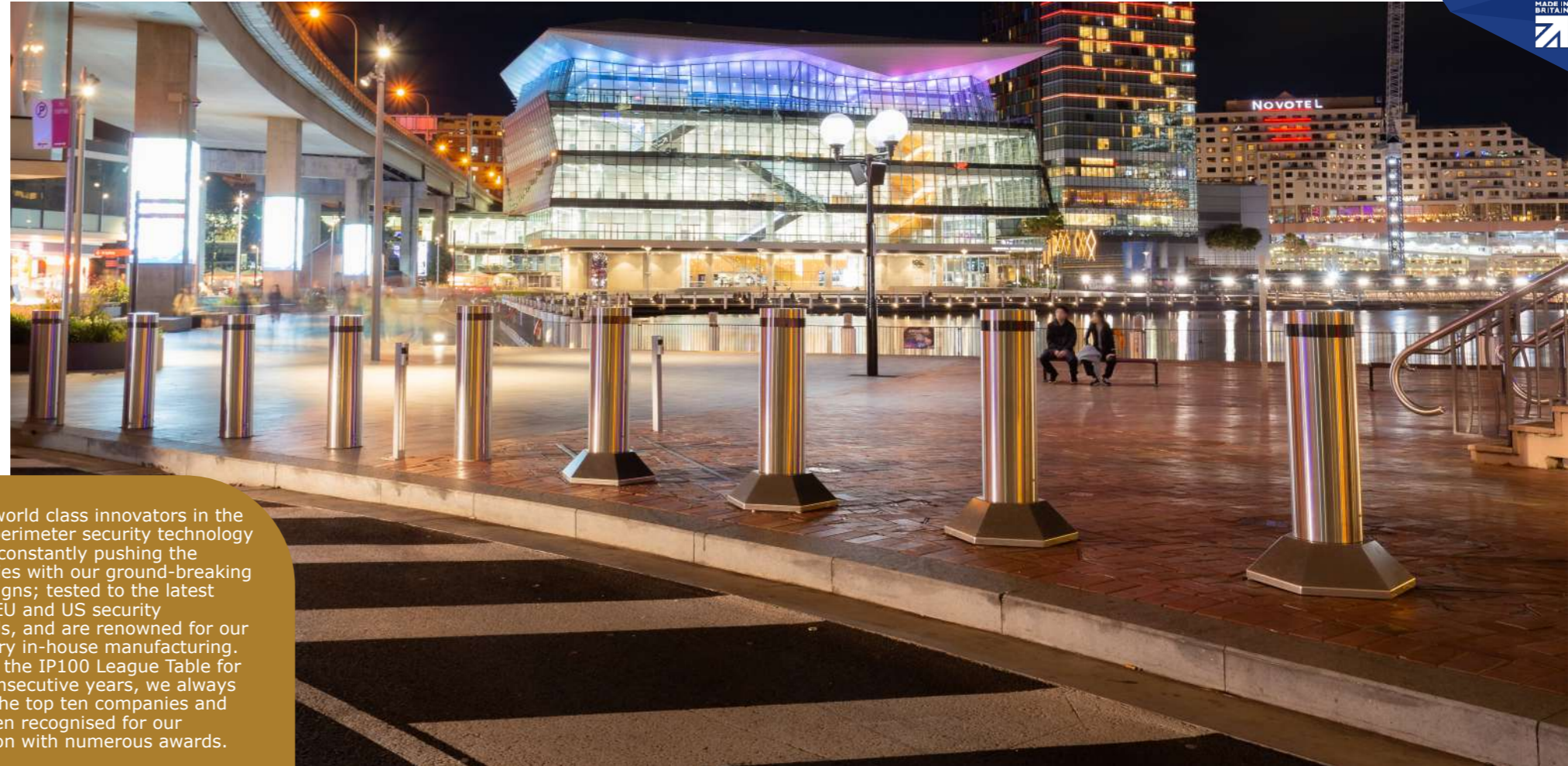

Awards & Accreditations



We are world class innovators in the field of perimeter security technology and are constantly pushing the boundaries with our ground-breaking new designs; tested to the latest British, EU and US security standards, and are renowned for our exemplary in-house manufacturing. Listed in the IP100 League Table for three consecutive years, we always rank in the top ten companies and have been recognised for our innovation with numerous awards.



Heald Service

Heald offer a full turnkey service for all of our products, from initial design to installation and maintenance.

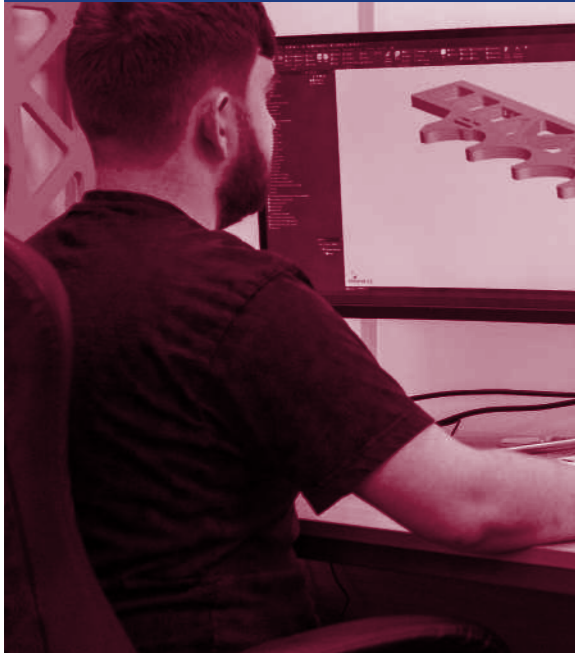

Design

Our products are designed in-house by our talented engineering department utilizing state of the art design tools and drawing upon decades of experience in the industry.



Customisation

We can offer bespoke designs to suit your site and customer specifications; ranging from different finishes, covers, sizes, configurations, engineered solutions, and operational requirements.



Manufacture

All our products are manufactured in-house by our highly skilled and experienced team.

We are fully ISO9001 registered with strict quality control at every stage ensuring the products we supply are of the highest quality.



Installation

We have a team of multi-skilled engineers and installers who are always available on site if required, throughout the UK and overseas. Heald offer a range of services from installation to on-site support & commissioning.



Maintenance

We offer a swift response and full site support for all new and existing installations, in addition to a high level of service with qualified and experienced engineers.

Hostile Vehicle Mitigation

Hostile Vehicle Mitigation (HVM) relates to the protective security measures in place that aim to reduce the risk associated with vehicle borne threats. HVM measures form a combination of security planning, traffic management and physical security barriers.

Planning HVM measures requires a site-specific security risk assessment and a Vehicle Dynamic Assessment (VDA) to ensure you have the correct level of security which will provide appropriate and proportional protection to the location.

Heald Limited specialise in physical security barriers designed to disable a vehicle in a vehicle as a weapon (VAW) attack and mitigate any damage to a property or location by creating a standoff between the protective line and the perimeter. These products include bollards, roadblockers and barriers, which can provide authorised access or prevent all vehicle access to a location.

For further advice on which products would be suitable to meet your site requirements, please contact our friendly team at sales@heald.uk.com.

At Heald our full range of Hostile Vehicle Mitigation products have undergone rigorous in-house testing and independent physical crash tests. These tests are carried out to replicate the worst-case scenario to ensure that our products provide the maximum protection.



HVM products are tested to meet various international crash test standards to prove their efficacy. These standards are ASTM, PAS 68, IWA 14, and ISO 22343 and all provide guidance and methodologies to ensure the results are standardised and can be relied upon.

After crash testing, the product is given a crash test classification based on its performance. IWA 14 has now been superseded by ISO 22343, however, crash test results from older test specifications remain valid.

It is important to note that each test standard has an accompanying installation standard which should be followed when installing HVM product, e.g. Product tested under IWA 14-1 should be installed to IWA 14-2 guidelines.

M	50	P1	
Vehicle classification: Medium duty truck of 6800kg	Impact Speed: 64km/h	Vehicle Penetration Distance: Less than 1m	

ASTM is the American crash test standard, this supersedes the previous K-ratings. These tests use the American style vehicle which has a reduced vehicle mass compared with the European truck used in the PAS68 tests.

ISO	 	PAS68 is the UK's first crash test standard, this closely relates to the IWA standard, however the vehicle classification and the datum point for the penetration distance varies.
		IWA 14-1 was created to provide a single crash test standard for all vehicle categories including the UK, European and North American vehicle types.

Fixed Bollard V / 7500[N2] / 64 / 90 : 0.0 / 0.0

Product Type / VSB: Bollard	Test Method: Vehicle	Test Vehicle Mass: 7.5 Tonne [N2] Lorry	Impact Speed: 64km/h	Vehicle Penetration Distance beyond the VDB datum line : 0.0m
			Impact Angle to Impact Face of VSB: 90 degree impact	Debris dispersion: 0.0m (Not included for IWA14.1)



Heald prove the performance of our products by conducting multiple crash tests under different standards on our products, giving our customers confidence that they will perform, regardless of the vehicular threat.

It is sometimes necessary to provide additional information which can add to this confidence in our products, particularly if the solution is bespoke or is an engineered solution. Heald work with third party RSES certified engineers to provide this unbiased information so that we can offer site-specific reports to ensure that any variations made to a product will meet the project requirements. For further details regarding these reports and the crash test standards please contact Heald directly, or visit www.heald.uk.com



Matador

Surface mount & shallow mount security available with either Electromechanical or Manual operation.

Heald's multi-award-winning sliding bollard system, the Matador, is a patent-protected high-security system crash-tested to various PAS 68 and IWA standards. The Matador has revolutionised the perimeter security industry and has been recognised by numerous innovation awards for its various groundbreaking features.

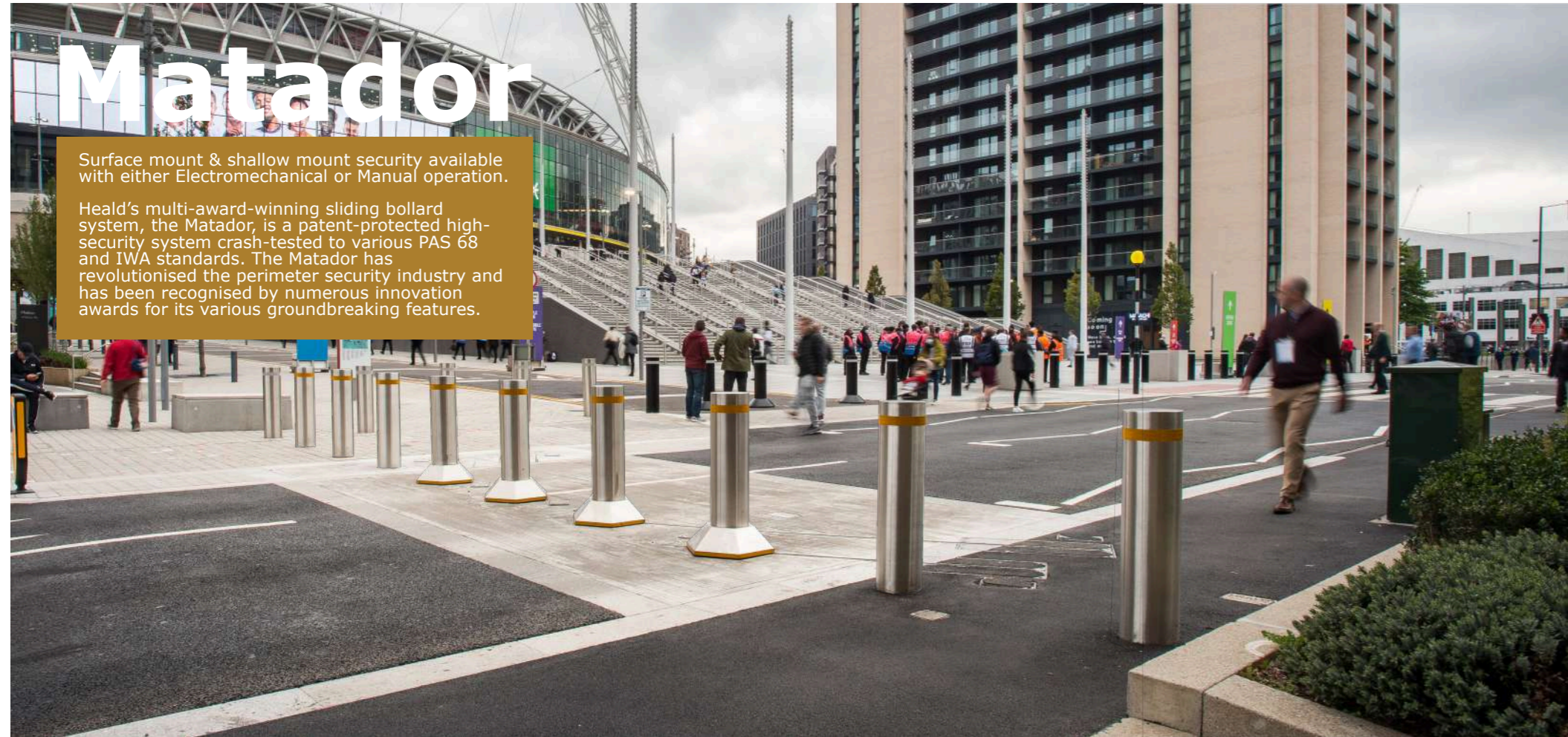

MATADOR 10

The Matador product range has been designed for installation at sites with congested underground services, alleviating the need for expensive diversions, and has proved its ability to protect underground utilities, transferring very little down force during its IWA crash-tests.

In crash-testing, the sliding bollard system arrested the test vehicle, achieving a zero-penetration rating and continued to function following the impact with no repairs required providing reliable protection for both life and infrastructure.

The innovative design of the sliding bollards of the Matador offers excellent pedestrian permeability and because of their sliding motion, the moving bollards are always visible minimising the chance of accidental damage. The Matador also features a completely flat surface when installed as a recessed product, meaning there are no trip or trap hazards, making the system extremely safe for pedestrianised areas.

The system is available with a wide range of options as standard, including Electromechanical or Manual operation, is customisable to suit client preferences, and can be made to bespoke requirements by our talented engineering team to fit installation sites with the most challenging of constraints.

MATADOR 11



HT2 Matador

Surface mount & shallow mount security bollards, available with either Electromechanical or Manual operation.

HVM Specification

PAS 68
V/7500(N2)/64/90:0.7/0.0
IWA 14.1
V/7200[N2A]/64/90:0.1

With a foundation depth starting from 150mm and an opening width of up to 6.8m the HT2 Matador is available in a wide variety of options and can be manufactured to bespoke specifications to suit the limitations of your site.

The HT2 Matador has proven its ability to resist the impact of a 7.5T N2 vehicle travelling at 40 MPH and achieved zero penetration. The Matador continued to function following the impact with no repairs required, providing reliable site access for emergency services and continued protection.

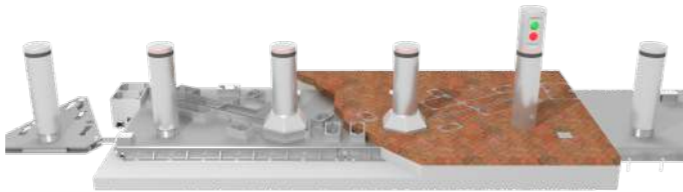

Patent Numbers

Granted US Patent - US9,315,956;
 Granted US Patent - US10,119,230;
 Granter EP Patent - EP2776631
 (GB, FR, SE, NO, NL, IT, DE, TR)

Standard Configurations (Additional Extras detailed on Pg17)

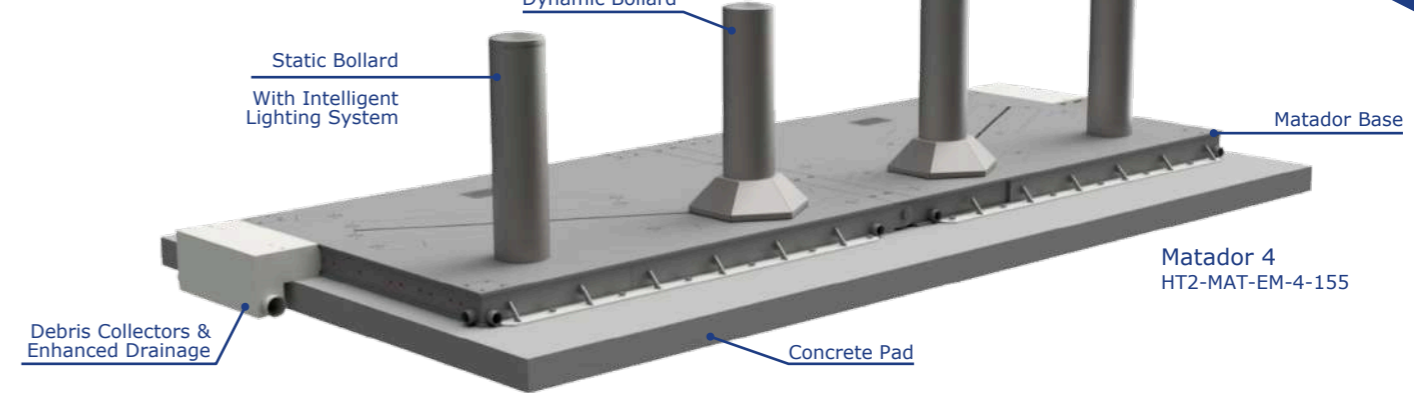

Matador 4
HT2-MAT-EM-4-155



Dimensions in mm

Model	No. Of Dynamic Bollards	Base Length	Base Width	Opening Width	EM Operating Speed (sec)		STD Bollard Height (inc. Covers)	STD Bollard Diameter (inc. Covers)
					Standard	EFO		
HT2 - Matador 3(1DB)	1	1980	3900	2574	6	3	1050	256
HT2 - Matador 3(2DB)	2	2680	3987.5	4011	12	6		
HT2 - Matador 4	2	1980	5315	4013	6	3		
HT2 - Matador 5	3	2860	6730	5404	12	6		
HT2 - Matador 6	4	2680	8145	6819	12	6		



HT3 Matador

Surface mount & shallow mount security bollards, available with either Electromechanical or Manual operation.



HVM Specification



IWA 14.1

V/7200[N3C]/64/90:1.3

V/7200[N2A]/80/90:3.2

Patent Numbers

Granted US Patent - US9,315,956;
 Granted US Patent - US10,119,230;
 Granter EP Patent - EP2776631
 (GB, FR, SE, NO, NL, IT, DE, TR)

Designed for locations that require higher security, this range has been dual tested to IWA standards, offering protection against the larger N3C vehicle class at 40mph and the N2A vehicle at 50mph.

During both tests the vehicles were halted with minimal penetration and continued to operate after impact.

The HT3 Matador has also undergone VADS delay rating testing, for temporary solutions.

Standard Configurations (Additional Extras detailed on Pg17)

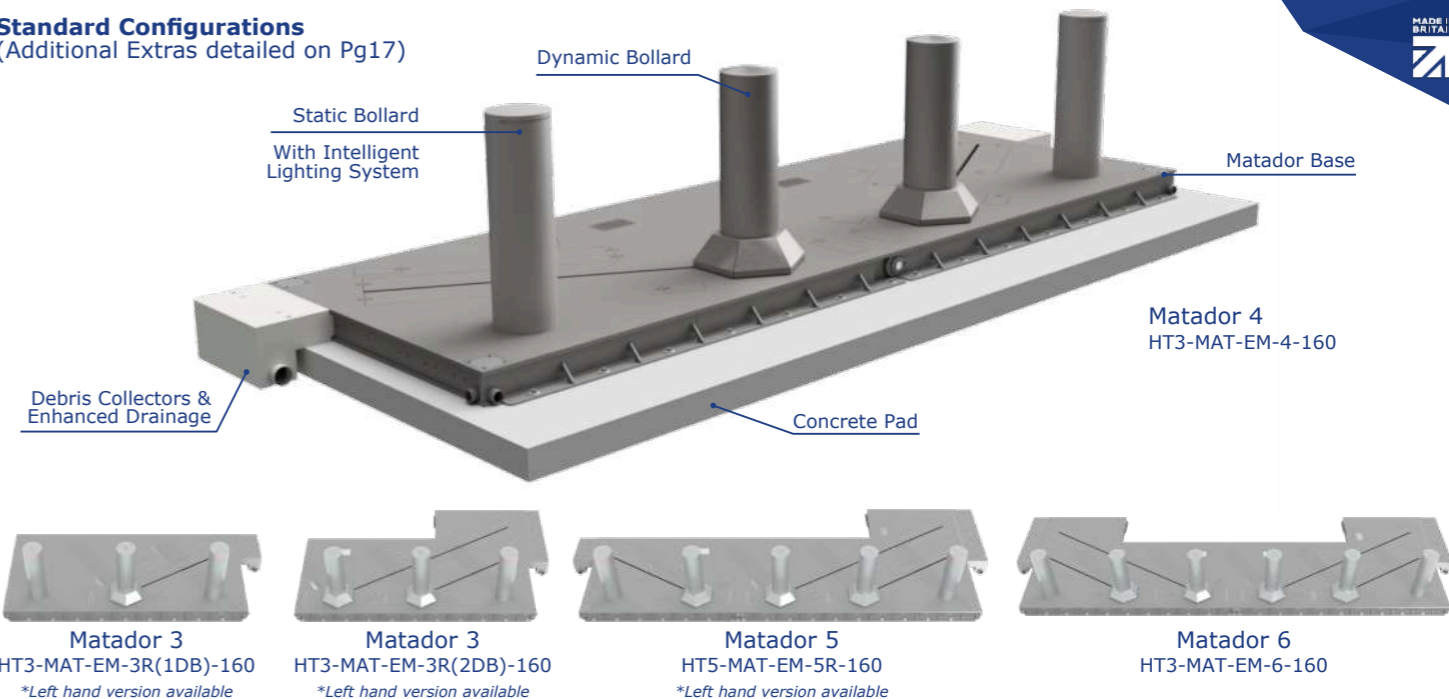

Matador 3
 HT3-MAT-EM-3R(1DB)-160
 *Left hand version available

Matador 3
 HT3-MAT-EM-3R(2DB)-160
 *Left hand version available

Matador 5
 HT5-MAT-EM-5R-160
 *Left hand version available

Matador 6
 HT3-MAT-EM-6-160

Dimensions in mm

Model	No. Of Dynamic Bollards	Base Length	Base Width	Opening Width	EM Operating Speed (sec)		STD Bollard Height (inc. Covers)	STD Bollard Diameter (inc. Covers)
					Standard	EFO		
HT3 - Matador 3(1DB)	1	2060	4016	2640	6	3	1050	306
HT3 - Matador 3(2DB)	2	2940	4218	4146	12	6		
HT3 - Matador 4	2	2060	5489	4113	6	3		
HT3 - Matador 5	3	2940	6929	5586	12	6		
HT3 - Matador 6	4	2940	8435	7059	12	6		

Fixed Matador

Surface mount & shallow mount security bollards

Available in two variants HT2 and HT3 the Fixed Matador design is based upon Heald's Award-Winning Matador (dynamic) range.

Arrays of 1, 2, or 3 No. Bollards fixed to the same base plate, with the ability to seamlessly join to additional Matador products to extend the protected line indefinitely.

The Fixed Matador offers several advantages over more traditional systems. Its surface mount installation is not only extremely fast and efficient, but it also allows for fitting in areas where even shallow mount is impossible; for example, sites with congested underground services alleviating the need for expensive diversions and has proved its ability to protect underground utilities, transferring very little down force during its IWA crash-test.

It can be installed with a minimum of disruption to the road surface, making it ideal for short term or temporary installations.

Patent Numbers

Granted US Patent - US9,315,956;
Granted US Patent - US10,119,230;
Granted EP Patent - EP2776631
(GB, FR, SE, NO, NL, IT, DE, TR)

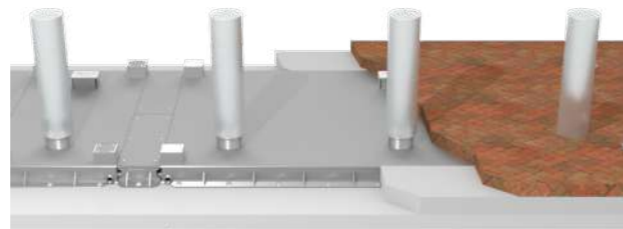

HVM Specification



PAS 68
V/7200(N2)/48/45

Temporary Matador

Surface mount security bollards Available in two variants, HT2 and HT3.

World's first surface mounted automated bollard system, suitable for temporary events.

The Matador has been tested as a completely surface mounted solution making it ideal for temporary events as well as a permanent solution. Whilst maintaining maximum security, the product can be bolted down onto a suitable surface and supplied with ramps.

As a temporary solution the Matador is available either as a Manually Operated solution or as an Electro-Mechanical system with power being supplied by a generator. The automated bollards can be operated via local push-buttons to provide convenient and easily controllable access to the event.

Hire of the Matador is suitable for both long-term and short-term events, please contact our sales team for more information about the products available for hire.

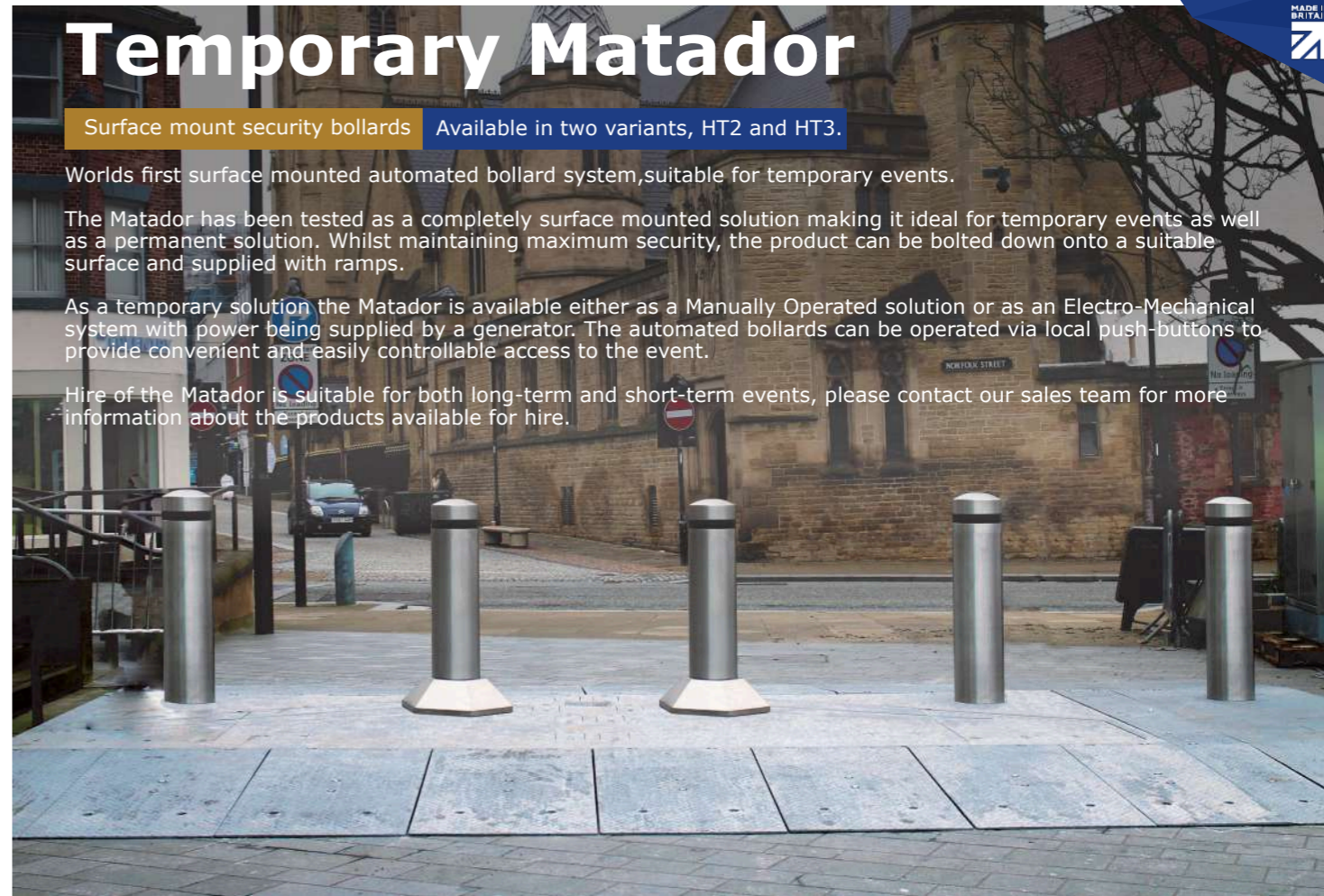

Matador Accessories

Due to the unique sliding motion of the bollards, there are multiple options for the bespoke cover designs on both the static and sliding bollards. Our standard options include Stainless-Steel covers with flat, semi-domed, sloped tops or cast aluminium ball top. We also offer options for lighting, traffic lights, bands and integrated access control panels within static bollards. All covers are available powder coated in any colour of your choice and we can provide bespoke options to match the aesthetic specification of the site including alternative materials, shapes, finishes, etc.



Stainless-Steel 316
Semi Domed Top

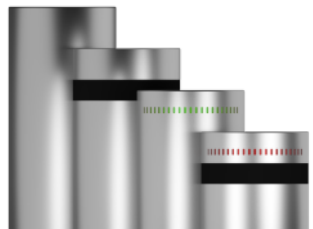

Stainless-Steel 316
Flat Top

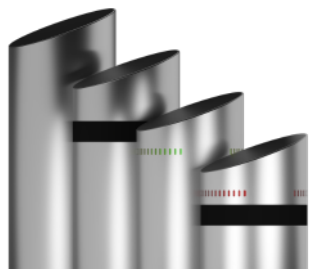

Stainless-Steel 316
Angled Top

MATADOR 18

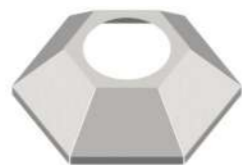

Stainless-Steel 316 Hex



Stainless-Steel 316
Round



Stainless-Steel 316 Heritage
Cover



Aluminium Cast Ball Top

Architectural Paving System

The Matador Architectural Paving System creates a seamless finish with the surrounding landscaping across the surface of the Matador.

The Heald Architectural Paving System consists of a tray system which provides either **80mm** or **110mm** of space to lay finishes on top of the base plate of the Matador. This allows for the Matador surface to be finished using either paving, asphalt, concrete, or other surfacing material to tie in with surrounding architecture. The paving system has been designed with easily removable trays to ensure ease of access to internal components for maintenance and servicing. With the increased depth of the Architectural Paving System, the Matador remains a shallow mount solution with a base depth range of 235mm to 270mm depending on the model (not including the concrete base).

Architectural Paving System (APS)

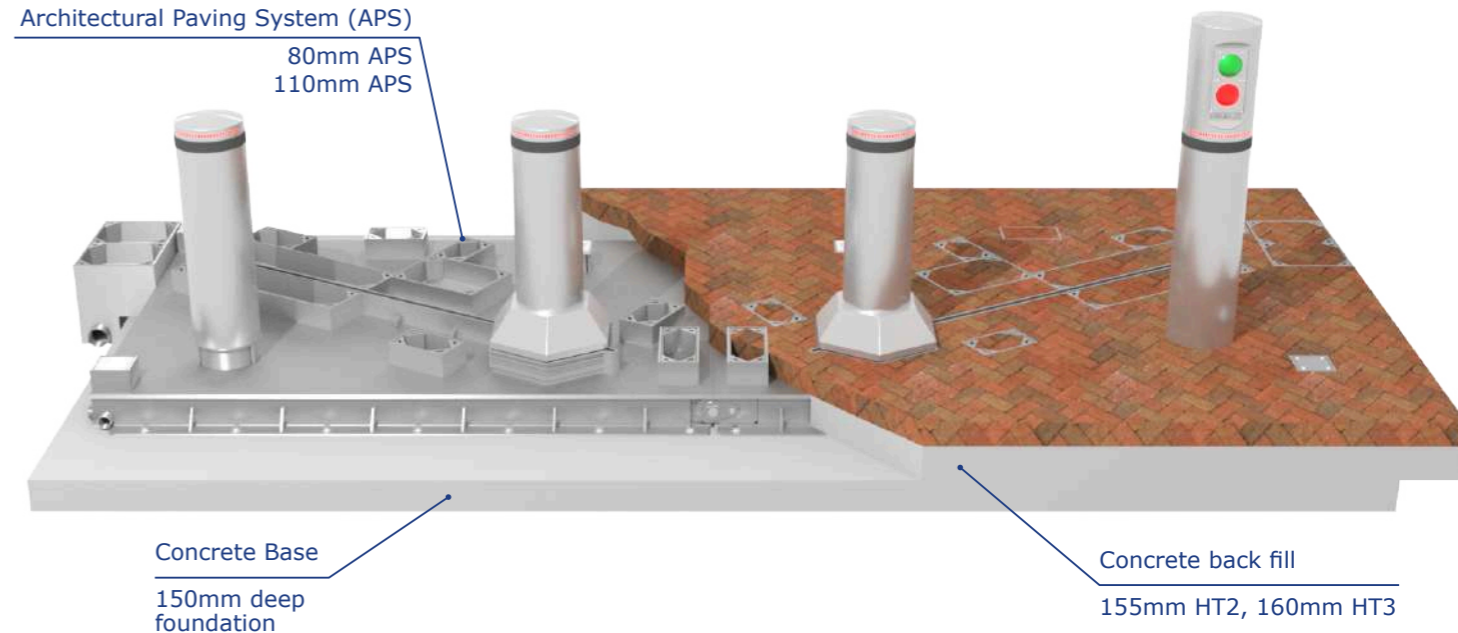

MATADOR 19

Matagate

A new product from Heald for 2026. The Matagate is a adaptation of our highly successful Matador product. A revolution within the HVM gate space, providing a shallow mount foundation of as little as 150mm whilst being able to resist attacks from vehicles travelling at a speed of 50mph (80km/h).



MATADOR 20

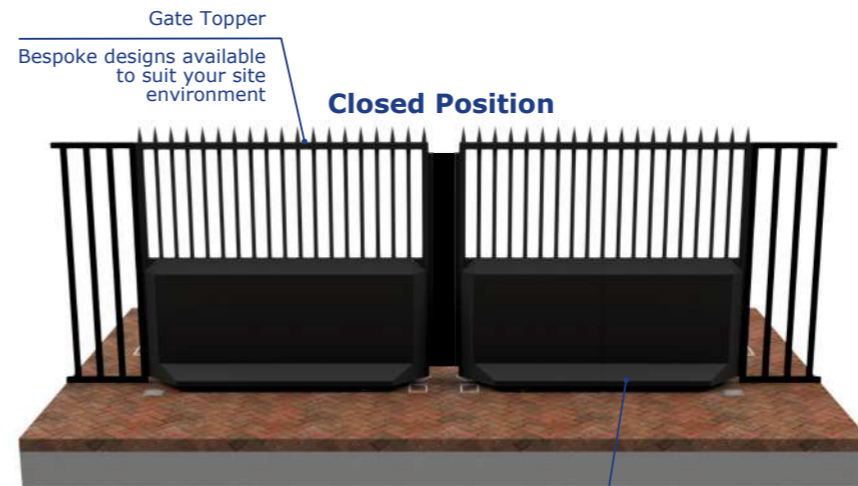

Designed for both the HT2 and HT3 Matadors.

The Matagate is a truly versatile product, providing a sleek modern take on HVM gate design.

MATADOR 21

HT1 Raptor

Heald's revolutionary rising bollard design is like nothing else on the market, combining the high security of a blocker with the flexibility of a bollard. The totally unique design provides exceptional protection for underground services, people and infrastructure in a package with a modern and distinctive aesthetic. Electromechanical, Hydraulic and Manual operation available.

HVM Specification



ASTM: C40 P1 Zero Penetration
 ASTM: M50-P1 Zero Penetration SD-STD2.01 K12
 PAS68: Blocker/Bollard V/7500[N3]/80/90:3.3/18.9

Patent Numbers

Granted US Patent - US8,979,419
 Granted US Design Patent - D715174
 Granted EP Patent - EP2561140
 Granted GB Patent - EP2561140

The Raptor system is a flexible shallow-mounted HVM Crash-Rated Bollard solution which is simple and easy to install and seamlessly integrates with Heald's HVM Static Bollard Range. Patent protected, triple tested and operational after impact truly makes the Raptor unique amongst its competitors.

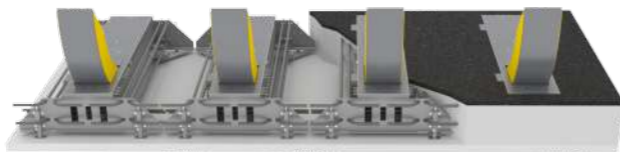

Raise Height	985mm
Bollard Width	380mm
Foundation Depth	480mm
Operation	Electromechanical Hydraulic Manual
Standard Operating Speed	4-6 seconds (EM & HYD) 30 seconds (Manual)
EFO (Emergency Fast Operation)	1.5 seconds
Finish	Galvanised & Painted any colour of your choice

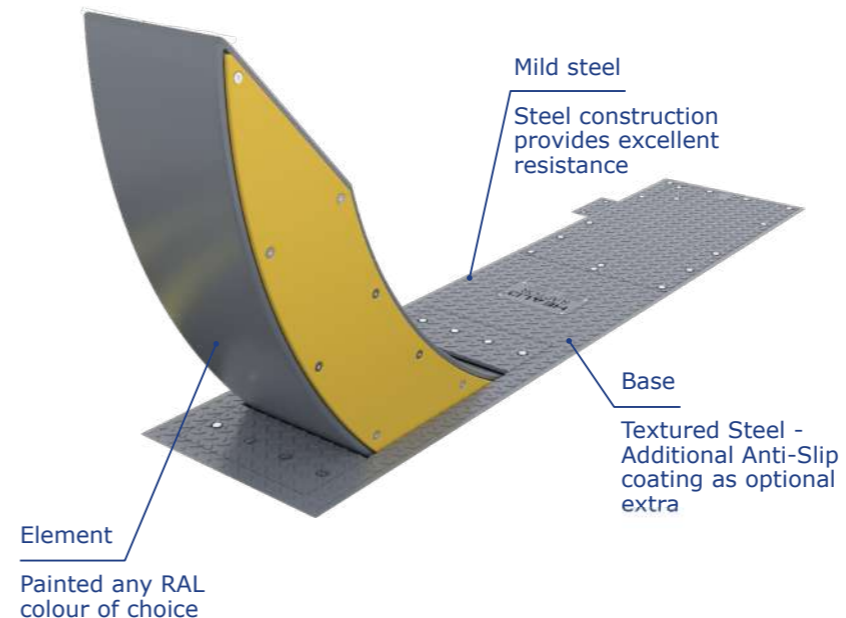

Heavy-Duty wear plates - Colour option



Yellow



Red



Green



Burgundy



Blue



Black

Heavy-Duty wear plates

Colour options available (See above)

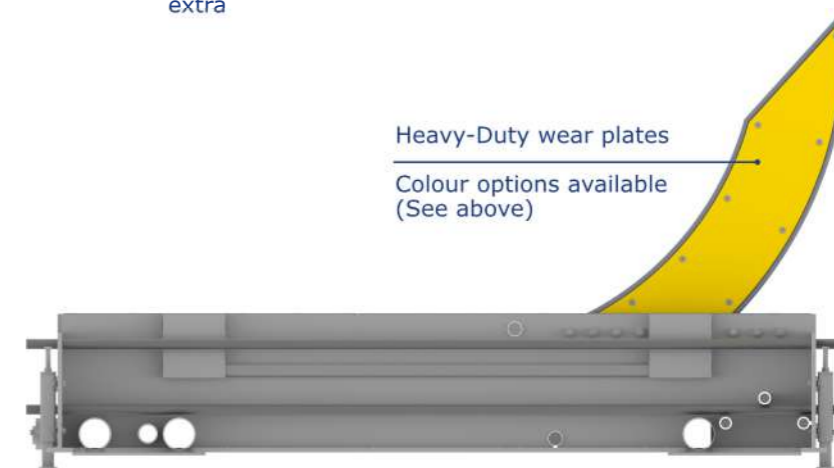

EVO Bollard

Heald's EVO Bollard is a patent-protected high-security system with unique features unlike any other rising bollard on the market. Rising to 1m, the EVO requires only a 1.1m excavation and coupled with its unique internal reinforcement it is the most resistant HVM bollard on the market.

Heald currently offer the Crash Tested HT2-EVO (7.2T @ 40mph) and the HT3-EVO (designed for 7.2T @ 50mph) which has a slightly taller bollard (1.1m) and slightly deeper excavation (1.2m).



Patent Numbers

Granted US Patent - US10,385,528
 Granted EP Patent - EP3341524
 (GB,FR,SE,NO,NL,IT,DE,TR)

HVM Specification



IWA14-1: 2013 Bollard V/7200[N2A]/64/90:1.3

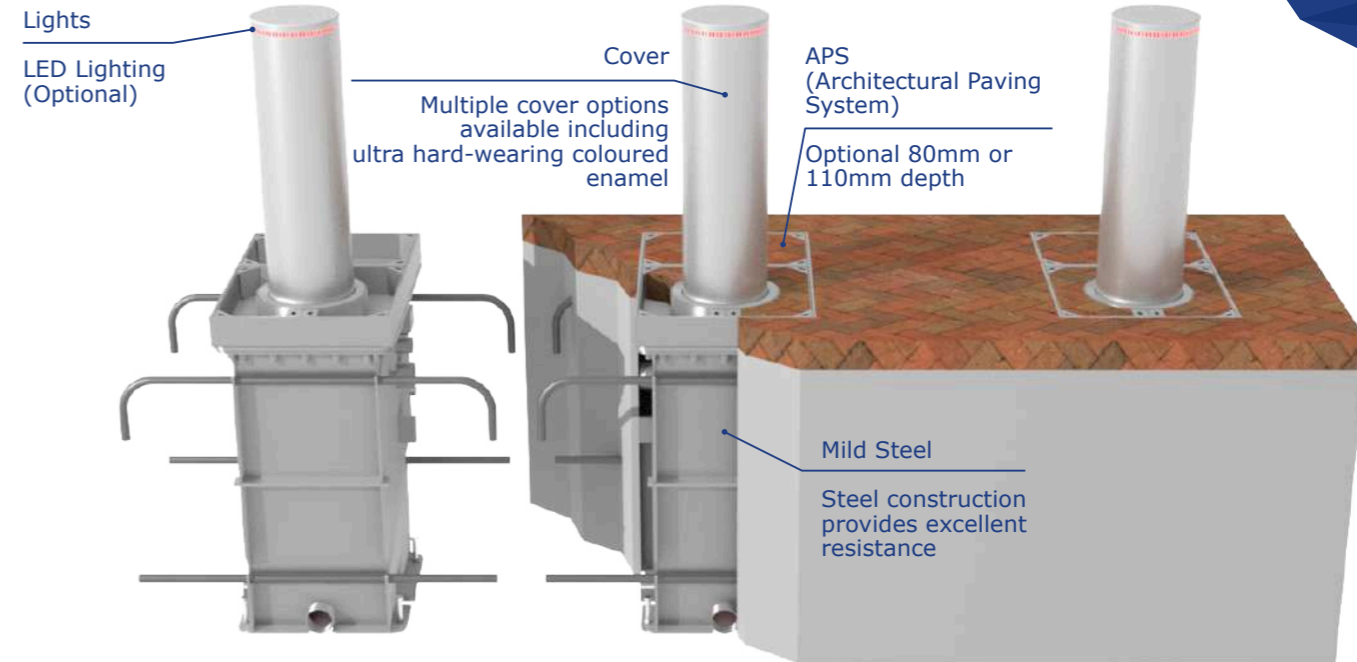

Dimensions in mm

Model	Raise Height	Bollard Diameter	Foundation Depth	Operation	Standard Operating Speed	EFO (Emergency Fast Operation)	Finish
HT2	1000	306mm (inc. Cover)	1100	Electromechanical Manual Hydraulic	6 seconds Automatic	1.5 seconds	Galvanised with Grade 316 Stainless-Steel or ultra hard-wearing coloured enamel finish
HT3		356mm (inc. Cover)	1200		30 seconds Manual	2 seconds	

Mantis-64

Mantis-80

Heald's Mantis Bollard is an incredibly resistant static bollard, tested as a single unit. Offering high security combined with a rapid, low-cost installation, the Mantis is a viable alternative to deep mount static bollards.

Heald's Mantis Bollards have been triple tested with the Mantis 64 crashed to PAS68 standards. The Mantis-80 is crash tested to IWA-14-1 standards and an array of 3 No. Mantis-80 bollards is also crashed to the IWA-14-1 standards, all passing their respective tests at either 64kph (40mph) or 80kph (50mph).

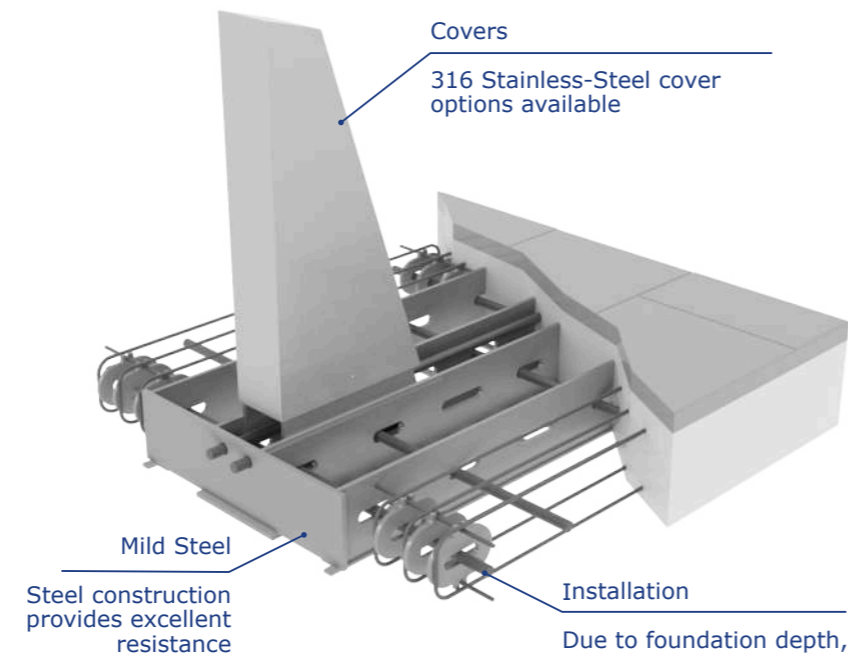

HVM Specification

Mantis-64



PAS68: V/7500[N2]/64/90:0.0/0.0

Mantis-80



Single Bollard Test

IWA14-1: V/7200[N3C]/80/90:7.5

Array of 3 test - IWA14-1: V/7200[N2A]/80/90:3.5



Bollard Height	1130mm
Bollard Width	196mm (inc. Cover)
Foundation Depth	Mantis-64: 250mm Mantis-80: 300mm
Finish	Primed with Grade 316 Stainless-Steel covers. Galvanised/Painted finish also available
Options	LED lighting options available, alternative colours and patterns are available

APEX-64 APEX-80

Heald's APEX Static Bollard provides a shallow mount solution that is designed to flexibly adapt to a wide variety of locations and topographies due to its innovative modular design. With no modification required, the APEX Bollard can be installed on various gradients and can create angled and curved arrays giving Architects and Installers the flexibility to create the security solution they need without restrictions.

The APEX Bollard was designed to enable simple and fast bollard installation in either a straight line or a curved array and the innovative connection plates ensure 1.2m gap between bollards can never be exceeded; providing confidence of compliance with HVM standards for both Architects and Installers.

The circular bollard is suitable for a variety of aesthetic finishes and covers (including lighting options and access control options for adjacent automated products), providing a seamless protective perimeter to both historic and contemporary architecture.

Due to the unique design of the APEX bollard, tight curves and 90-degree angles are achievable without any modification to the bollard base. The bollard is mounted onto the base plate which is elongated to the rear of the product which projects into the protected space. Due to this shape, there are two maximum achievable radii for the curvature of the bollard line; this can be either towards or away from the protected area.

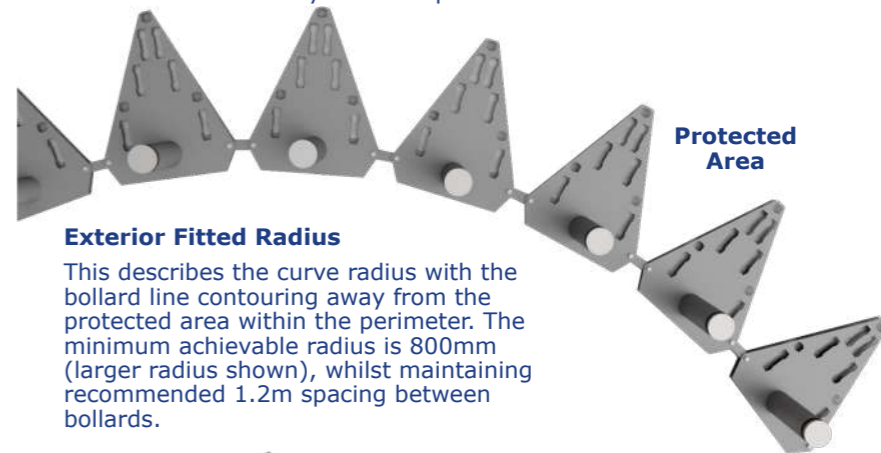

Exterior Fitted Radius

This describes the curve radius with the bollard line contouring away from the protected area within the perimeter. The minimum achievable radius is 800mm (larger radius shown), whilst maintaining recommended 1.2m spacing between bollards.

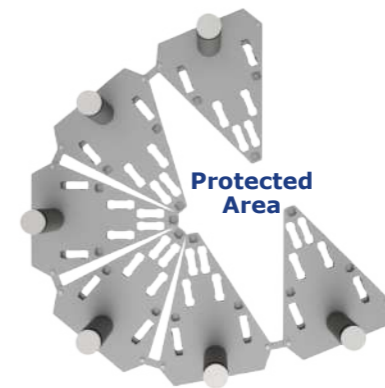

Interior Fitted Radius

This describes the curve radius with the bollard line contouring towards the protected area within the perimeter. The minimum achievable radius is 1550mm (shown), whilst maintaining recommended 1.2m spacing between bollards.

APEX-64 APEX-80

Heald's APEX Static Bollard is available as the Crash Tested APEX-64 (40MPH version) or as the APEX-80 (50MPH) which has a larger bollard diameter.

APEX-64 was crash tested as an array of 3 bollards and showed minimal deflection of the bollard after the crash.

Closing Gaps

Both APEX-64 and APEX-80 can be used in conjunction with Matador and EVO bollards to close gaps in the protected line. Single APEX bollards can be connected to Matador and EVO utilising Heald's proprietary joining units to maintain the crash resistance across the entire array.

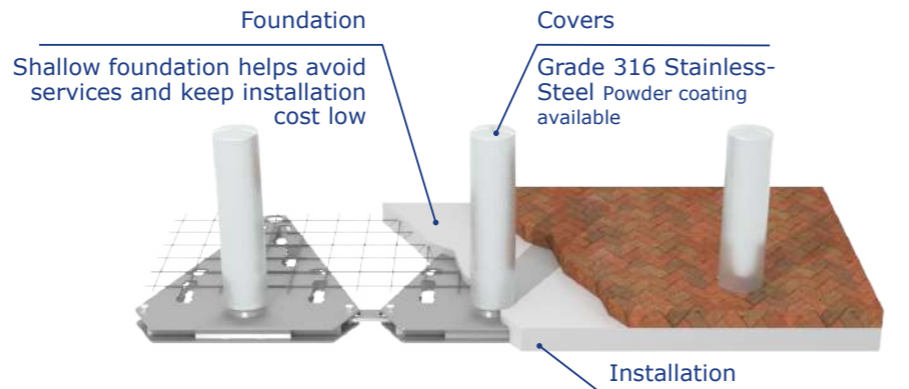

APEX on stepped elevation with cranked connection plates



HVM Specification

APEX-64



40
MPH

64
KM/H

IWA 14-1:
V/7200[N2A]/64/90:3.7
(Minimum array of 3)

Dimensions in mm

Model	Bollard height (inc. cover)	Bollard Diameter (inc. cover)	Foundation Depth	Finish
APEX-64	1050	256	Starting from 150mm dependant on sub-base	Galvanised with Grade 316 Stainless-Steel cover
APEX-80		306		

APEX-64 Removable

The APEX-64 Removable Bollard was designed to enable simple and fast bollard installation with the additional ability to remove the bollard from locations that may on occasion require access for the likes of parades, large events and larger vehicles.

An engineered solution based upon Heald's standard crash tested APEX-64.

Covers
Grade 316
Stainless-Steel
Powder coating available

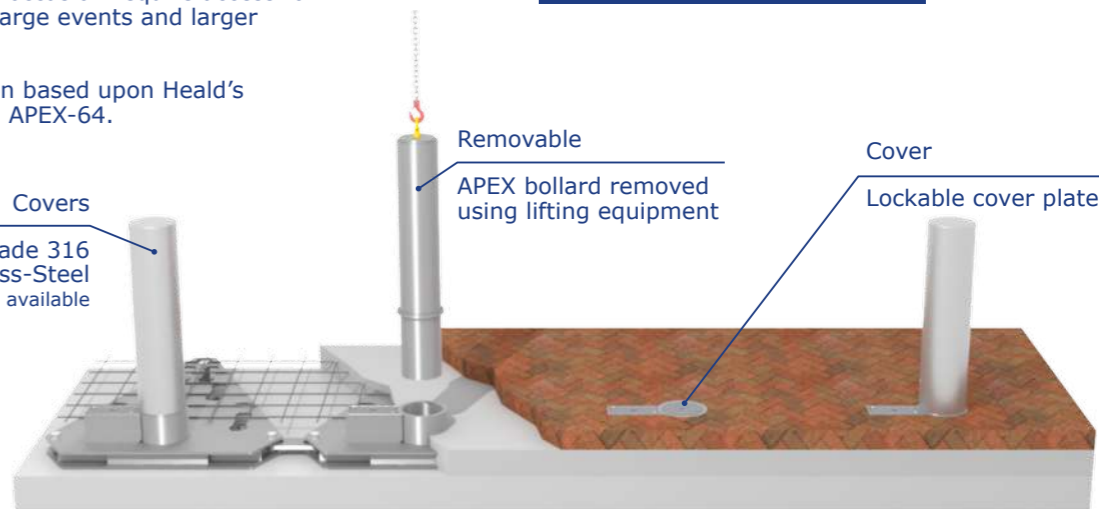

HVM Specification

APEX-64 Removable - Designed For..



40
MPH

64
KM/H

Design Number:

UK design number - 6145254

Dimensions in mm

Bollard height (inc. cover)	Bollard Diameter (inc. cover)	Excavation Depth	Product Weight (Total)	Removable Bollard Weight	Finish
1050	256	Starting from 365mm dependant on sub-base	600Kg	200Kg	Galvanised with Grade 316 Stainless-Steel cover

SYNERGY BOLLARD

Heald's Synergy static bollards are designed primarily to secure bridges against hostile vehicle attacks but are also capable of securing a wide range of locations including inner cities and footways.

Heald's Synergy Bollard system consists of nine fixed bollards on base plates which are bolted together and due to its unique design, there is no requirement to bolt the bollard to the ground.

HVM Specification

Synergy Bollard



IWA 14-1:
V/7200[N3C]/48/30:0.9
(Minimum array of 9)
V/7200[N3C]/48/90:4.2

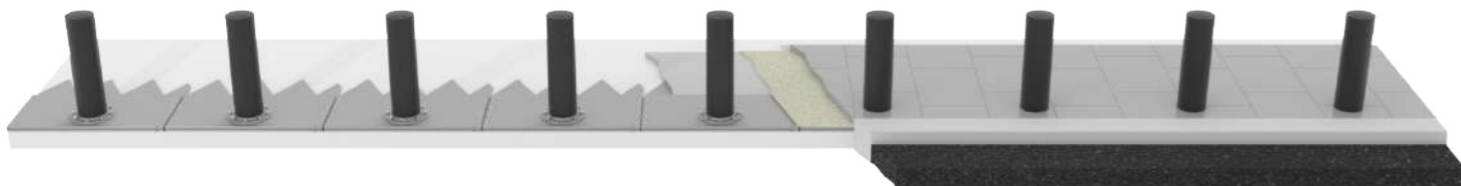

EXPANSION UNIT

Patent Number: GB Patent Application Number - GB20000701.9

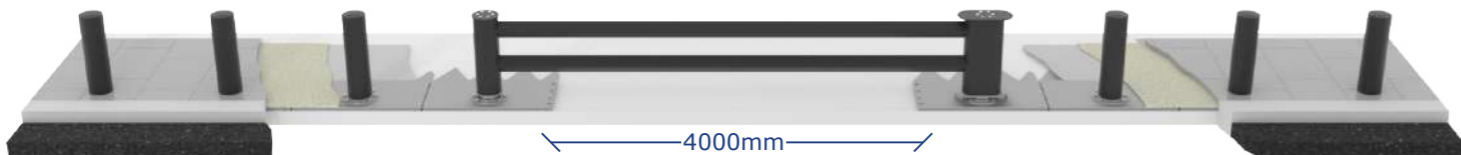

HVM Specification

Synergy Expansion Joint Unit



IWA 14-1:
V/7200[N3C]/48/30:0.2

Heald's Synergy Expansion Joint Unit consists of a 5400mm barrier creating a free space of 4000mm between the two bollards as part of the Heald Synergy Bollard System.

The Expansion Joint Unit was designed to provide capacity for bridge expansion, allowing for lateral movement of up to 150mm. The unique design requires no pinning and no excavation into the carriageway. Alternative barrier lengths are available on request.



Dimensions in mm

Model	Bollard height (inc. cover)	Bollard Diameter (inc. cover)	Foundation Depth	Finish
Synergy Bollard	1050	256	130	Galvanised, Primed and Painted Stainless-Steel covers
Expansion Unit		273mm circular cover on beam LHS 273mm pill shape on Beam RHS with 150mm between centres to allow for 75mm lateral movement in either direction.		Galvanised, Primed and Painted

SPARTA BOLLARD

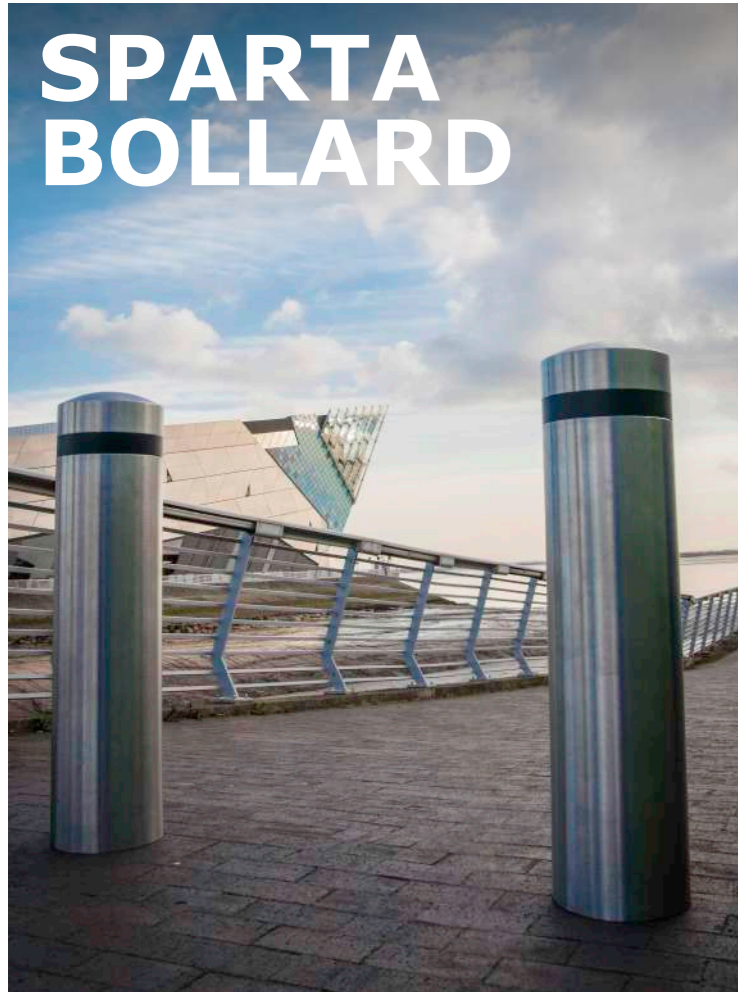

SPARTA 34

Heald's Sparta static bollards provide a simple, cost-effective solution for creating robust HVM defensive lines.

The Sparta Bollards are available in three security levels to protect from impacts at either 48kph (30mph), 64kph (40mph) or 80kph (50mph). Each variant has been tested to PAS68 standards, against a 7.5 tonne truck as an array of 3 bollards with the vehicle impacting on a single bollard, all bollards stayed intact providing continued protection.

Removable Sparta

Variant



An evolution of our fixed Sparta range providing the same simple, cost-effective solution for creating robust HVM defensive lines.

The Sparta Removable Bollard has the same reinforced foundation as the Fixed bollard with the addition of an in ground socket used to lock the bollard in place, useful for locations that may require occasional access for parades, larger vehicles, maintenance vehicles and more.

HVM Specification

Sparta 48



30 MPH

48 KM/H

PAS68:

V/7500[N2]/48/90:0.0/0.0

HVM Specification

Sparta 64



40 MPH

64 KM/H

PAS68:

V/7500[N2]/64/90:3.3/0.0

HVM Specification

Sparta 80



50 MPH

80 KM/H

PAS68:

V/7500[N3]/80/90:3.3/18.9

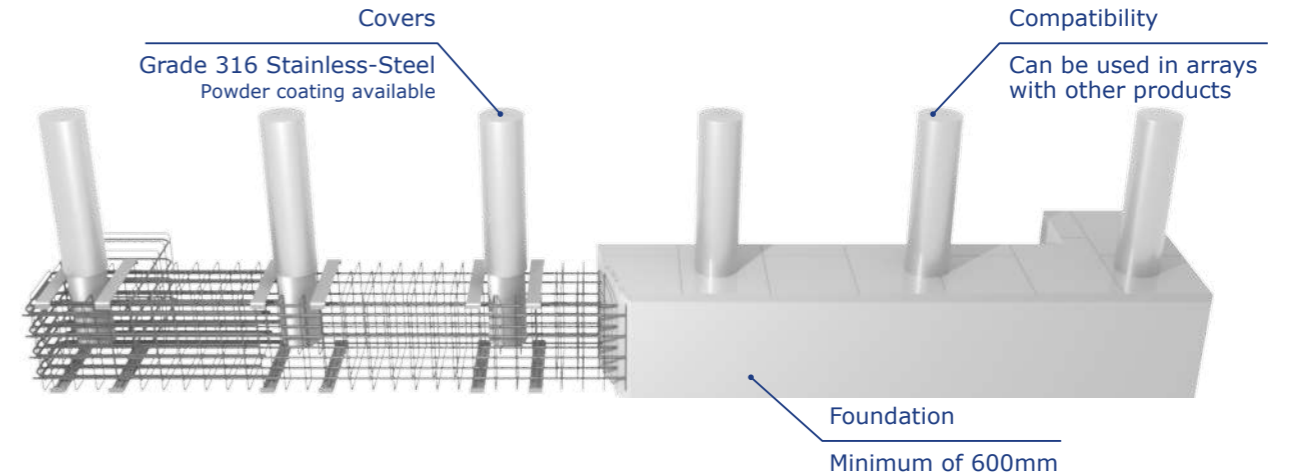

Dimensions in mm

Model	Bollard height (inc. cover)	Bollard Diameter (inc. cover)	Foundation Depth	Finish
Sparta 48	1050	256	600	Bollard Galvanised & Primed Stainless-Steel covers LED lighting and various bespoke cover options available
Sparta 64		273	800	
Sparta 80				



SPARTA 35

HEAVY-DUTY AUTOBOLLARD

Rising to a height of either 640mm or 800mm, our Heavy-Duty AutoBollards succeeded in halting a 6.8 tonne truck travelling at 64kph (40mph), in the US K8 impact test.



HVM Specification
Heavy-Duty AutoBollard

40 MPH

6.8T

64 KM/H

US K8: 6800/64(6400mm)

HEAVY-DUTY AUTOBOLLARD 36

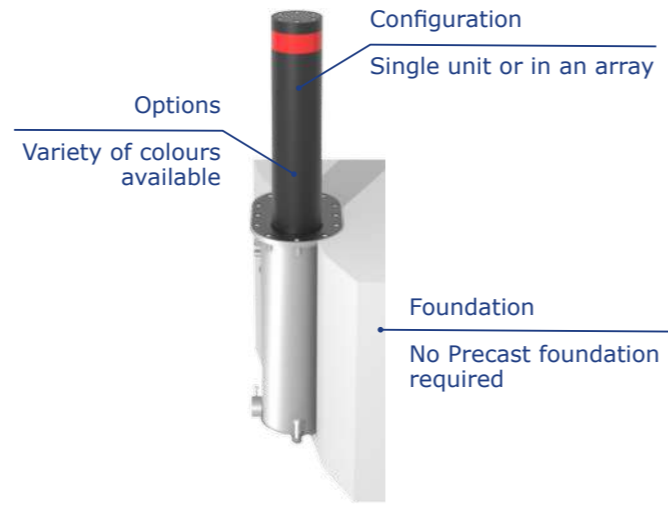

Dimensions in mm

Model	640	800
Raise Height	640	800
Bollard Diameter	220	220
Foundation Depth	1100	1250
Standard Operating Speed	3-4 Sec.	3-4 Sec.
EFO (Emergency Fast Operation)	1.5 Sec.	1.5 Sec.
Finish	Full Product Galvanised, Painted any colour of your choice	

ANTI-VANDAL AUTOBOLLARD

Heald's Anti-Vandal AutoBollards are ideal for locations where a more architecturally sensitive security solution is required as a deterrent to would be attackers.

Built using the same base structure to the Heavy-Duty AutoBollards, the non-tested bollard is constructed using the same robust methodology but utilising lighter materials.

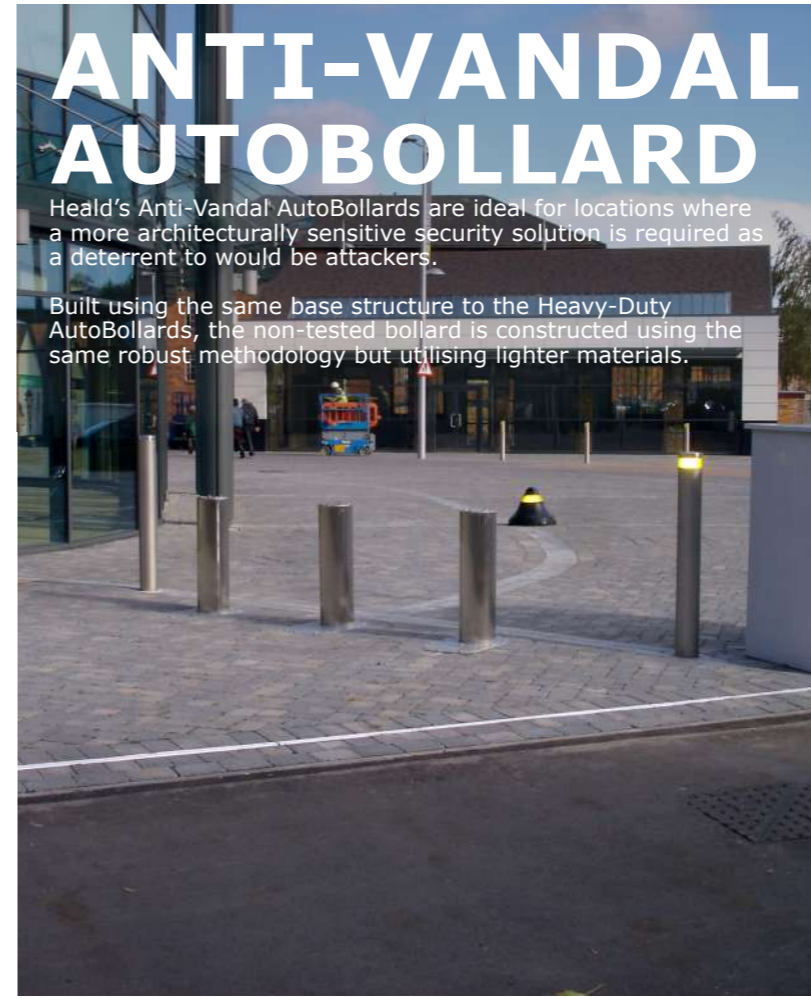

Dimensions in mm

Model	640-5	640-8	800-5	800-8
Raise Height	640		800	
Bollard Diameter	220		220	
Foundation Depth	1100		1250	
Standard Operating Speed	3-4 Sec.		3-4 Sec.	
EFO (Emergency Fast Operation)	1.5 Sec.		1.5 Sec.	
Finish	Full Product Galvanised, Painted any colour of your choice			

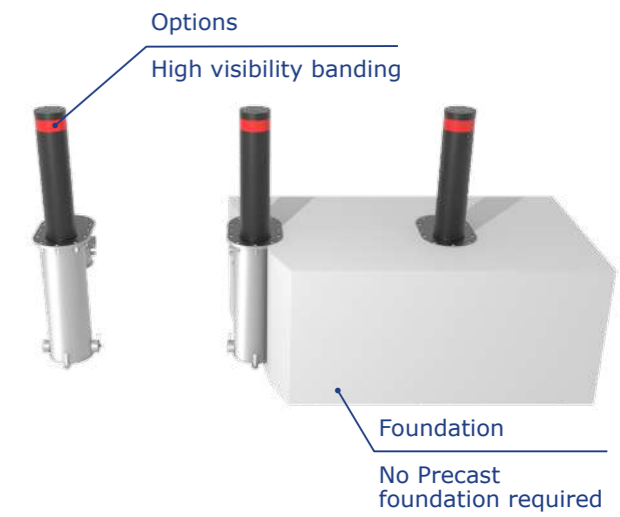

ANTIVANDAL AUTOBOLLARD 37



CONNECTING PRODUCT

Heald's product range has been designed with product combination in mind, allowing you to choose a product array to suit your site.

In situations where a Matador is selected and a small gap is left between the HVM array and any onsite feature (building) our joining units can be used to connect static bollards, closing the gap and ensuring your location is HVM compliant.

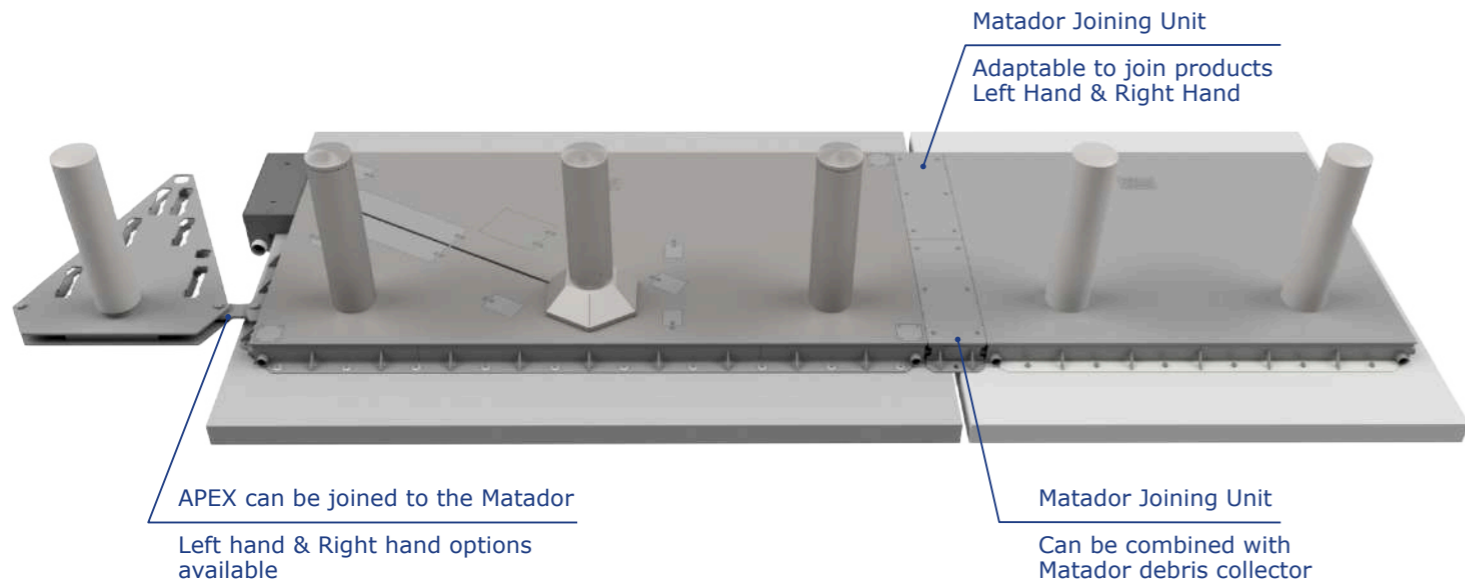

Should our standard range not suit the exact site requirements, our engineering team will be able to assist and create bespoke solutions to ensure the end result is compliant with regulations and specifications.

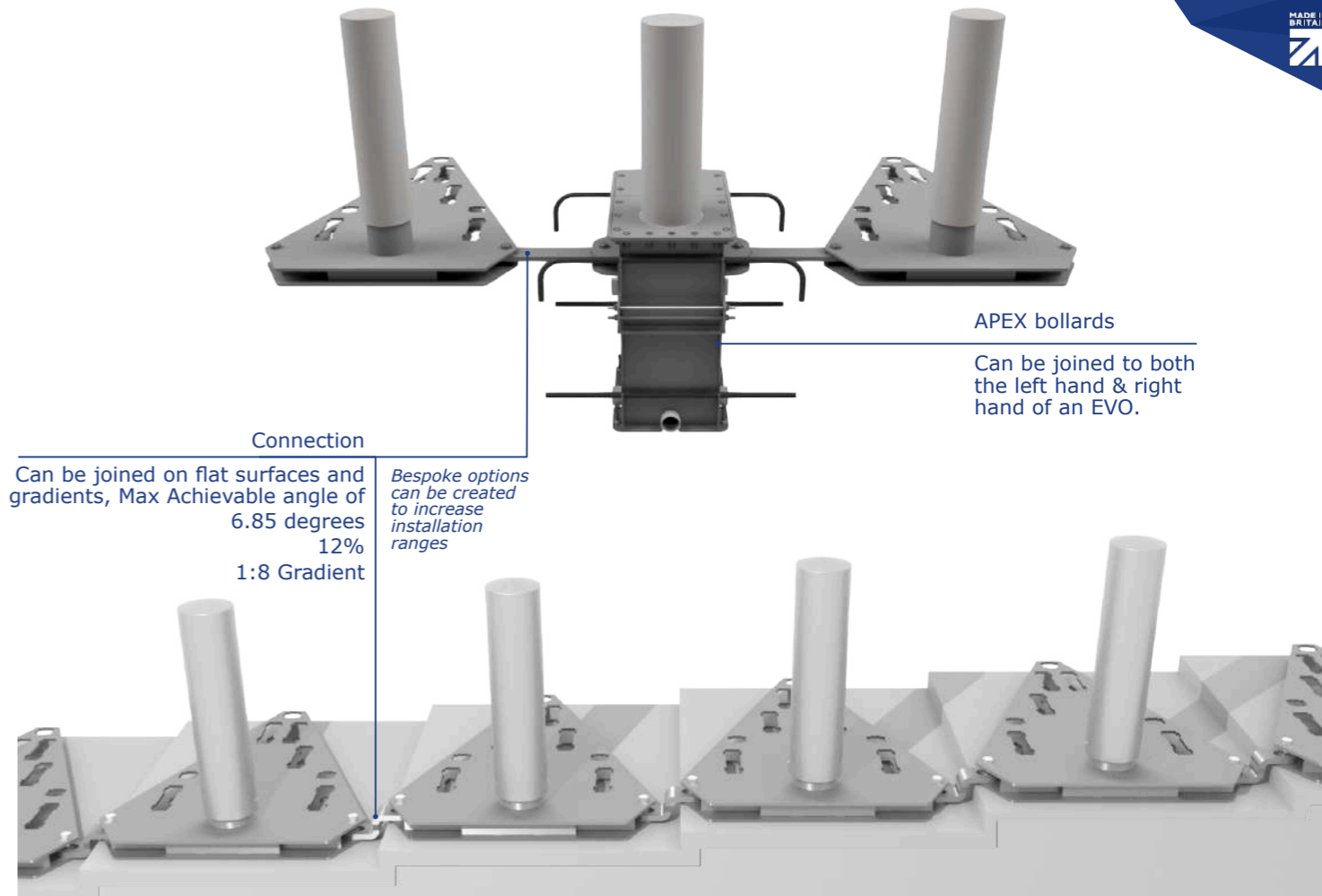

VIPER ROADBLOCKER

Hydraulic Electromechanical Manual

Heald's Viper is a high security roadblocker, rated to 50mph (80kph) with a foundation as shallow as 380mm. An imposing figure in the roadblocker market.

The Viper system is a shallow mount high security roadblocker which due to its ingenious folding skirt design only requires a foundation depth of 380mm, dependent on drive variant. Standing at 1050mm tall when fully raised, finished with bright yellow and black stripes for high visibility as standard (other colours available).

HVM Specification

Viper



7.5T



50
MPH



80
KM/H

ASTM: ASTM 2656-07 M50:P1
PAS68: V/7500[N3]/80/90:0/24.6

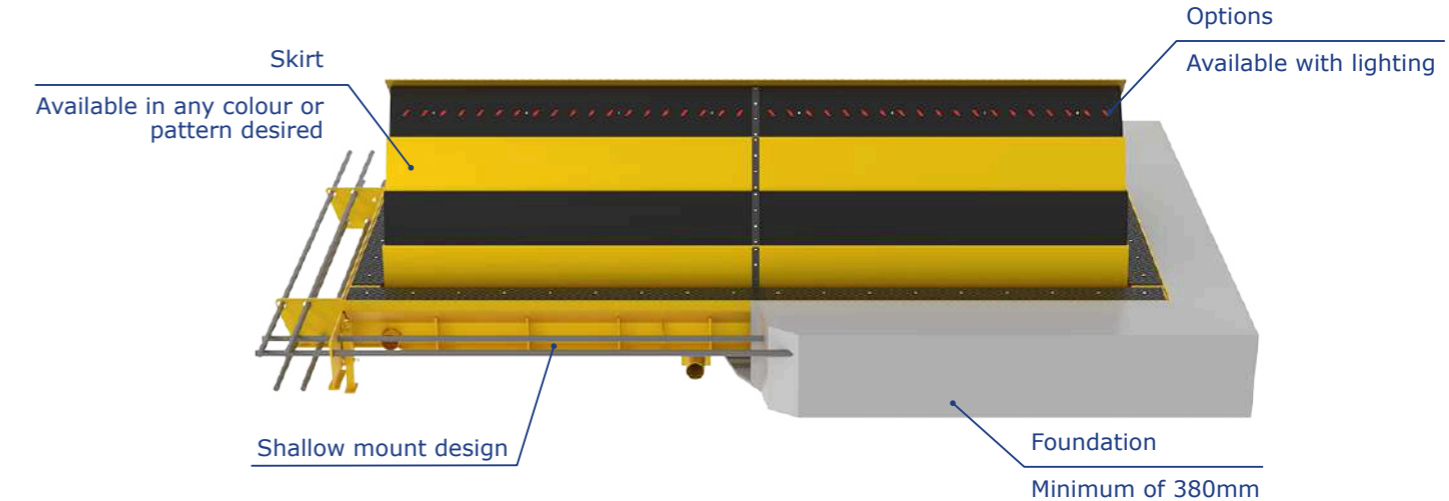

Dimensions in mm

Model	Raise Height	Blocker Width	Foundation Depth	Standard Operating Speed	EFO (Emergency Fast Operation)	Finish
Hydraulic	1050	Available with Wedge widths of 1.8m, 2.5m, 3.0m, 3.5m, 4.0m	380	6 Sec.	1.5 Sec.	Full Product Hot Dip Galvanised
Electromechanical	1030		460	6 Sec.	1.5 Sec.	
Manual			75 Sec.	N/A	Painted any colour of your choice	

COMMANDER

Heald's Commander Automatic Roadblocker is the world's only security barrier PAS68 tested to stop a 30-tonne truck travelling at 80kph (50mph). Following the crash test, the Roadblocker continued to function.

Standing at 1165mm above the ground and presenting an imposing barrier to potential attackers or terrorists, there is simply no alternative if you need the highest level of security.

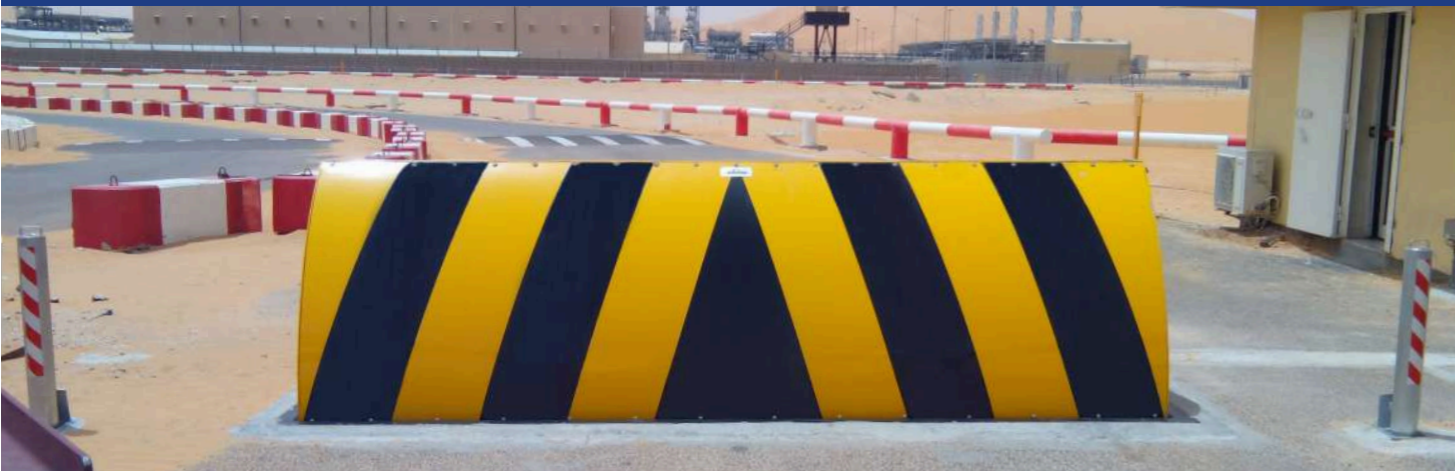

HVM Specification
Commander

30T 50 MPH 80 KM/H

PAS68: V/30000[N3]/80/90:0.0/6.9

Dimensions in mm		Model	Raise Height	Blocker Width	Foundation Depth	Standard Operating Speed	EFO (Emergency Fast Operation)	Finish
		Hydraulic	1165	3.0m or 4.0m	1500	6 Sec.	2 Sec.	Full Product Galvanised, Painted any colour of your choice

PAS 68 ROADBLOCKER



Heald's PAS68 Roadblockers are the perfect solution for security installations where a crash-rated, high-profile deterrent is required.

Available in two different heights to create an imposing barrier when fully raised, they stand at 880mm or 1200mm above finished floor level dependent on the model chosen. As standard the Roadblockers come finished with bright yellow and black chevrons for high visibility (alternative colours are available).



Dimensions in mm	
Model	Hydraulic
Raise Height	1165
Blocker Width	Incremental sizes from 2.0m – 6.0m
Foundation Depth	1500
Standard Operating Speed	6 Sec.
EFO (Emergency Fast Operation)	1.5 Sec.
Finish	Full Product Galvanised, Painted any colour of your choice

HVM Specification

PAS 68 Roadblocker

7.5T 50 MPH 80 KM/H

PAS68: V/7500[N2]/80/90 : 0/25
 PAS68: V/7500[N3]/80/90 : 0.0/14.3
 DOS K12: UPR/SSI/079/07K12 Certification

TRAFFIC CONTROL

Heald offers an extensive range of traffic control products. Ranging from traffic flow plates to arm barriers, we always have a product that is suitable for your site. Built to high-quality standards, our traffic control products are suitable where authorised entry or one-way traffic control is required, such as a car park.

The **MINI VIPER** is an in-ground or surface mount, Anti-Vandal system, offering a flexible security solution for all locations and can be installed as a temporary access control point.

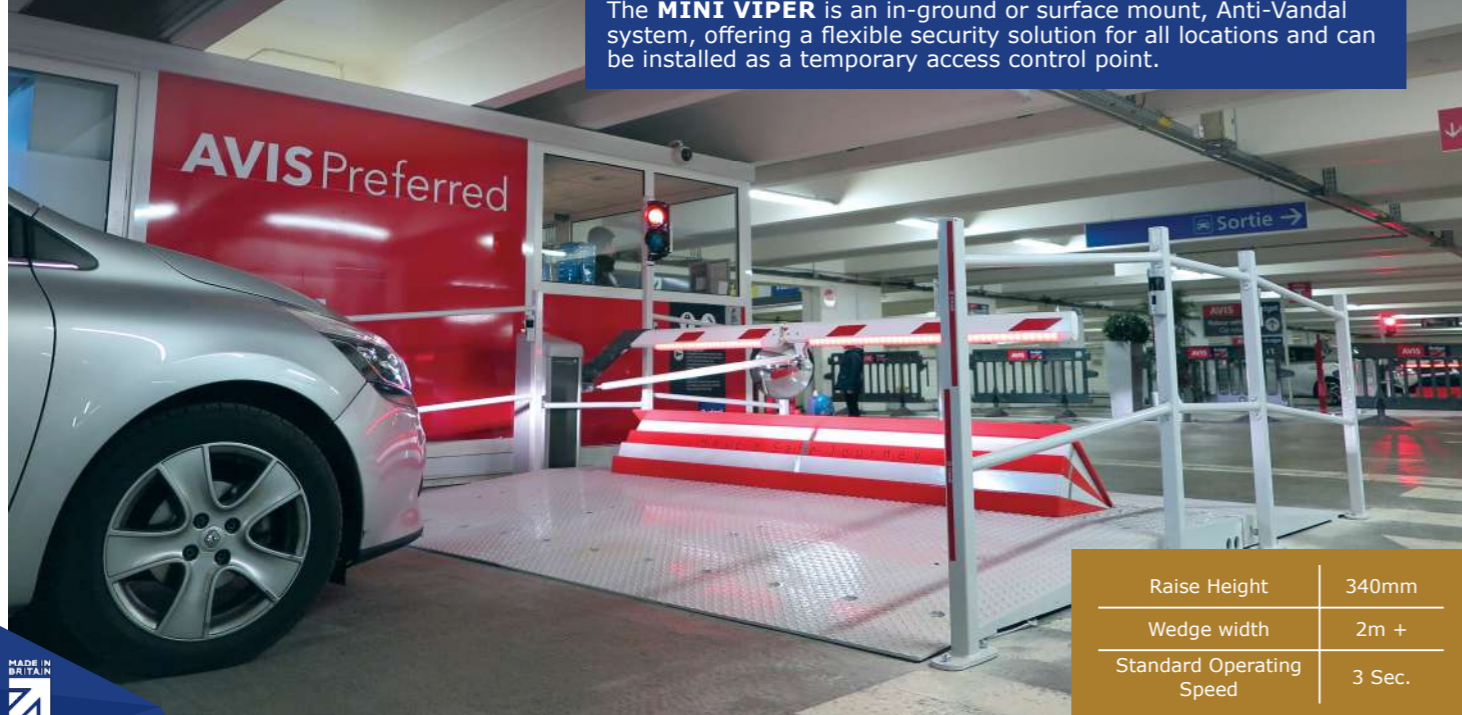

Raise Height	340mm
Wedge width	2m +
Standard Operating Speed	3 Sec.



RBAV ROADBLOCKER

Heald's Anti-Vandal Roadblocker is designed to present an imposing security barrier to any would be attackers.

<i>Dimensions in mm</i>	
Raise Height	340, 540, 650, 800
Wedge width	2.0m, 2.6m, 3.0m, 3.6m, 4.0m, 4.6m, 5.0m, 5.6m, 6.0m
Standard Operating Speed	2 - 5 Sec.

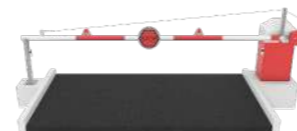

ARM BARRIER

The Arm Barrier is the ideal product to aid with traffic management and is suitable for use in locations such as car parks, airports and traffic control areas.

Width	Available in widths up to 8m
Standard Operating Speed	3 Sec.

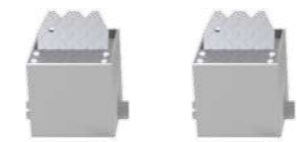

TRAFFIC FLOW PLATES

Heald's Traffic Flow Plates offer a practical, cost-effective solution for ensuring the direction of traffic is as required in a given area.

Width	Available in widths up to 8m
Raised Height	110mm
Foundation depth	250mm





HYDRA

By HEALD
SECURITY CONTROL SYSTEM

Heald's Hydra is a revolutionary remote control and monitoring system, designed to simplify and streamline interaction with automated roadblockers and bollards. Adding greater remote control, product data monitoring and functionality to your perimeter security products.

Available as an option with any of Heald's automated products, the Hydra system facilitates push button control of blockers and bollards, product health monitoring, status feedback, historical product usage data and much more.

Users can also control and monitor the status of products via a tablet app, mobile phone or PC.

Data is securely transmitted via ethernet, data bus or mobile network with the optional GSM module. This is enabled by utilising end to end bank level encryption or an air gap system.

Especially useful for large or complex installs where multiple units are operating in tandem, allowing for more customisable operation than any other system currently available and compatible with most existing Heald installations.

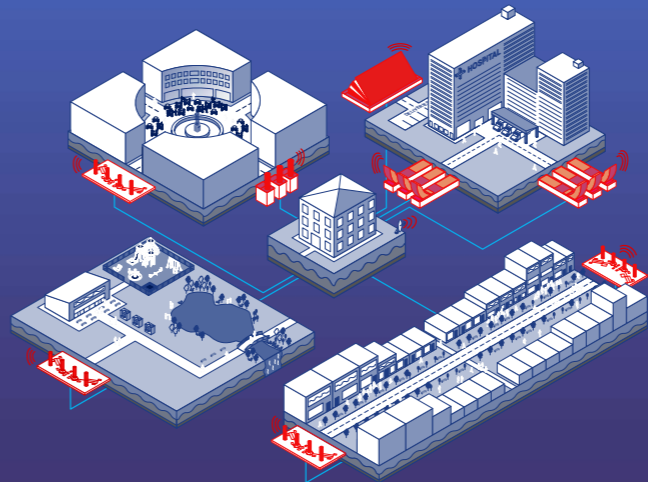
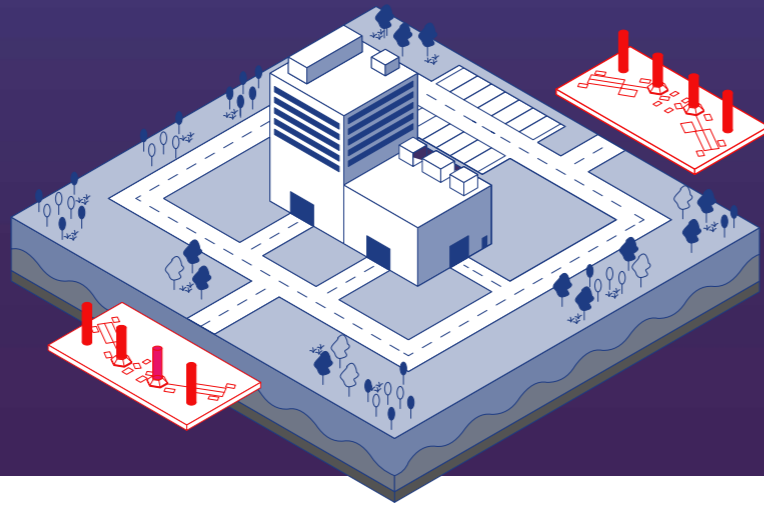

Three different tier systems have been designed to choose from; bronze, silver & gold; ranging in a variety of different functionalities, all of which are laid out below and in more detail in our Hydra Booklet.

The option to add selected functions to your chosen pack is also available upon request.

Function	Bronze	Silver	Gold
Heald Contact Information	/	/	/
Access Control Integration	/	/	/
Alarm Indication	/	/	/
Heald On-site Engineer Access	/	/	/
Heald Remote Engineer Access		/	/
Service Interval Information		/	/
Email Report Functionality		/	/
PDF Viewer		/	/
System Overview		/	/
Product Trends			/
Single Site - Multiple Product			/
Remote VNC			/
Multiple Site - Multiple Product			/
Data Recording and Output			/
10" Screen	/		/
15" Screen		/	/
21" Screen			/

INSTALLATION

Custom Design & Planning

We pride ourselves in the collaborative approach of our Engineering and Technical Departments. We work closely with architects, RSES Engineers, town planners, M&E engineers, and other designers from the very start of a project to expedite decision making and solve technical challenges in a timely fashion. We provide site surveys, online meetings, and detailed design workshops to mitigate risks and keep projects on schedule and budget.

Delivery & Installation

Customers can choose from full perimeter security installation, supply-to-site, or on-site supervision. Our skilled Installation Engineers—backed by our Office Team—ensure every detail is understood before arrival, enabling rapid, cost-efficient installation.

MAINTENANCE

For over 30 years we have supported a range of longstanding and loyal customers to ensure optimal performance of their perimeter security solutions to maximise product longevity.

We pride ourselves on our rapid response times and our expertise in bollard, Roadblocker and barrier maintenance giving you peace of mind that your site is secure 24/7, all year round.

We offer a swift response and full site support for all new and existing installations, in addition to a high level of service with qualified and experienced engineers.

SERVICING

Our promise is backed up by our compliance with ISO/TS0004:2018 Quality Management System Guidelines, and our customer service standards have been independently verified and granted the Platinum Award by Customer Surveys Ltd.

In addition we offer:

Highly trained staff, professional service, safety checks, custom tailored packages, detailed service reports, technical support, quick response times, 24/7 telephone service.

DISTRIBUTORS

Heald work with a network of global distribution partners, providing support across Europe, North America, Northern Africa, Middle East, South East Asia and Australia.

Our distributors receive continuous product training to ensure that they have the most up to date information about our full range of products. They are equipped with teams of approved installation and maintenance engineers, in addition to knowledgeable sales teams, to provide the same high quality turnkey service to all customers.

DISTRIBUTION

At Heald, we take pride in our strong, long-standing partnerships with trusted perimeter security experts in over 21 countries worldwide. These global relationships have enabled the successful installation of Heald's crash-tested hostile vehicle mitigation products at more than 1,500 sites around the world.

Export accounts for approximately 70% of all Heald's product sales, with installations at world renowned locations including the French Quarter in New Orleans, Australia's Gold Coast, Dubai Expo 2020, in addition to many high security governmental and military sites globally.



Each partner that works alongside Heald shares the same passion for our unique award-winning products and desire for excellent customer service.

To celebrate their contribution to the development of the company, Heald created the Distributor of the Year award. Starting in 2018 due to a record breaking sale from our partners in UAE, this award is presented yearly to the company with the highest product sales.

Heald are thankful to all of our distributors for their continued support and hard work.

If you are interested in joining our team of distributors, please contact Heald for more information.

At Heald, our mission is to provide solutions to make the world a safer place. This is rooted in our belief that through teamwork, dedication, innovation & experience we can provide the highest quality, sustainable security products to protect vulnerable locations & save lives.



HEALD®

+44 (0)1964 535858

sales@heald.uk.com

Heald Ltd,

Northfield, Atwick Road, Hornsea,

East Yorkshire, United Kingdom,

HU18 1EL



Heald Ltd



Heald Ltd



@healduk



Heald Ltd

