

SPACEPOD

The Spacepod is a highly configurable product which uses up to 50% less space than traditional bike storage.

The Spacepod offers 2 secure separate locking points and is an ideal solution where space is at a premium or where only wall space is available.



Product Name: MDPE Spacepod Panel.

Panel Material: Medium density polyethylene (MDPE), Black version is standard and is recycled and recyclable. All other colour versions are just recyclable.

Panel Thickness: 7-9mm**. Outer lower rim 20mm high. 60mm channel/track to cater for 99% of all standard European tyre width's. Rain water holes in base of every track.

Panel Finish: Dimpled effect with varying colour range.

Panel Weight: 15kg each.

Securing Arms Material: 25mm diameter 2.5mm thickness recycled grade Stainless Steel tube or 20mm Galvanised Solid rod (standard). Metal reinforcement plates added to arms.

Number of securing arms: 1 Upper arm and 1 lower arm. The securing arms provide the cyclist two individual locking points for both front wheel and frame plus back wheel and frame.

Top Plate Material: 5mm Stainless steel or galvanised steel.

Fixing Method for Securing Arms: Nyloc nut and Washer. All housed internally so no visible fixings.

Fixings Material: All standard Cyclepod fixings are Stainless steel. Ground anchors are nickel plated.

Ground Fixings Required: 16mm outer diameter shield anchor bolts drilled to a depth of 100mm max. 2 fixing bolts required per panel.

Ground Type Required: Solid level base required. Concrete, large slabs etc.

Product Code: CYC001.

Colour Options: Black (Recyclable) Red, Yellow, Royal Blue, Light Blue, Dark Green, Light Green, Grey and Stone effect available.

SPACEPOD DIMENSIONS

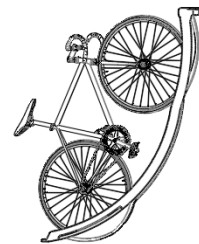
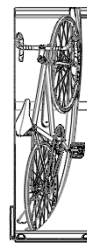
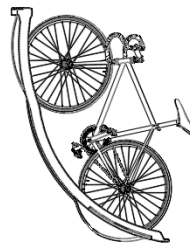
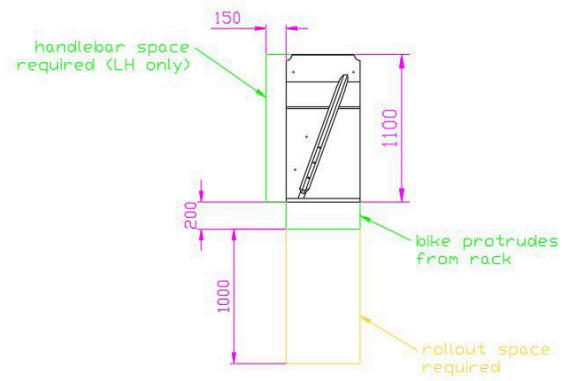
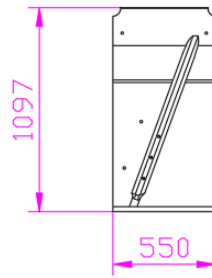

SPACEPOD LAYOUT EXAMPLES

