

## FACTORY FURNITURE



SOCA Lengthways Slat Seat (2.0m)

# Introduction

## Design

Design, shop drawings and development by Factory Furniture Ltd

## Manufacture

Factory Furniture manufactured components. Products are assembled in Factory workshops, checked and dispatched ready for installation. Replacement products or components should be ordered direct from Factory Furniture Ltd.

## Copyright

The design copyright for the product and drawing copyright remains the sole property of Factory Furniture Ltd.

## Timber

All timber used in Factory Furniture products is FSC® certified



# Contents

Spec Sheet	
SOCA Lengthways Slat Seat (2m) (Concrete Base)	... 3
SOCA Lengthways Slat Seat (2m) (Steel Base)	... 4
SOCA Lengthways Slat Seat (2m) (Illuminated Base)	... 5
Detailed Materials	... 6
Maintenance & Repair	... 7
Installation Instructions	
SOCA Lengthways Slat Seat (Concrete Base)	... 8
SOCA Lengthways Slat Seat (Steel Base)	... 9
SOCA Lengthways Slat Seat (Illuminated Base)	... 10
NBS Specifications	
SOCA Lengthways Slat Seat (Concrete Base)	... 11
SOCA Lengthways Slat Seat (Steel Base)	... 12
SOCA Lengthways Slat Seat (Illuminated Base)	... 13

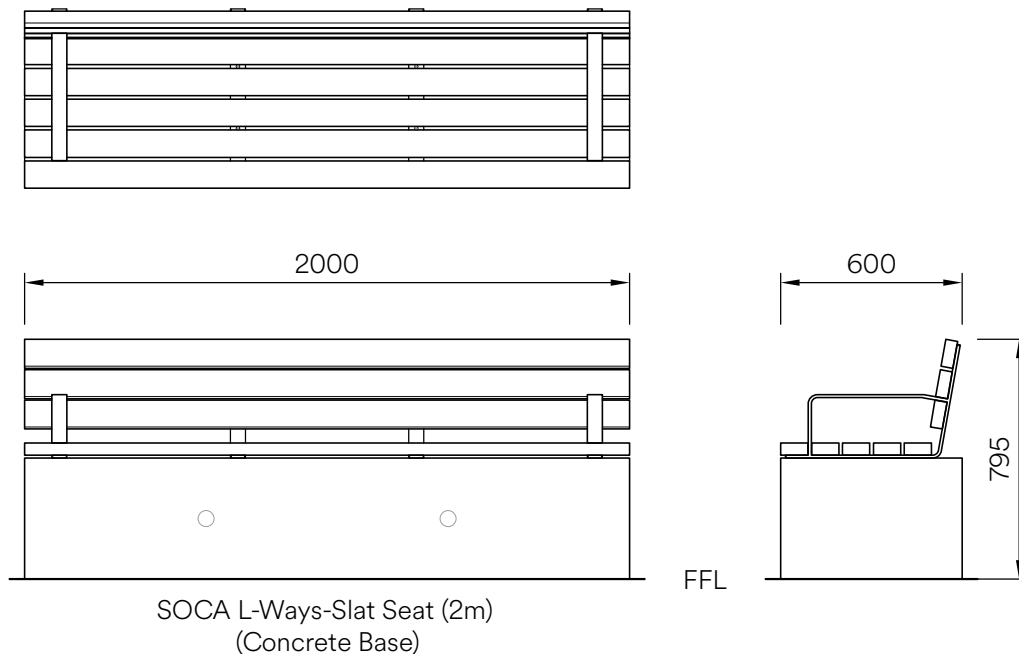

## Composition

Slats - FSC® certified timber (hardwood, softwood or modified timber options) with aluminium endcaps and spacers

Frame - Mild steel

Base - Concrete (various stone effects available)

## Finishes

Timber - Untreated sanded finish as standard (softwood options are tanalised after profiling)

Mild steel - Hot-dip galvanised (polyester powder-coat available (colour as per client's specification))

Concrete - Sealed (waterproofed and anti-graffiti)

## Dimensions

Metric L 2000mm | width 600mm | height 795mm

Imperial L 6' 6½" | width 1' 11½" | height 2' 7½"

## Approx weight

1186kg

## Foundation

1 no. pad 2100 x 700 x 300 mm in C20 concrete  
(recommendation only)

## Handling

Please observe health & safety lifting guidelines. A forklift or crane will be required for off-loading and positioning of this product \*\*Lifting eyes not supplied\*\*

## Maintenance

Depends on usage and position. All elements will require cleaning annually. Stainless steel and concrete require no maintenance.

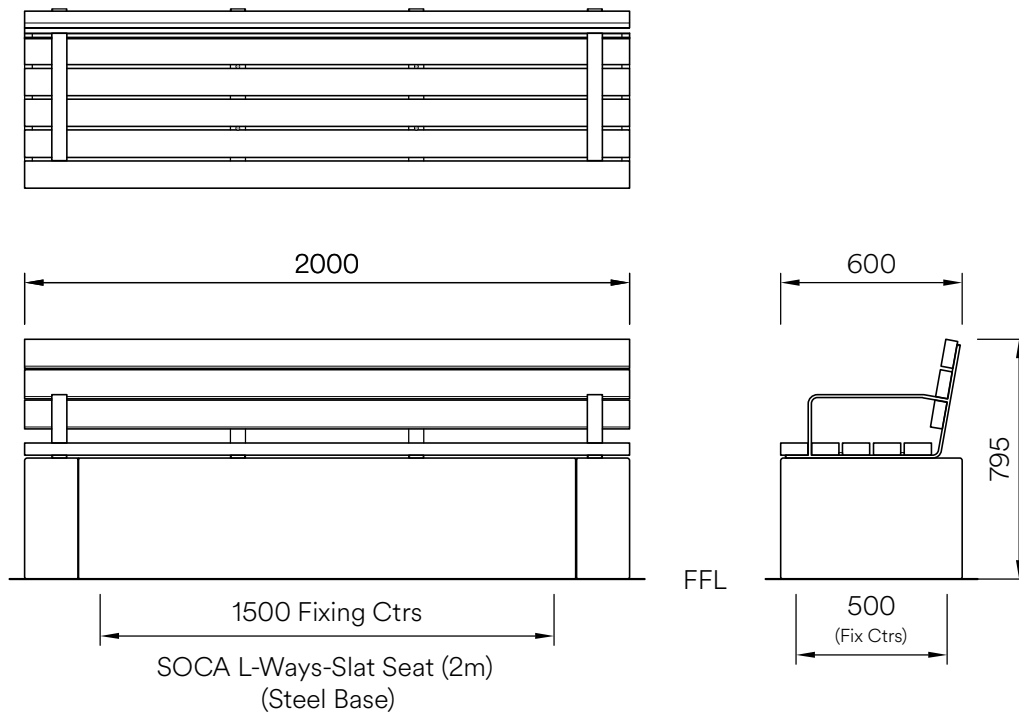

## Composition

Slats - FSC® certified timber (hardwood, softwood or modified timber options) with aluminium endcaps and spacers

Frame - Mild Steel

Base - Mild steel or Corten steel

## Finishes

Timber - Untreated sanded finish as standard (softwood options are tanalised after profiling)

Mild steel - Hot-dip galvanised (polyester powder-coat available (colour as per client's specification))

Corten steel - Untreated as standard

## Dimensions

Metric L 2000mm | width 600mm | height 795mm

Imperial L 6' 6½" | width 1' 11½" | height 2' 7½"

## Approx weight

202kg

## Foundation

2 no. pad 400 x 700 x 400mm in C20 concrete  
(recommendation only)

## Handling

Please observe health & safety lifting guidelines. A forklift or crane will be required for off-loading and positioning of this product.

## Maintenance

Depends on usage and position. All elements will require cleaning annually. Stainless steel and corten require no maintenance.

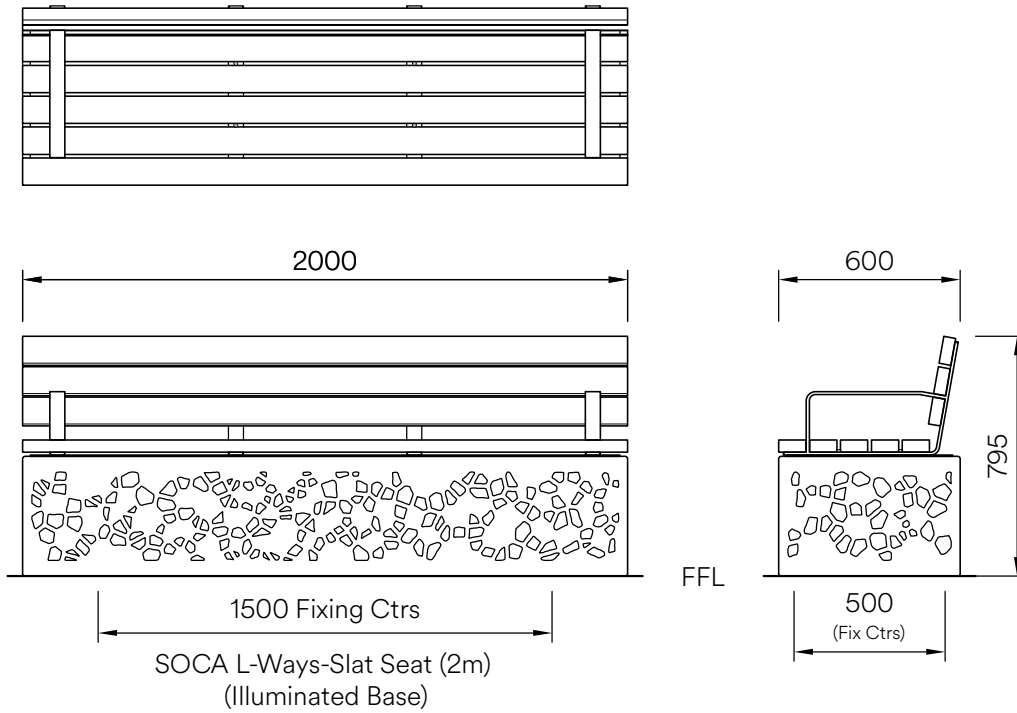

## Composition

Slats - FSC® certified timber (hardwood, softwood or modified timber options) with aluminium endcaps and spacers

Frame - Mild Steel

Base - Mild steel or Corten steel

## Finishes

Timber - Untreated sanded finish as standard (softwood options are tanalised after profiling)

Mild steel - Hot-dip galvanised (polyester powder-coat available (colour as per client's specification))

Corten steel - Untreated as standard

## Dimensions

Metric L 2000mm | width 600mm | height 795mm

Imperial L 6' 6½" | width 1' 11½" | height 2' 7½"

## Approx weight

203kg

## Foundation

2 no. pad 400 x 700 x 400mm in C20 concrete  
(recommendation only)

## Handling

Please observe health & safety lifting guidelines. A forklift or crane will be required for off-loading and positioning of this product.

## Maintenance

Depends on usage and position. All elements will require cleaning annually. Stainless steel and corten require no maintenance.

# Detailed Material & Finish Specifications

## Seat Slat Assembly

- Seat and backrest slats are manufactured from FSC® certified timber (hardwood, softwood or modified timber options) and are profiled with a sanded finish. Hardwood left untreated (natural) as standard. Soft wood options are tanalised to improve life span.
- Seat slats assembled using aluminium endcaps, spacers and concealed zinc-coated mild steel tie rods.
- Sub-frame (incl. armrest) is manufactured from hot-dip galvanised mild steel (polyester powder coat available (colour as per customer specification))

## Concrete Base Option

- Manufactured from concrete (different stone effects available). Surface is sealed to make it water repellent. Galvanised steel internal reinforcement.
- Seat slat assembly screwed to concrete base
- 4 no. lifting sockets included (RD20 knuckle thread Din 405) \*\*Lifting eyes not supplied\*\*

## Steel Base Option

- Manufactured from mild steel or corten steel (all welded construction). Removable slat assembly bolted to base.
- Corten bases left untreated. Mild steel bases are hot-dip galvanised with the option for a polyester powder coated finish (colour as per customer specification)
- Base anchored to ground using 4 no. zinc-coated M10 x 75mm sleeve anchors.

## Illuminated Base Option

- Manufactured from mild steel or corten steel (all welded construction). Removable slat assembly bolted to base.
- Corten bases left untreated. Mild steel bases are hot-dip galvanised with the option for a polyester powder coated finish (colour as per customer specification)
- Base anchored to ground using 4 no. zinc-coated M10 x 75mm sleeve anchors.
- LED rope light (warm white as standard) mounted within base provides night-time illumination on all sides through removable white frosted polycarbonate diffuser panels mounted behind walls of base.

# General Maintenance (Recommended Schedule & Guidelines)

## Daily/Weekly/Monthly (or as adopted)

Visual checks of seat top, back and base - check all items for superficial or physical damage.

## Three Monthly

Clean all items as detailed below check all fixings are seated correctly; inspect timber for serious damage and splinters.

## Six Monthly

Secure all fixings; full clean as detailed below; check that seat is firmly secured to the ground

# Specific Maintenance Details

## FSC Timber

Clean with a stiff brush once per year, especially in more exposed locations, in order to prevent a verdigris type build up on the timber surface. Ideally this should be completed in early spring. During the cleaning stage, all exposed timber surfaces should be inspected for splits and splinters. Any splinters and graffiti should be removed and the surface sanded with 100 grit sandpaper in order to remove any uneven / sharp edges or surfaces.

During the first few months after installation the tannin naturally occurring in the timber may leach out and cause a brown staining on the bases. This may be removed with a light solution of household bleach and water.

## Polyester Powder Coated & Galvanised

For general cleaning using a damp cloth and warm soapy water only. Scourers and abrasive cleaners are NOT suitable for this type of finish and may damage it. Before using any cleaning agents to remove graffiti etc. try on a small, inconspicuous area first to avoid causing more unsightly damage.

## Corten Steel & Stainless Steel (polished stainless steel only)

Clean as required, but at least every three months. For stainless use a stainless steel polish and a lint free cloth. To remove ground in dirt, a stainless steel finishing pad may be required.

## Concrete (also granite)

Clean with a stiff brush once per year, especially in more exposed locations, in order to prevent a verdigris type build up on the surface. Ideally, this should be completed in early spring.

# Repairs

## FSC Timber

For light damage, please see section on specific maintenance details above. For instances of heavy damage, the timber item should be replaced. Please order against the part number reference in the reordering section towards the end of this manual.

## Polyester Powder Coated & Galvanised Surfaces

For light damage (scratches, chips etc.) repair using touch-up paint to match original colour (available from Factory Furniture Ltd). Paint application should be carried out in accordance with approved methods detailed by the paint manufacturer. Please note that it is advisable to use professional painters to achieve best results when touching up larger areas. Products for respraying larger areas are available from Factory Furniture Ltd.

## Corten Steel

There is no need to repair light damage (scratches, chips etc.) to the rust coloured layer on the surface of the Corten steel. This layer will naturally reform within a short period of time in an external environment.

## Stainless Steel

Light damage (surface scratches etc.) can be removed using an emery pad (240 grit) and freeing oil such as 'WD40'. Care should be taken to follow the direction of the brushing grain. It is recommended that a trial repair be carried out on an unimportant surface first. No corrosive cleaners or other abrasives should be used. Any contamination, particularly carbon steel scuffs from vehicles, should be quickly removed to avoid corrosion.

## Heavy Damage

In the event of serious damage to any component, replacements should be ordered from Factory Furniture Ltd. Should further assistance be required (or if the product needs to be disassembled for any reason), please contact Factory Furniture for detailed technical advice.

# Installation Instructions

ALL INSTALLATION WORKS TO BE CARRIED OUT BY COMPETENT PERSONNEL - INSTALL AS COMPLETE UNIT

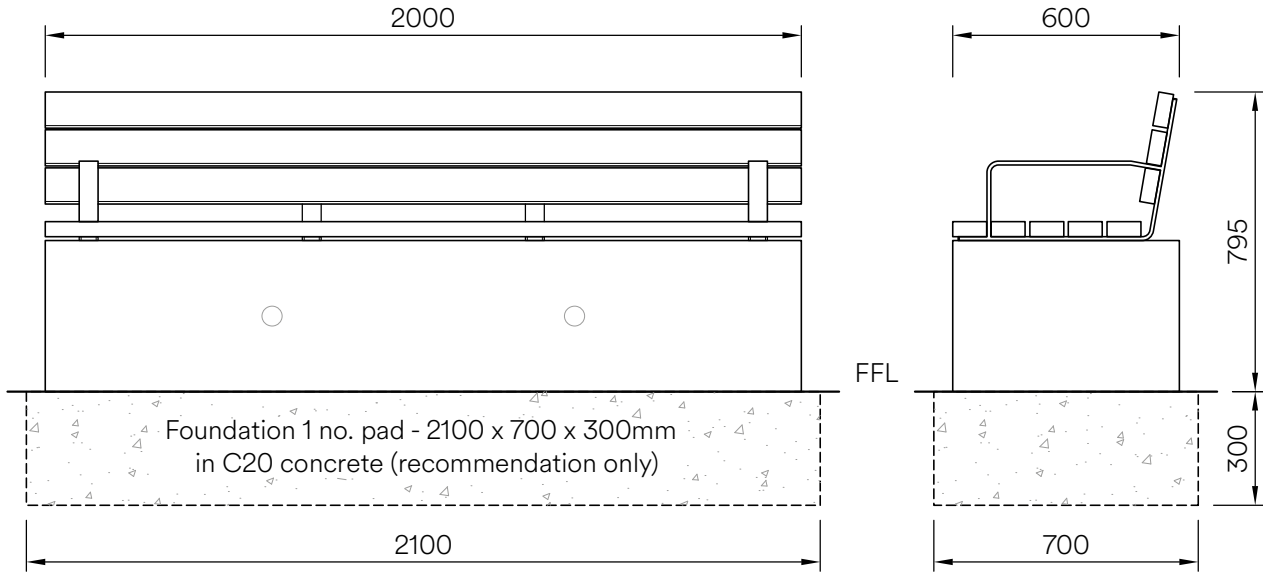

## Soca Seat - Concrete Base

1. Install suitable foundation pad (see illustration) approx 50mm larger than footprint of bench on all sides. Set top face at ground level
2. Position seat centrally onto foundation pad - 4 no. lifting sockets included to aid lifting and positioning (RD20 knuckle thread Din 405) **\*\*Lifting eyes not supplied\*\***
3. Check level and screw in lifting eye dust covers.

### IMPORTANT NOTE:

Ensure that stainless steel is protected during site cutting of stone – contamination from disc cutters will produce corrosion on stainless steel components.

# Installation Instructions

ALL INSTALLATION WORKS TO BE CARRIED OUT BY COMPETENT PERSONNEL - INSTALL AS COMPLETE UNIT

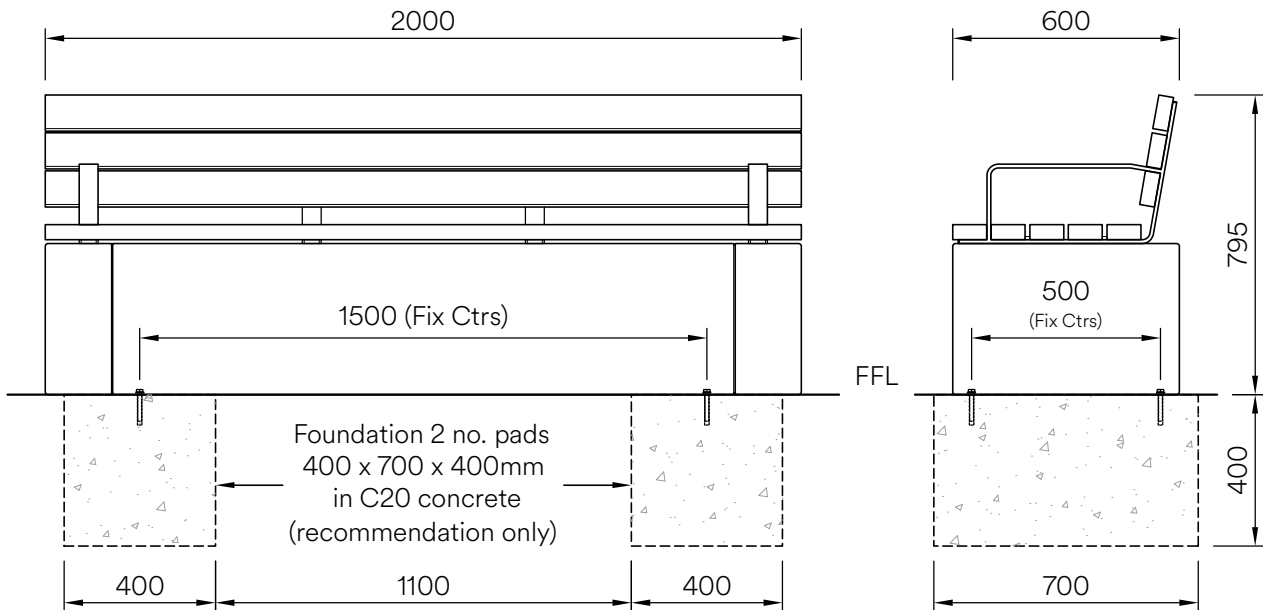

## Soca Seat - Steel Base

1. Install suitable foundation pads (see illustration) with top faces at ground level
2. If necessary remove slat assembly (8 no. bolts visible between slats) and remove end sections of base to access base fixing holes in mid section. To detach end sections, unscrew M6 csk bolts on top, slide section vertically up 15mm to release locator pins and then pull away from mid section.
3. Position mid section so that it's central on foundation pads then mark hole positions onto pads
4. Remove the base; drill holes  $\text{\O}12\text{mm}$  x 75mm deep (or as bolt manufacturer's recommendations)
5. Clear debris from holes
6. Reposition base and fix to foundation pads using 4 no. zinc-coated M10 x 75mm sleeve anchors tightened to 50Nm (or as per manufacturer's instruction). Ensure base remains level during fixing process.
7. Replace end sections and slat assembly
8. Check level & re-instate ground level if required

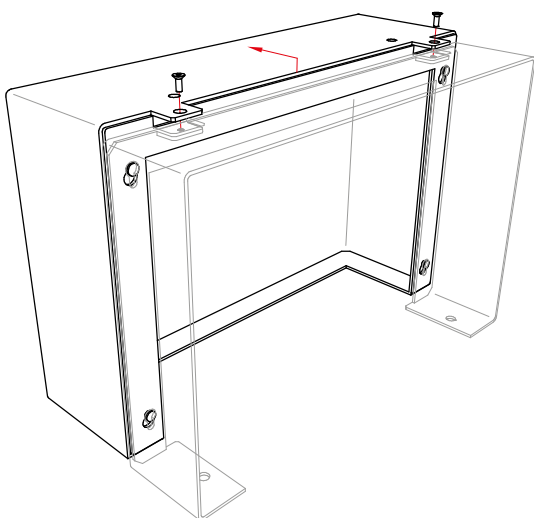

End Section Detachment

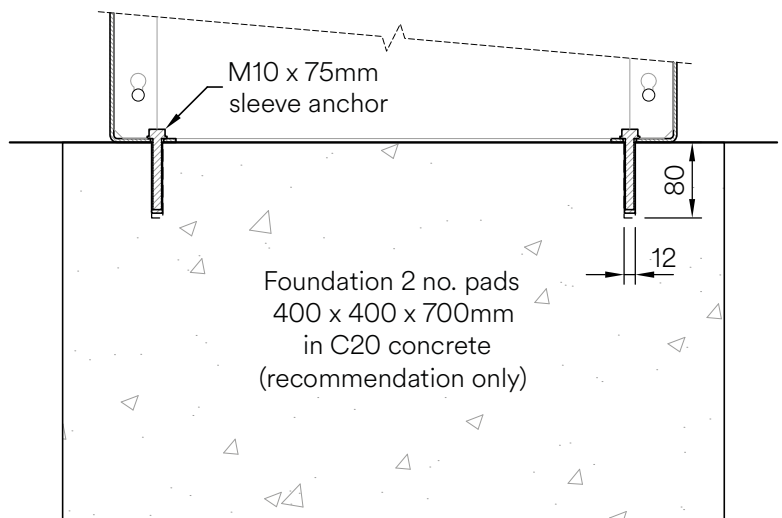

Base Fixing Detail

# Installation Instructions

ALL INSTALLATION WORKS TO BE CARRIED OUT BY COMPETENT PERSONNEL - INSTALL AS COMPLETE UNIT

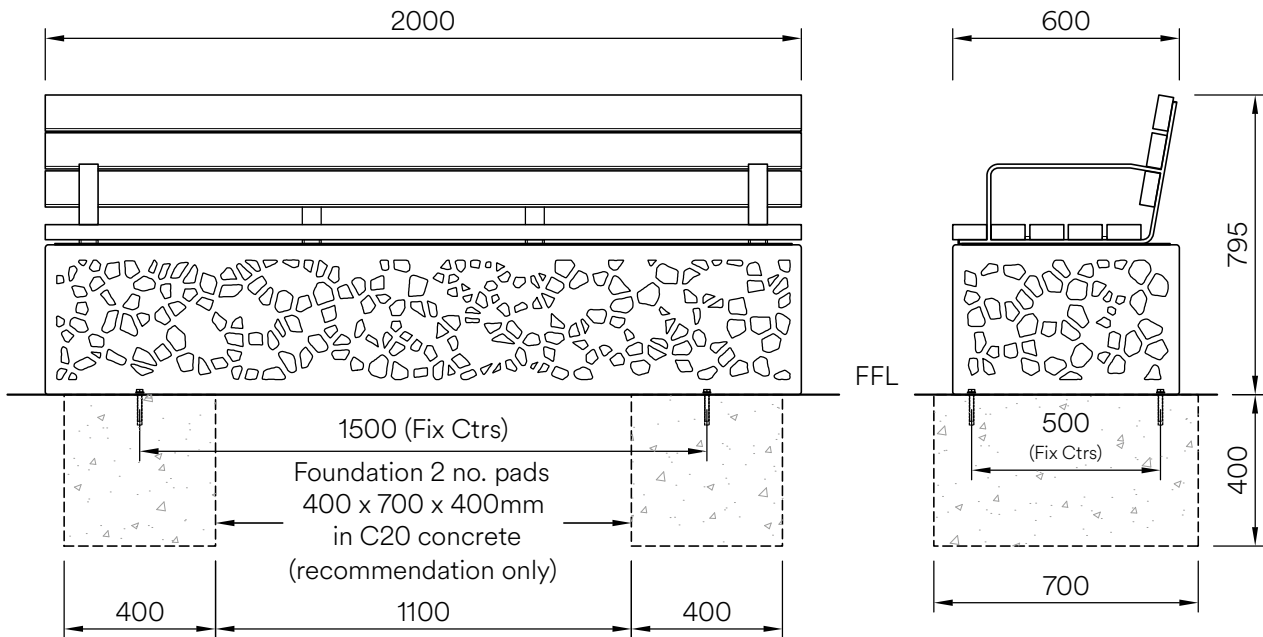

## Soca Seat - Illuminated Base

1. Install suitable foundation pads (see illustration) with top faces at ground level
2. If necessary remove slat assembly (8 no. bolts visible between slats) to access base fixing holes within base
3. Position base so that it's central on foundation pads then mark hole positions onto pads
4. Remove the base; drill holes  $\text{\O}12\text{mm}$  x 75mm deep (or as bolt manufacturer's recommendations)
5. Clear debris from holes
6. Reposition base and fix to foundation pads using 4 no. zinc-coated M10 x 75mm sleeve anchors tightened to 50Nm (or as per manufacturer's instruction). Ensure bench remains level during fixing process
7. Check level & re-instate ground level if required
8. At this stage LED lighting in base can be connected to the supply by a suitably qualified electrician
9. Re-position and bolt down slat assembly

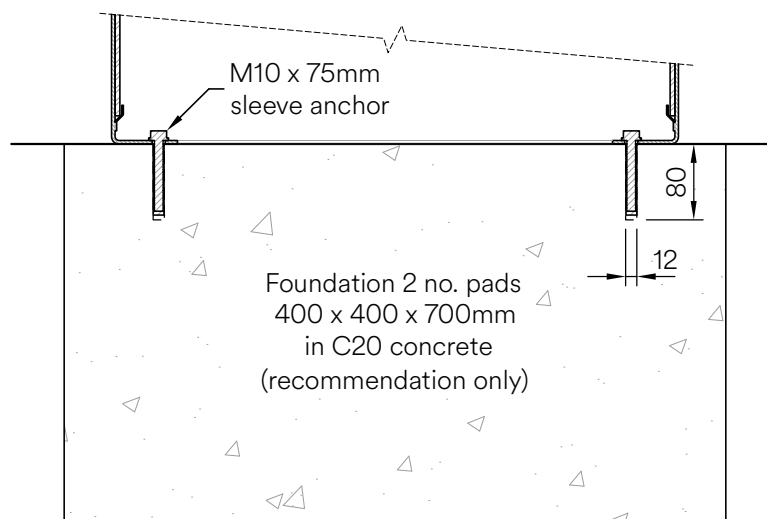

Base Fixing Detail

# NBS Specification Data

## PRODUCT REFERENCE – FF1021 – SOCA LENGTHWAYS SLAT SEAT (CONCRETE BASE)

Description Seat with timber slats, mild steel frame and concrete base  
Uniclass 2015 Category Pr\_40\_30\_29\_84 Street and site benches  
Design as per drawing: FF1021\_5

### MANUFACTURER

Name Factory Furniture Ltd  
Address Unit 5 Pioneer Road, Faringdon, Oxfordshire, SN7 7BU  
Website [www.factoryfurniture.co.uk](http://www.factoryfurniture.co.uk)  
Telephone +44 (0)1367 242731

### MATERIAL

Slats FSC® certified timber (hardwood, softwood or modified timber options)  
Frame Mild steel  
Base Concrete

### FINISH

Timber Sanded natural finish as standard (softwood options are tanalised after profiling)  
Mild steel Hot-dip galvanised (option for polyester powder coat)  
Concrete Smoothed and sealed

### SIZE

2000mm x 600mm x 795mm (LxWxH)  
3000mm x 600mm x 795mm (LxWxH)

### FIXING

Free standing



