



CAVALIER™ NOTICE BOARD

Our **Cavalier™** notice boards combine classic design with modern durability. Built to withstand the elements, they offer long-lasting performance in outdoor and high-traffic areas. Available in single or double door options, each board features lockable doors to keep notices secure and protected.

The timeless, understated appearance complements heritage and civic settings, while the practical construction ensures easy maintenance and clear presentation. A reliable choice for displaying important information with both style and strength.

Product features

- Stainless steel construction
- Can be supplied with or without a header board
- Robust stainless steel locks
- Gas struts to support doors when open
- Tough 4mm clear polycarbonate window
- Magnetic back board – magnets included
- Vent holes to minimise condensation
- Powdercoat finish to standard colour
- Standard sizes A2, A1 and A0
- 1 year manufacturer's warranty

Specification applies to the standard product. Our range of options usually allow us to accommodate any differences you may require. Please contact us and we will be happy to support you in developing this specification to meet your requirements.

Option delete/ update as appropriate

Manufacturer: Fitzpatrick Woolmer,
Unit 7 Lakeside Park, Neptune Close,
Rochester, Kent, ME2 4LT.

Tel: 01634 711 771

Email: info@fwdp.co.uk

Metal: Stainless steel

Grade: 304

Metal: Aluminium

Grade: 1050

Finish: Powdercoat to BS EN 12206:2021 Part 1

Colour: RAL 9005 Black

Fixings: Stainless steel

Type: Security

Weight: 86kg

Installation: Posts extend 600mm below ground level

Guarantee: One year manufacturer's warranty

Note:
All dimensions are indicative only.
Footing details are subject to
soil conditions and structural
engineers recommendations.

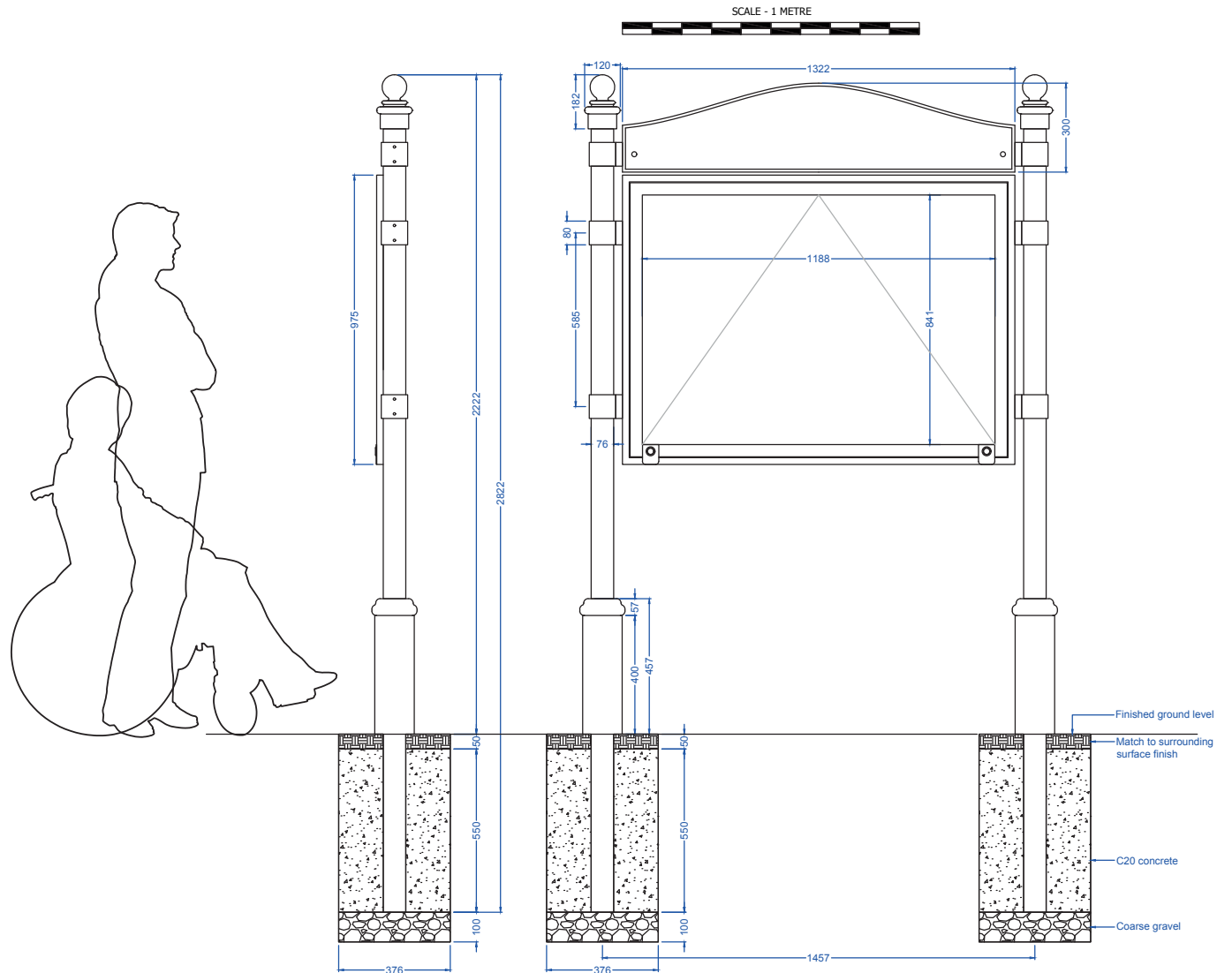

Specification applies to the standard product. Our range of options usually allow us to accommodate any differences you may require. Please contact us and we will be happy to support you in developing this specification to meet your requirements.

Option delete/ update as appropriate

Manufacturer: Fitzpatrick Woolmer,
Unit 7 Lakeside Park, Neptune Close,
Rochester, Kent, ME2 4LT.

Tel: 01634 711 771

Email: info@fwdp.co.uk

Metal: Stainless steel

Grade: 304

Metal: Aluminium

Grade: 1050

Finish: Powdercoat to BS EN 12206:2021 Part 1

Colour: RAL 9005 Black

Fixings: Stainless steel

Type: Security

Weight: 93kg

Installation: Posts extend 600mm below ground level

Guarantee: One year manufacturer's warranty

Note:
All dimensions are indicative only.
Footing details are subject to
soil conditions and structural
engineers recommendations.

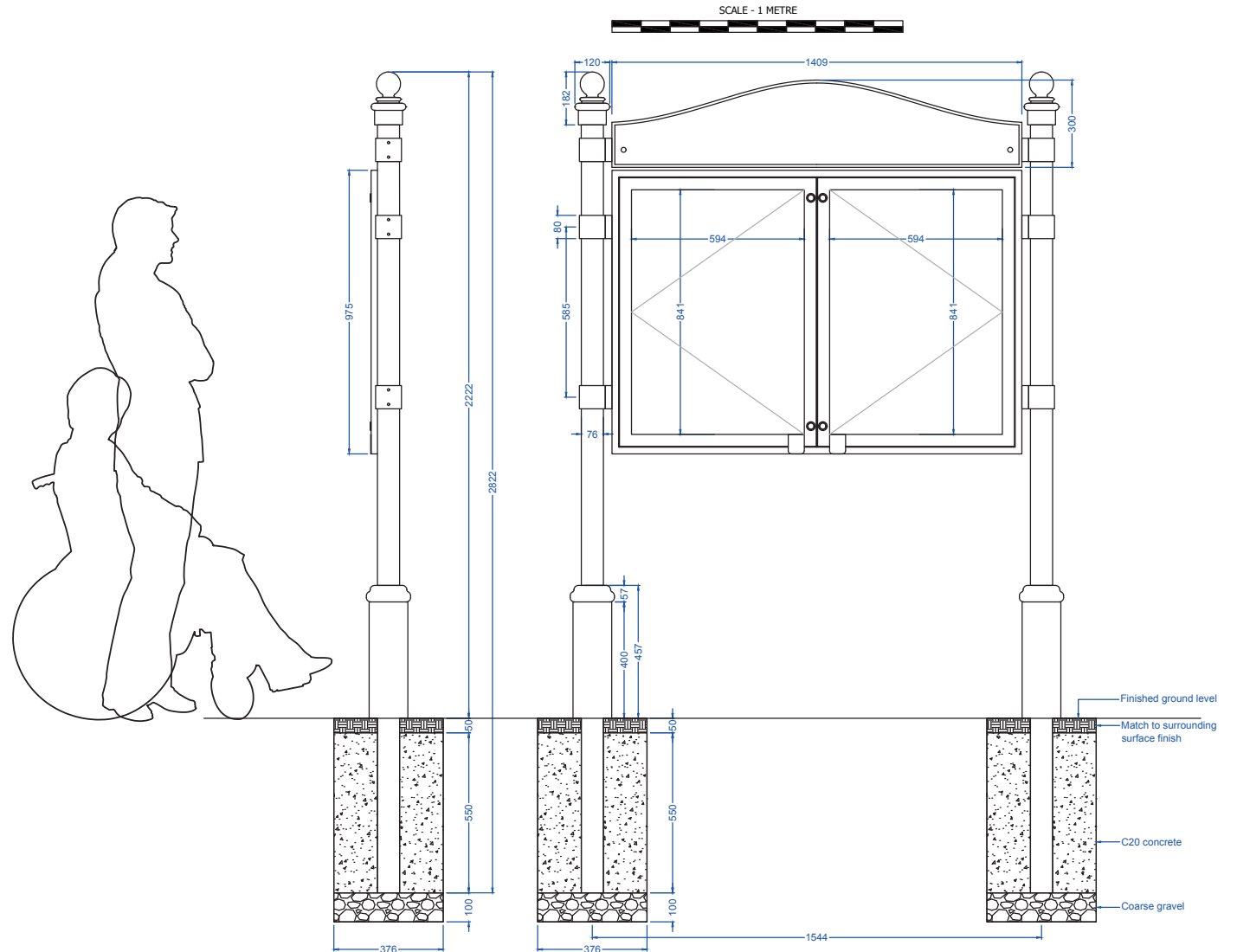

Specification applies to the standard product.
Our range of options usually allow us to accommodate any differences you may require.
Please contact us and we will be happy to support you in developing this specification to meet your requirements.

Option delete/ update as appropriate

Manufacturer: Fitzpatrick Woolmer,
Unit 7 Lakeside Park, Neptune Close,
Rochester, Kent, ME2 4LT.

Tel: 01634 711 771

Email: info@fwdp.co.uk

Metal: Stainless steel

Grade: 304

Finish: Powdercoat to BS EN 12206:2021 Part 1

Colour: RAL 9005 Black

Fixings: Stainless steel

Type: Security

Weight: 61kg

Installation: Posts extend 600mm below ground level

Guarantee: One year manufacturer's warranty

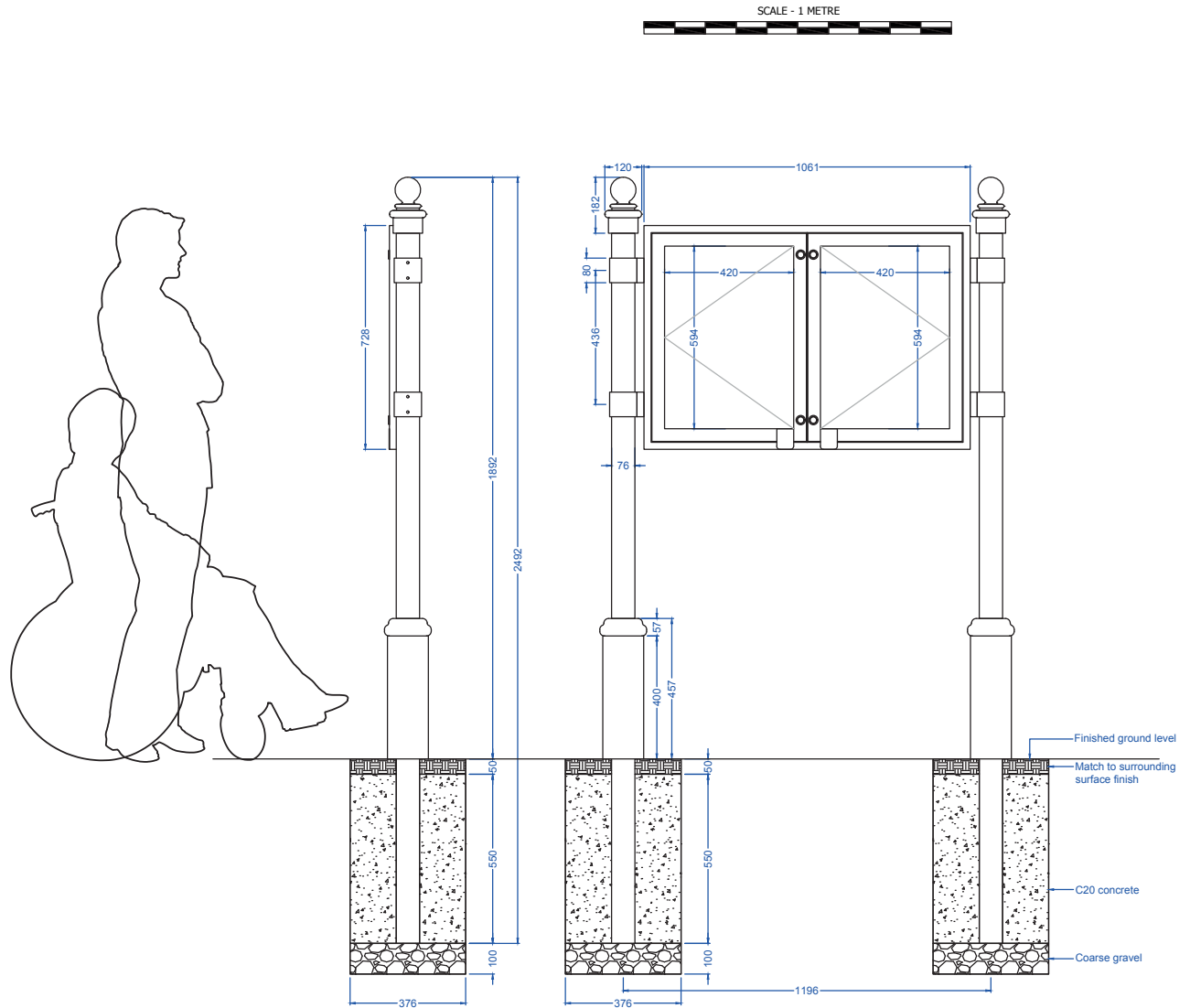

Note:
All dimensions are indicative only.
Footing details are subject to
soil conditions and structural
engineers recommendations.

Specification applies to the standard product.
Our range of options usually allow us to accommodate any differences you may require.
Please contact us and we will be happy to support you in developing this specification to meet your requirements.

Option delete/ update as appropriate

Manufacturer: Fitzpatrick Woolmer,
Unit 7 Lakeside Park, Neptune Close,
Rochester, Kent, ME2 4LT.
Tel: 01634 711 771
Email: info@fwdp.co.uk

Metal: Stainless steel

Grade: 304

Finish: Powdercoat to BS EN 12206:2021 Part 1

Colour: RAL 9005 Black

Fixings: Stainless steel

Type: Security

Weight: 47kg

Installation: Posts extend 600mm below ground level

Guarantee: One year manufacturer's warranty

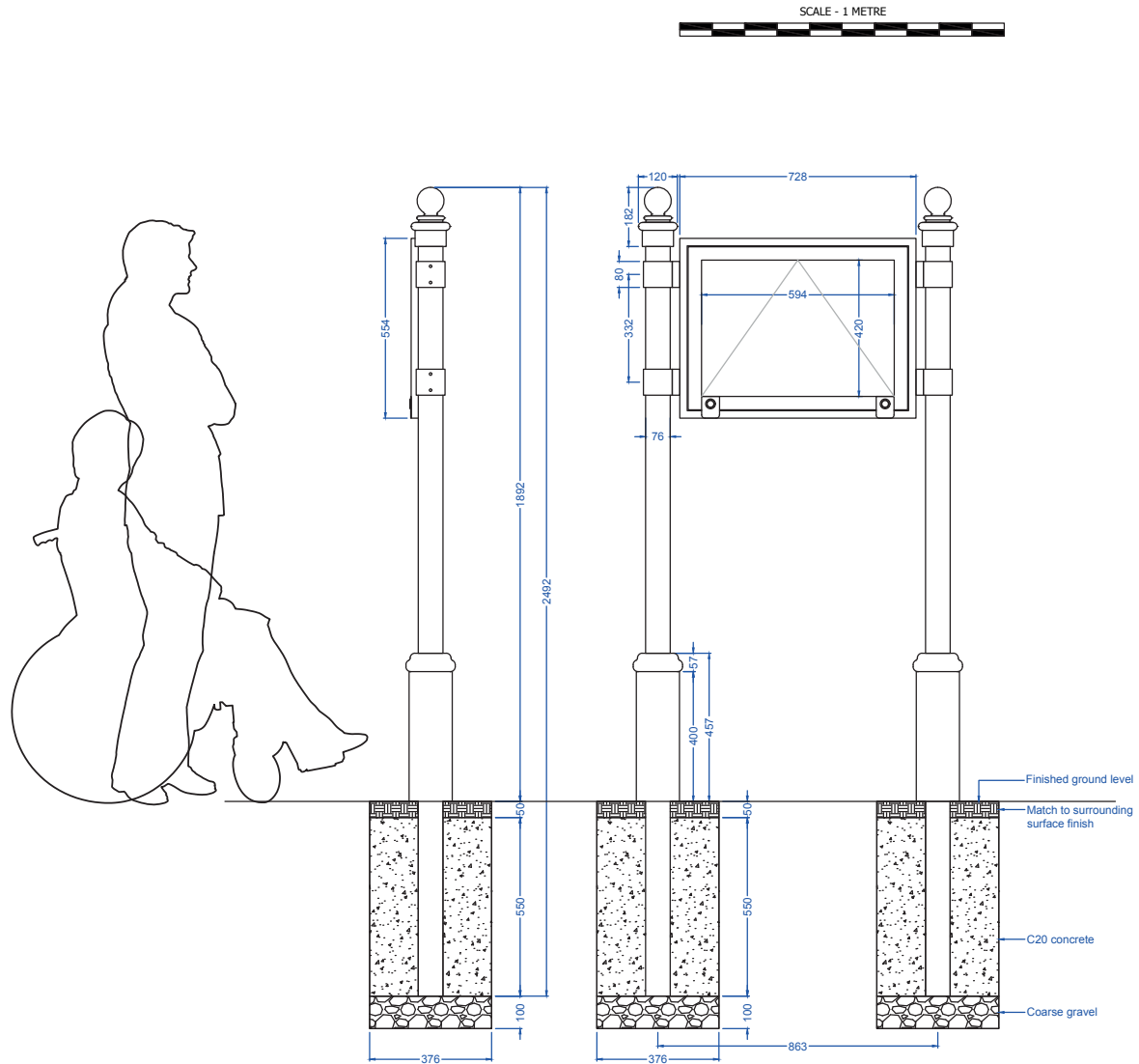

Note:
All dimensions are indicative only.
Footing details are subject to
soil conditions and structural
engineers recommendations.

Specification applies to the standard product. Our range of options usually allow us to accommodate any differences you may require. Please contact us and we will be happy to support you in developing this specification to meet your requirements.

Option delete/ update as appropriate

Manufacturer: Fitzpatrick Woolmer,
Unit 7 Lakeside Park, Neptune Close,
Rochester, Kent, ME2 4LT.
Tel: 01634 711 771
Email: info@fwdp.co.uk

Metal: Stainless steel

Grade: 304

Metal: Aluminium

Grade: 1050

Finish: Powdercoat to BS EN 12206:2021 Part 1

Colour: RAL 9005 Black

Fixings: Stainless steel

Type: Security

Weight: 56kg

Installation: Posts extend 600mm below ground level

Guarantee: One year manufacturer's warranty

Note:
All dimensions are indicative only.
Footing details are subject to
soil conditions and structural
engineers recommendations.

