

Shropshire Planter & Bench

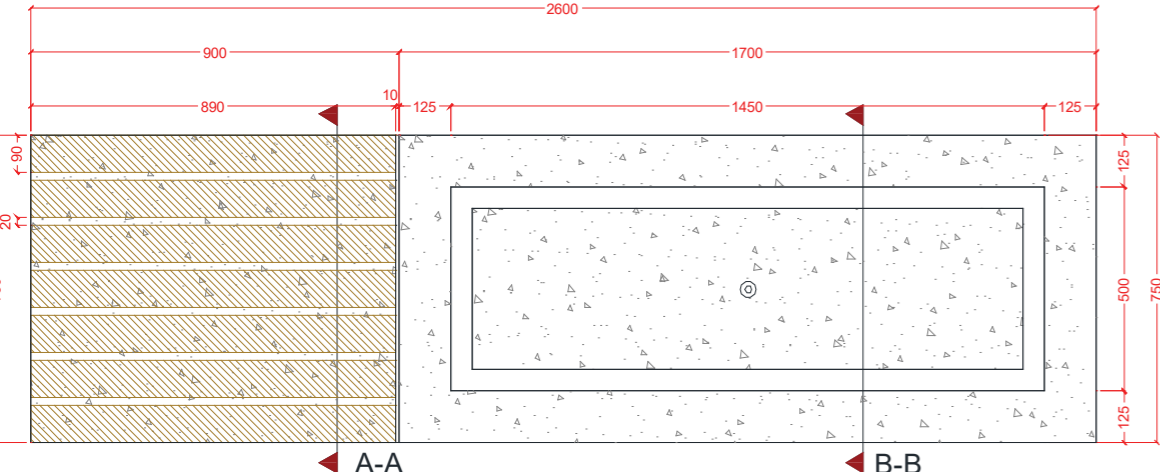

- PLANTER BENCH
- 750MM (W) X 450MM (H) 2600 (L)
- 5 NO. 90MM (W) X 46MM (H) CUMARU HARDWOOD SLATS, 20MM SPACING
- 2 NO. 90MM (W) X 90MM (H) CUMARU HARDWOOD SLAT, CUT TO FIT SHAPE, 20MM SPACING
- 1 NO. 10MM THICK STAINLESS STEEL BRACKET 80MM (W) X 34MM (H) X 658MM (L)
- 10MM CHAMFER TO EDGES
- 10MM SPACE FROM WOOD TO CONCRETE

Detail 1: Plan of Planter & Bench

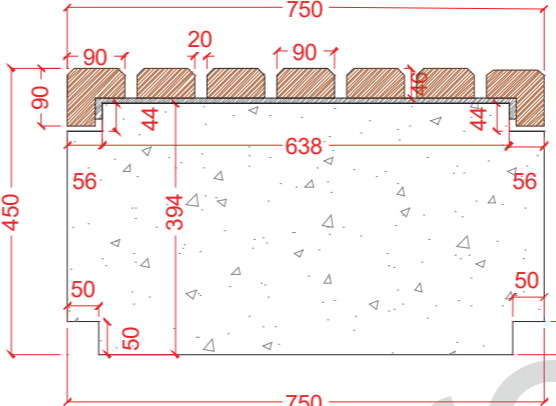

- PLANTER BENCH VIEW A-A
- 750MM (W) X 450MM (H) 2600 (L)
- 5 NO. 90MM (W) X 46MM (H) CUMARU HARDWOOD SLATS, 20MM SPACING
- 2 NO. 90MM (W) X 90MM (H) CUMARU HARDWOOD SLAT, CUT TO FIT SHAPE, 20MM SPACING
- 1 NO. 10MM THICK STAINLESS STEEL BRACKET 80MM (W) X 34MM (H) X 658MM (L)
- 10MM CHAMFER TO EDGES

Detail 2: Profile A-A

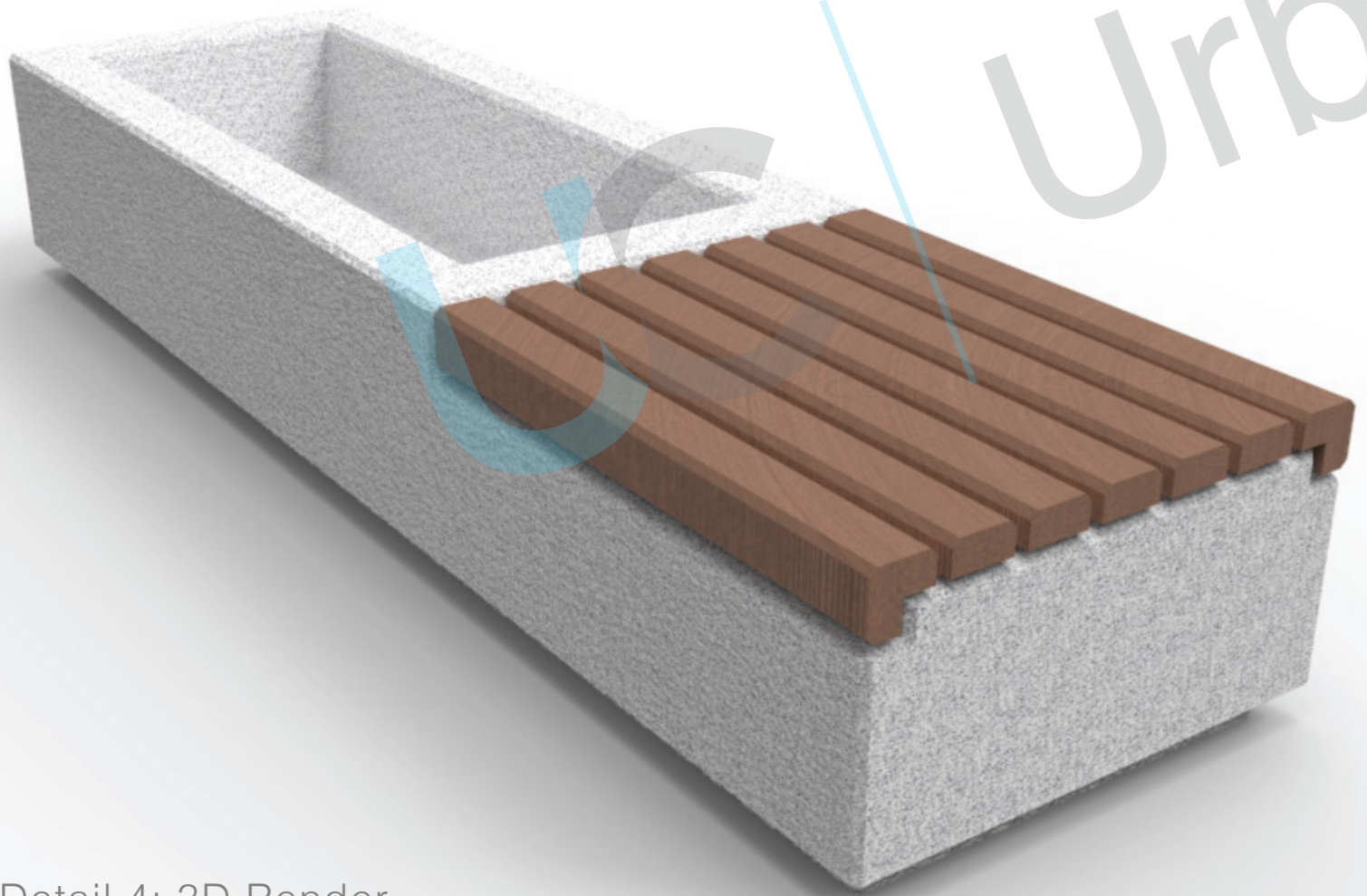

Detail 4: 3D Render

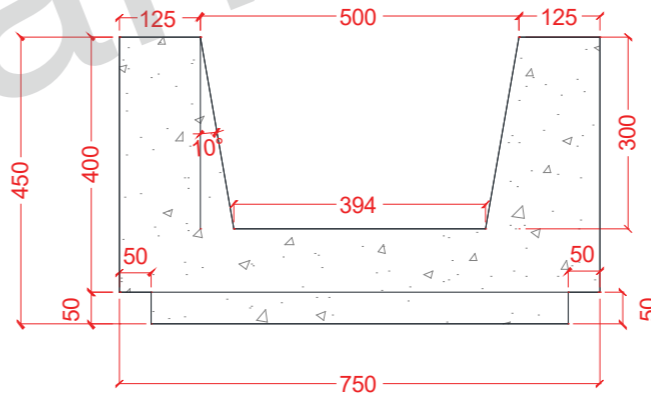

- PLANTER BENCH VIEW B-B
- 750MM (W) X 450MM (H) 2600 (L)
- 10MM CHAMFER TO EDGES
- 500MM (W) X 300MM (H) X 1450MM (L) VOID TO CREATE PLANTER
- 10° SLOPE ON ALL SIDES OF VOID FOR EASY REMOVAL

Detail 3: Profile B-B

