

Mud Kitchen with hob: CP-MUD

Mud Kitchens the opportunity to make a mess outside using a selection of natural 'ingredients' such as water, sand, stones, and mud.

Designed as two separate units each has an upper shelf, and shelves underneath for extra storage. This unit has a hob with four rings.

All the units are sturdy, built to last and fully weather-proofed.

Worktops are 65cm high and the standard unit length is 1.2m long.

Designs can be modified to suit specific requirements.

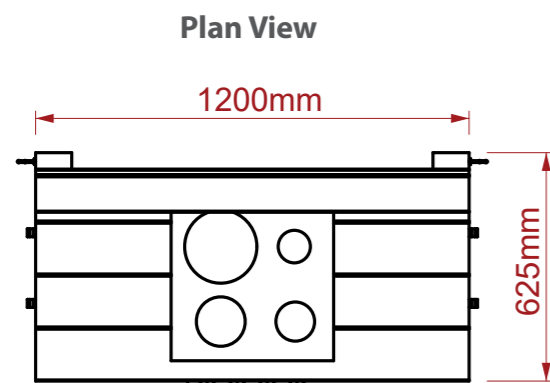

Front View

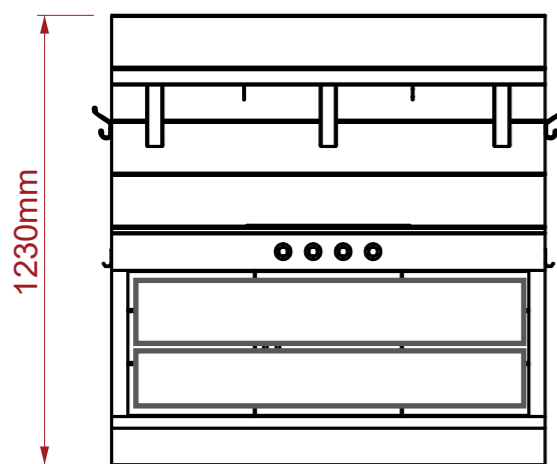

Side View

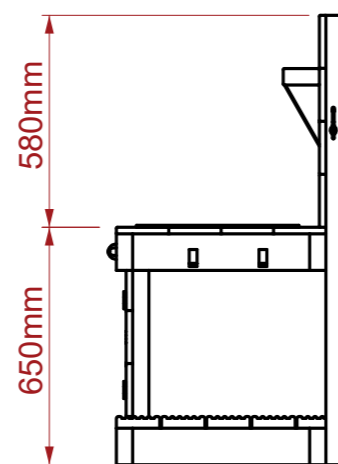

Specification:

Pressure treated timber with non-arsenic preservative, impregnated with wax.

Stainless Steel Fixtures and fittings.

(Note: Pots & Pans Not Included)

Product Specification:

Dimensions: L: 1.20m W: 0.63m H: 1.23m
Age Range: 3+ years
Play Type: Active
Free Fall Height: NA
Free Space Required: L: 1.20m W: 0.63m

Safety Surfacing Area: NA
Assembly: Installation Required
Mass of Heaviest Part: kg
Dimensions of Largest Part: L: 1.20m W: 0.63m H: 1.23m
Conformity to EN1176: Yes