

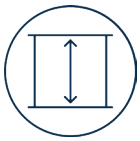

The Hoardfast range is a **quick-to-install, modular, free-standing** or **floor-to-ceiling** (up to 5m) internal partitioning and screening system that can be used as a temporary screen, permanent partition wall or to create internal rooms.

It is available in a **range of panel, support** and **stability options** to suit your environment and business needs.



Floor-To-Ceiling or Free-Standing

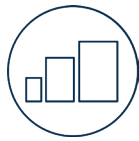

Range of Panel Types



Quick Modular Installation



Choose Self or Service Installation



Hire or Purchase Options



Express Delivery



Features and Benefits

Modular ready to install system	<ul style="list-style-type: none"> • Quick-to-install for minimal disruption to business schedules • Available for self-installation or installation by Westgate • Easy to configure as required (can be cut down easily) • Create temporary or semi-permanent partitions, screens and rooms
Sustainable product that can be reused	<ul style="list-style-type: none"> • Install and demount the product multiple times giving medium and long-term savings • Reduces waste and environmental impact on construction projects • Made from 85% recycled plastic, and relocatable/reusable
Express delivery from large UK stock	<ul style="list-style-type: none"> • Get items to site quickly to prevent delays
Hire or purchase option	<ul style="list-style-type: none"> • Pricing to suit your budget and project requirements • No storage requirements on paused or short projects

Installation

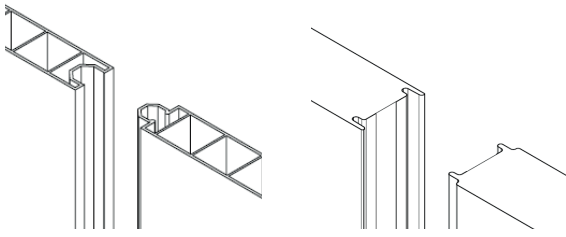

Tongue and groove system for quick and easy installation.

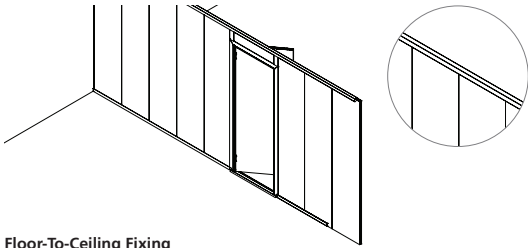

Floor-To-Ceiling Fixing
U-Channel Top and Bottom

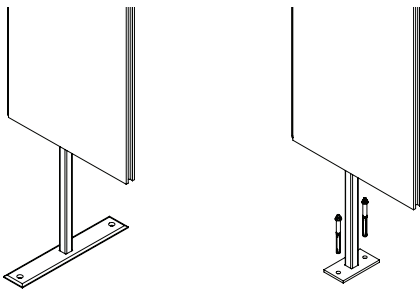

Free-Standing
Equal

Free-Standing
Bolt Down

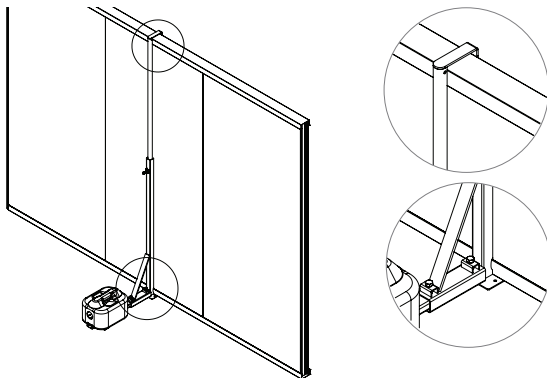

Free-Standing
Universal Support

Floor-to-ceiling or free-standing support options with high stability support available.

This fact sheet is for illustrative purposes only and based on the latest information at the time of print. Installation methods may vary depending on specific project requirements. Westgate Global reserve the right to make changes at any time without notice.

J230-WFD-PFS-HF-I-260924 © Westgate Global Ltd

Technical Specifications

Material Composite	uPVC hollow flute or steel faced with either fire rated PIR foam or mineral wool filled
Panel Fire Rating	uPVC hollow flute: BS476 Part 7 Class 1 (Spread of Flame) and EN13501-1 C s3 d0 (35mm profile only) Steel fire rated PIR foam filled: EN13501-1 B s2 d0 Steel mineral wool filled: EN 13501-2:2008 A2 s1 d0 fire class rating and EI60 fire resistance
Panel Weights	between 8.00 / m ² – 17.9 / m ²
Panel Heights	between 1.12m – 5.00m
Panel Width	between 0.5m - 1m
Panel Depth	between 30mm – 80mm
Support Operations	Floor-to-ceiling; supplied with u-channel fixings, Free-standing; bolt down, equal, offset weighted and universal

For factory and warehouse environments, Hoardfast is available in our Standard uPVC hollow fluted panel and steel faced PIR foam or mineral filled panel. Different system specifications are capable of achieving up to 1-hour fire retardancy and sound reduction up to 34dB.

