



Recycled Plastic

MUSKETEER™

Our **Musketeer**™ recycled plastic lectern displays are made from 100% recycled UK plastic waste. They offer an eco-friendly interpretation display solution that requires minimal maintenance and will never rot or degrade.

Interpretation panels are presented at a low angle, ideal for children and wheelchair users or in areas where space is limited. Twin leg and single leg lecterns are available in a range of sizes to accommodate larger and smaller interpretation boards.

Product features

- Wood effect recycled plastic construction
- 100% recyclable
- No maintenance required
- Tamper resistant fixings
- Removable graphic panel
- Easy access for children and wheelchair users
- Cedar effect finish
- Standard sizes A3, A2, A1 and A0
- Standard panoramic sizes 900mm x 300mm, 1200mm x 400mm and 1500mm x 500mm
- 1 year manufacturer's warranty

Specification applies to the standard product.
Our range of options usually allow us to accommodate any differences you may require.
Please contact us and we will be happy to support you in developing this specification to meet your requirements.

Manufacturer: Fitzpatrick Woolmer,
Unit 7 Lakeside Park, Neptune Close,
Rochester, Kent, ME2 4LT.
Tel: 01634 711 771
Email: info@fwdp.co.uk

Material: Polystyrene foam

Origin: UK

Certification: 100% recycled plastic waste

Finish: Cedar effect

Visible fixings: Stainless steel security fixings to removable parts

Capacity: Will accommodate a 3mm thick printed graphic panel

Weight: 43kg

Installation: Posts extend 500mm below ground level

Guarantee: One year manufacturer's warranty

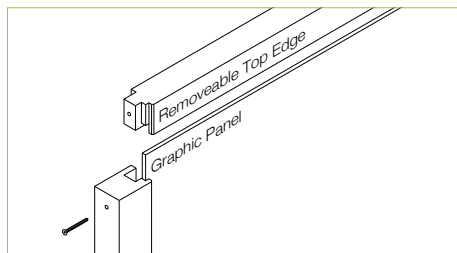

Standard frame assembly

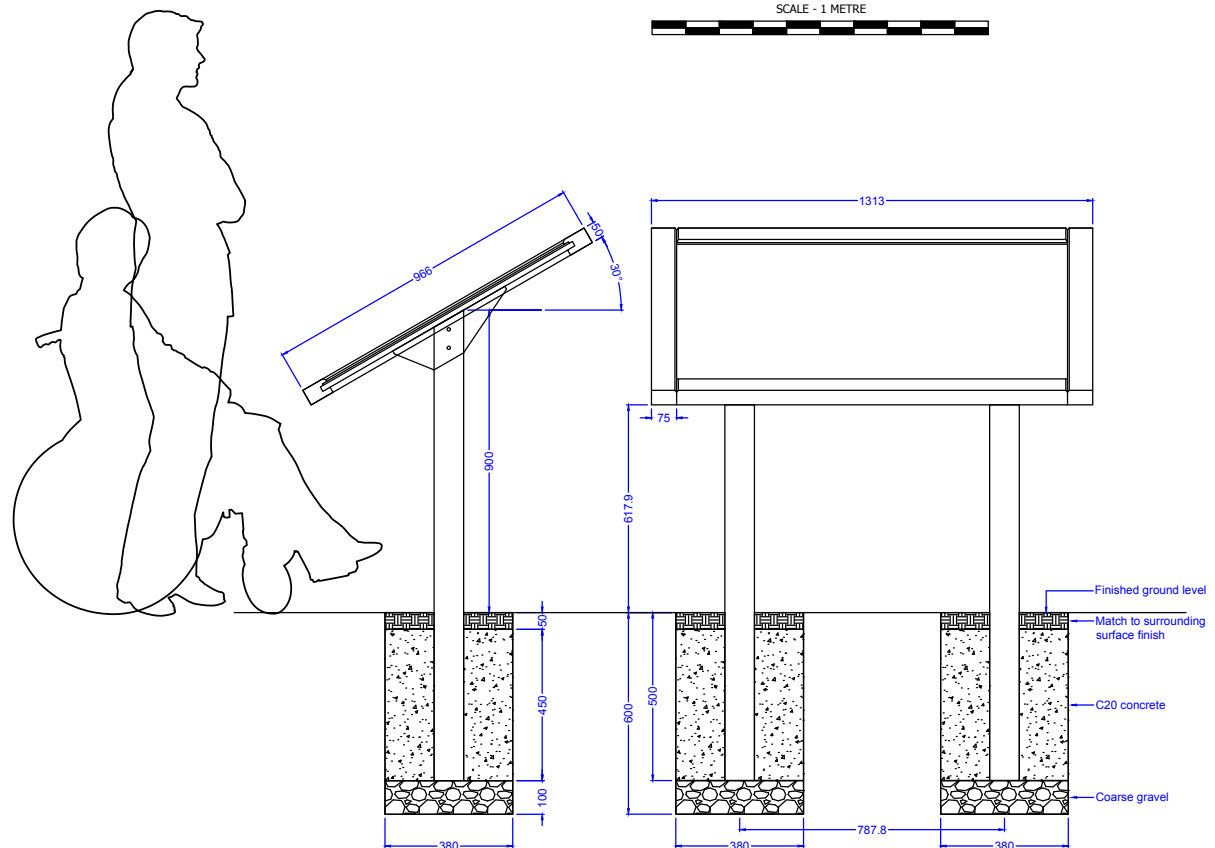

Note:
All dimensions are indicative only.
Footing details are subject to
soil conditions and structural
engineers recommendations.

Specification applies to the standard product. Our range of options usually allow us to accommodate any differences you may require. Please contact us and we will be happy to support you in developing this specification to meet your requirements.

Manufacturer: Fitzpatrick Woolmer,
Unit 7 Lakeside Park, Neptune Close,
Rochester, Kent, ME2 4LT.
Tel: 01634 711 771
Email: info@fwdp.co.uk

Material: Polystyrene foam

Origin: UK

Certification: 100% recycled plastic waste

Finish: Cedar effect

Visible fixings: Stainless steel security fixings to removable parts

Capacity: Will accommodate a 3mm thick printed graphic panel

Weight: 32kg

Installation: Posts extend 500mm below ground level

Guarantee: One year manufacturer's warranty

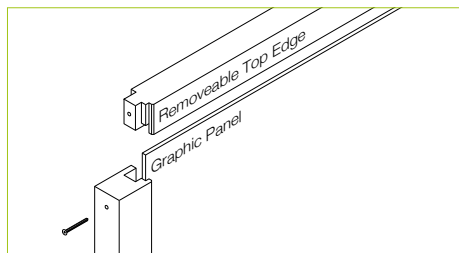

Standard frame assembly

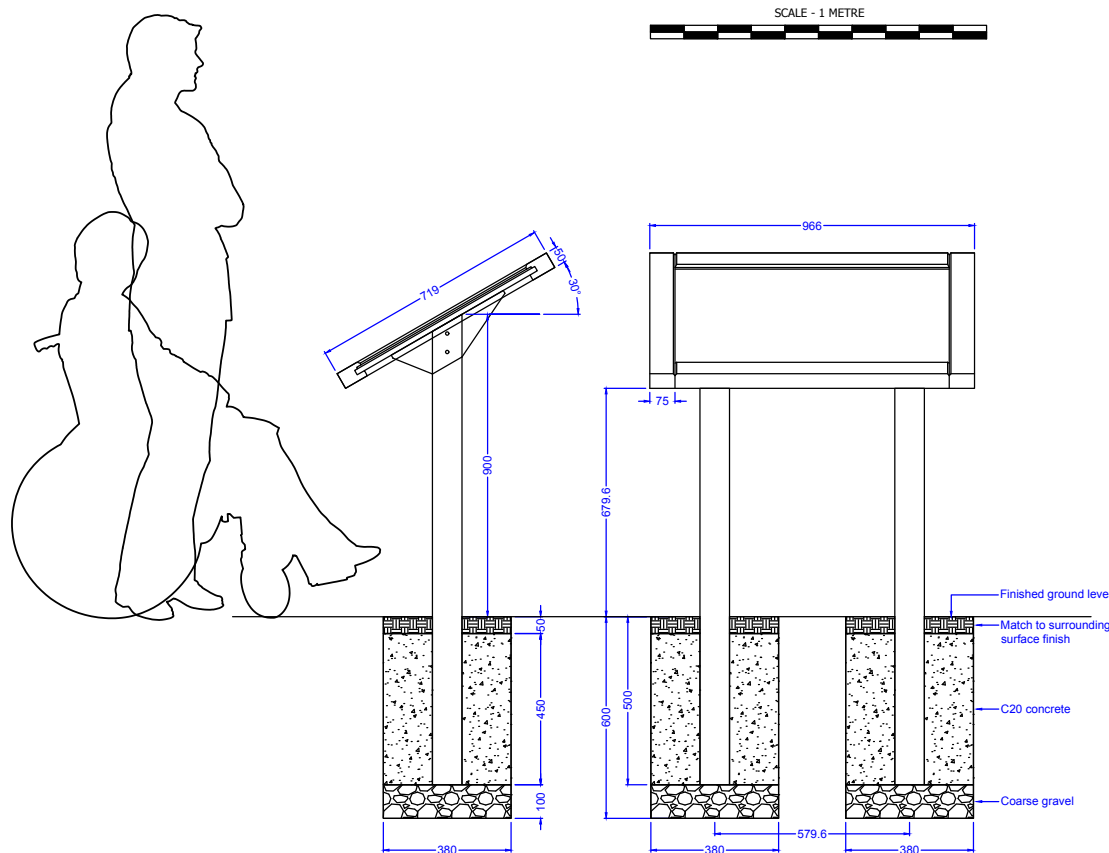

Note:
All dimensions are indicative only.
Footing details are subject to
soil conditions and structural
engineers recommendations.

Specification applies to the standard product. Our range of options usually allow us to accommodate any differences you may require. Please contact us and we will be happy to support you in developing this specification to meet your requirements.

Manufacturer: Fitzpatrick Woolmer,
Unit 7 Lakeside Park, Neptune Close,
Rochester, Kent, ME2 4LT.
Tel: 01634 711 771
Email: info@fwdp.co.uk

Material: Polystyrene foam

Origin: UK

Certification: 100% recycled plastic waste

Finish: Cedar effect

Visible fixings: Stainless steel security fixings to removable parts

Capacity: Will accommodate a 3mm thick printed graphic panel

Weight: 26kg

Installation: Posts extend 500mm below ground level

Guarantee: One year manufacturer's warranty

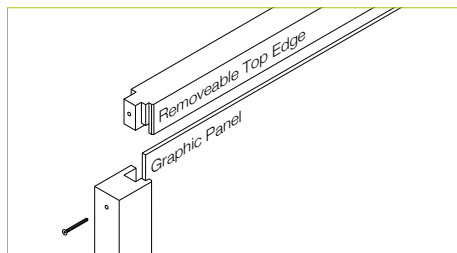

Standard frame assembly

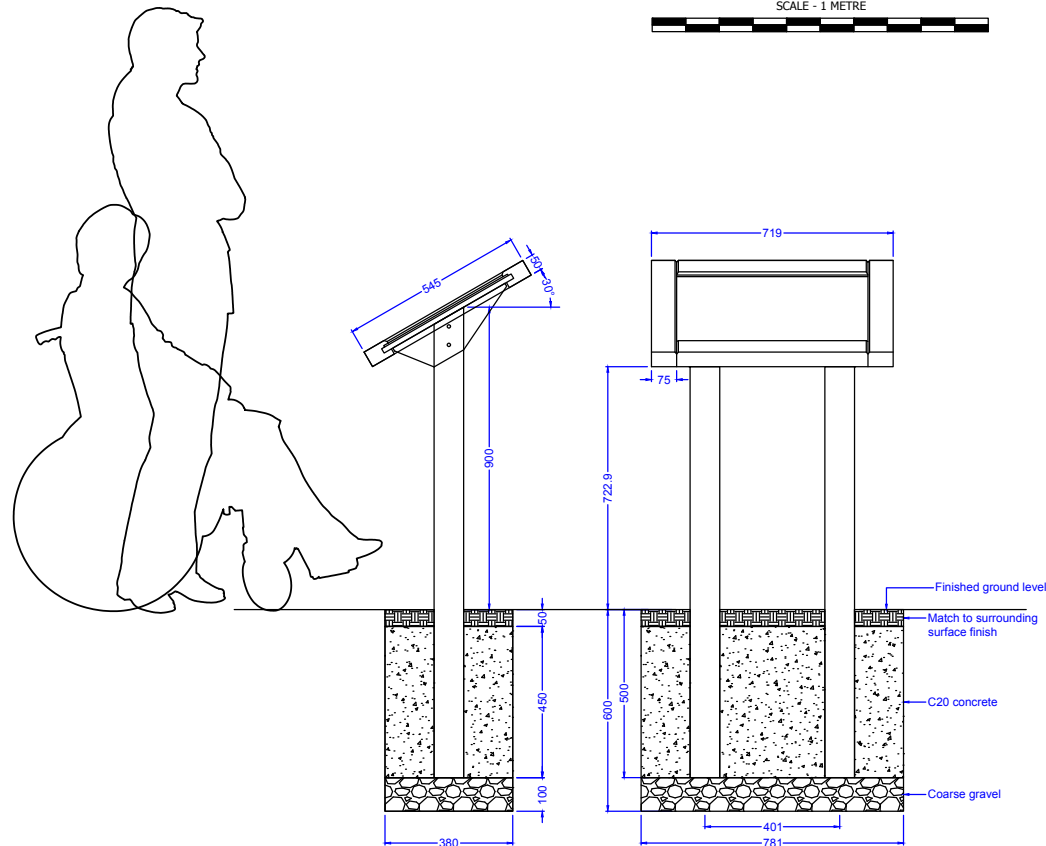

Note:
All dimensions are indicative only.
Footing details are subject to
soil conditions and structural
engineers recommendations.

Specification applies to the standard product. Our range of options usually allow us to accommodate any differences you may require. Please contact us and we will be happy to support you in developing this specification to meet your requirements.

Manufacturer: Fitzpatrick Woolmer,
Unit 7 Lakeside Park, Neptune Close,
Rochester, Kent, ME2 4LT.
Tel: 01634 711 771
Email: info@fwdp.co.uk

Material: Polystyrene foam

Origin: UK

Certification: 100% recycled plastic waste

Finish: Cedar effect

Visible fixings: Stainless steel security fixings to removable parts

Capacity: Will accommodate a 3mm thick printed graphic panel

Weight: 19kg

Installation: Posts extend 500mm below ground level

Guarantee: One year manufacturer's warranty

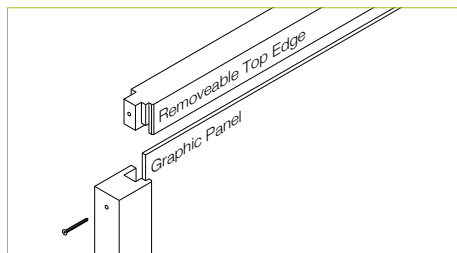

Standard frame assembly

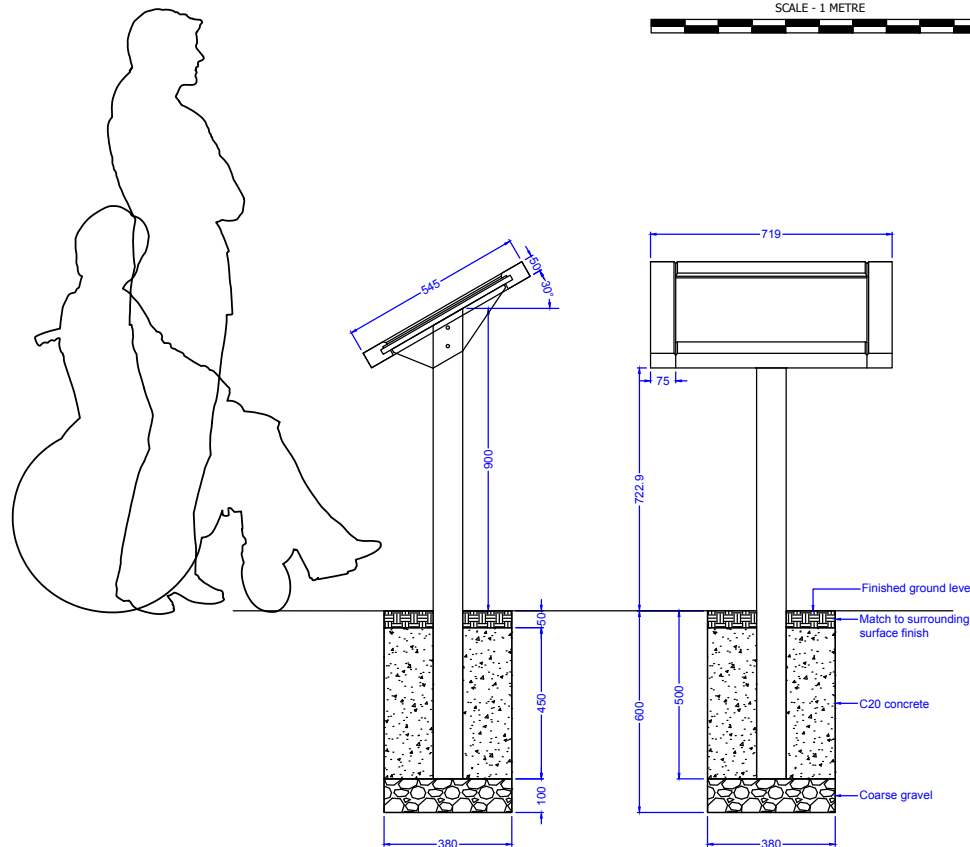

Note:
All dimensions are indicative only.
Footing details are subject to
soil conditions and structural
engineers recommendations.

Specification applies to the standard product. Our range of options usually allow us to accommodate any differences you may require. Please contact us and we will be happy to support you in developing this specification to meet your requirements.

Manufacturer: Fitzpatrick Woolmer,
Unit 7 Lakeside Park, Neptune Close,
Rochester, Kent, ME2 4LT.
Tel: 01634 711 771
Email: info@fwdp.co.uk

Material: Polystyrene foam

Origin: UK

Certification: 100% recycled plastic waste

Finish: Cedar effect

Visible fixings: Stainless steel security fixings to removable parts

Capacity: Will accommodate a 3mm thick printed graphic panel

Weight: 16kg

Installation: Posts extend 500mm below ground level

Guarantee: One year manufacturer's warranty

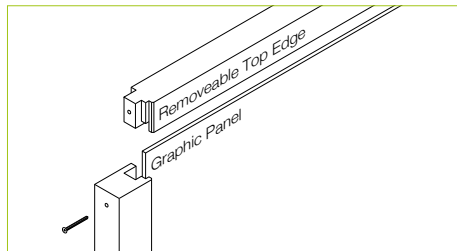

Standard frame assembly

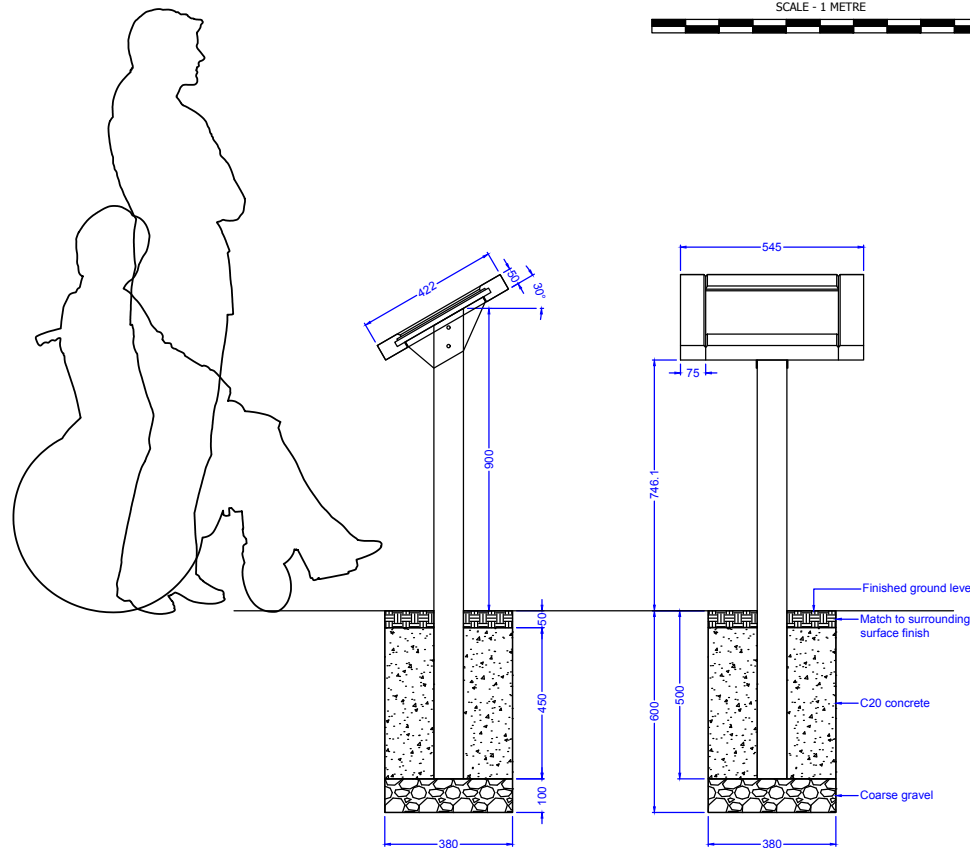

Note:
All dimensions are indicative only.
Footing details are subject to
soil conditions and structural
engineers recommendations.

Specification applies to the standard product. Our range of options usually allow us to accommodate any differences you may require. Please contact us and we will be happy to support you in developing this specification to meet your requirements.

Manufacturer: Fitzpatrick Woolmer,
Unit 7 Lakeside Park, Neptune Close,
Rochester, Kent, ME2 4LT.
Tel: 01634 711 771
Email: info@fwdp.co.uk

Material: Polystyrene foam

Origin: UK

Certification: 100% recycled plastic waste

Finish: Cedar effect

Visible fixings: Stainless steel security fixings to removable parts

Capacity: Will accommodate a 3mm thick printed graphic panel

Weight: 25kg

Installation: Posts extend 500mm below ground level

Guarantee: One year manufacturer's warranty

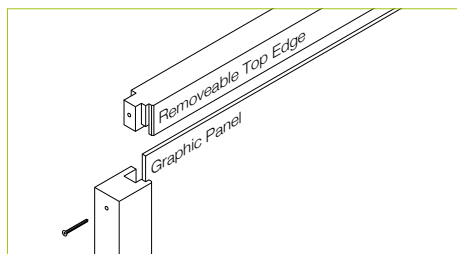

Standard frame assembly

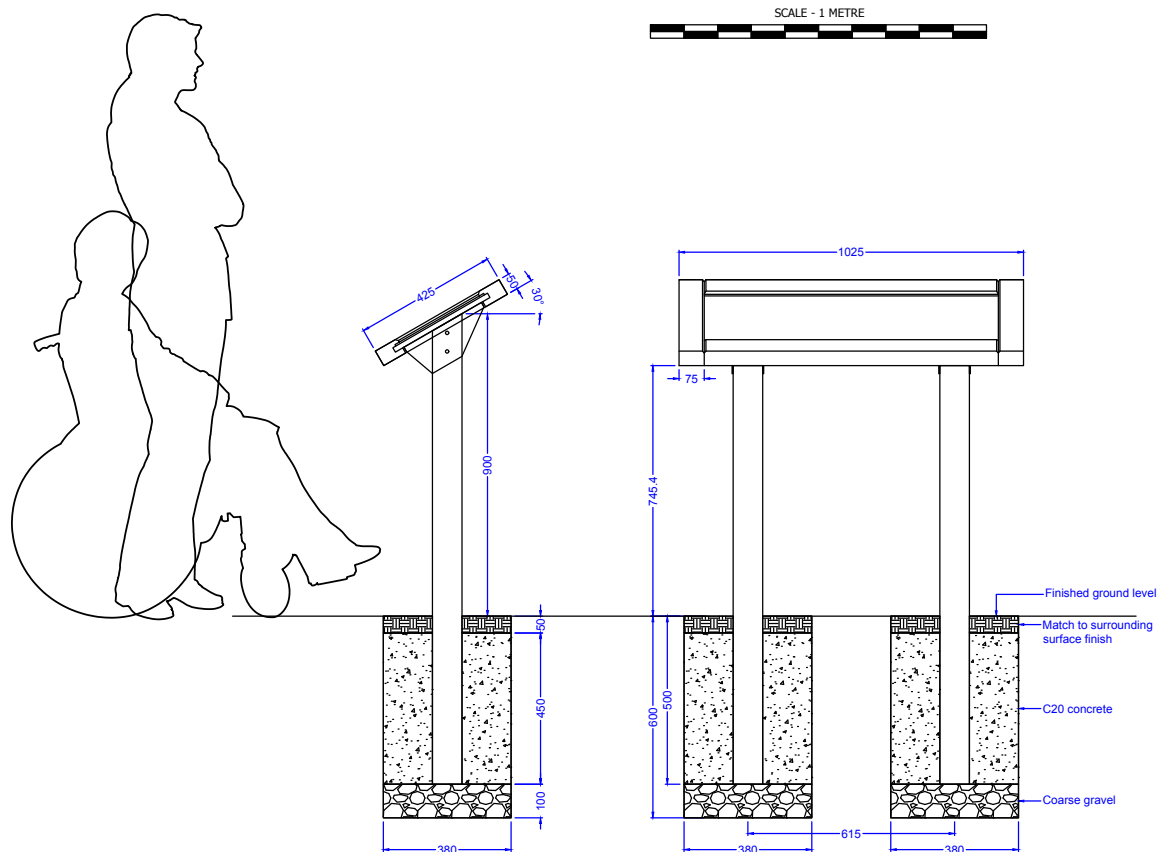

Note:
All dimensions are indicative only.
Footing details are subject to
soil conditions and structural
engineers recommendations.

Specification applies to the standard product. Our range of options usually allow us to accommodate any differences you may require. Please contact us and we will be happy to support you in developing this specification to meet your requirements.

Manufacturer: Fitzpatrick Woolmer,
Unit 7 Lakeside Park, Neptune Close,
Rochester, Kent, ME2 4LT.
Tel: 01634 711 771
Email: info@fwdp.co.uk

Material: Polystyrene foam

Origin: UK

Certification: 100% recycled plastic waste

Finish: Cedar effect

Visible fixings: Stainless steel security fixings to removable parts

Capacity: Will accommodate a 3mm thick printed graphic panel

Weight: 32kg

Installation: Posts extend 500mm below ground level

Guarantee: One year manufacturer's warranty

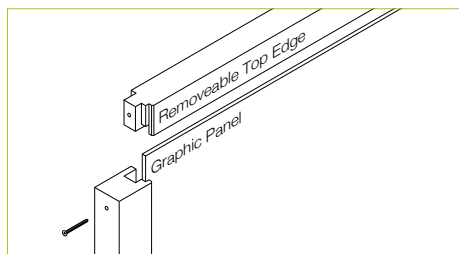

Standard frame assembly

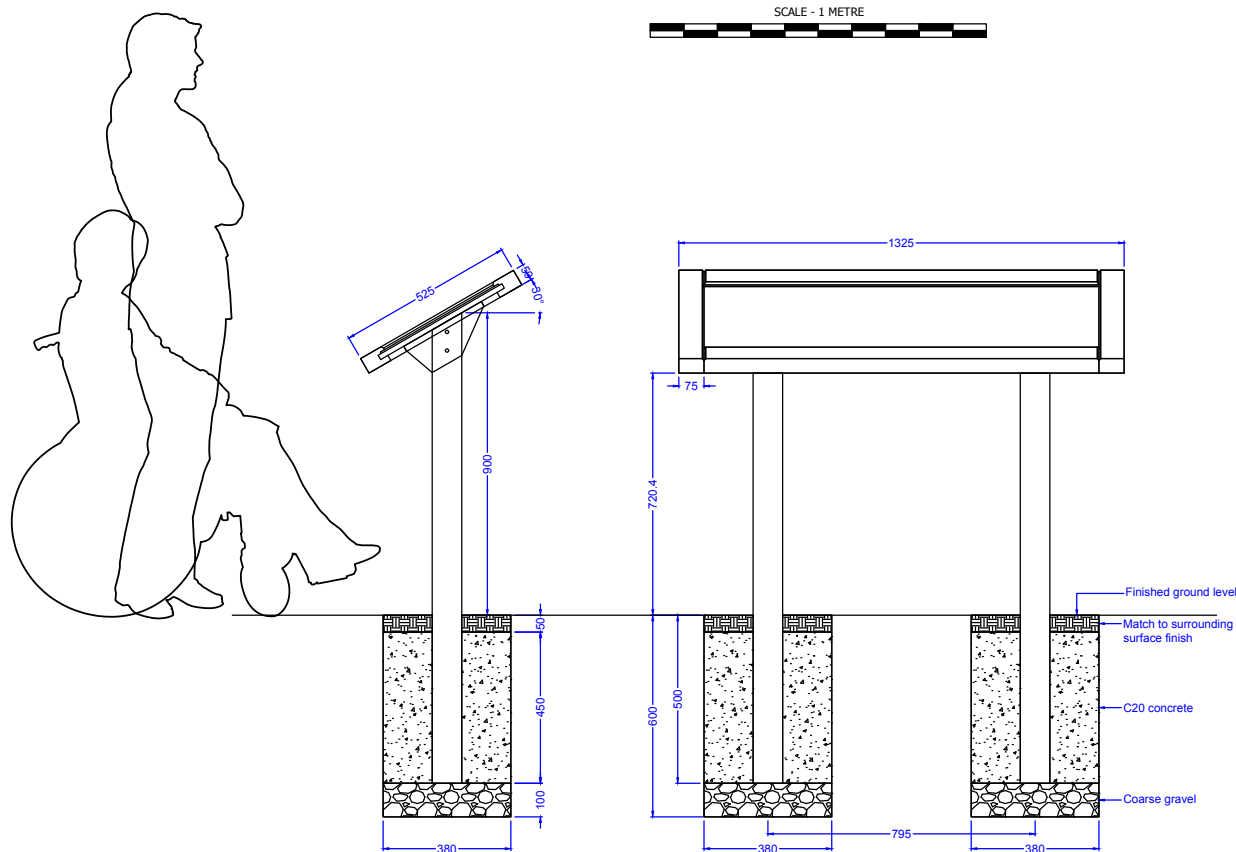

Note:
All dimensions are indicative only.
Footing details are subject to
soil conditions and structural
engineers recommendations.

Specification applies to the standard product. Our range of options usually allow us to accommodate any differences you may require. Please contact us and we will be happy to support you in developing this specification to meet your requirements.

Manufacturer: Fitzpatrick Woolmer,
Unit 7 Lakeside Park, Neptune Close,
Rochester, Kent, ME2 4LT.
Tel: 01634 711 771
Email: info@fwdp.co.uk

Material: Polystyrene foam

Origin: UK

Certification: 100% recycled plastic waste

Finish: Cedar effect

Visible fixings: Stainless steel security fixings to removable parts

Capacity: Will accommodate a 3mm thick printed graphic panel

Weight: 38kg

Installation: Posts extend 500mm below ground level

Guarantee: One year manufacturer's warranty

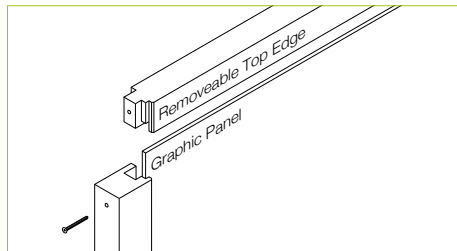

Standard frame assembly

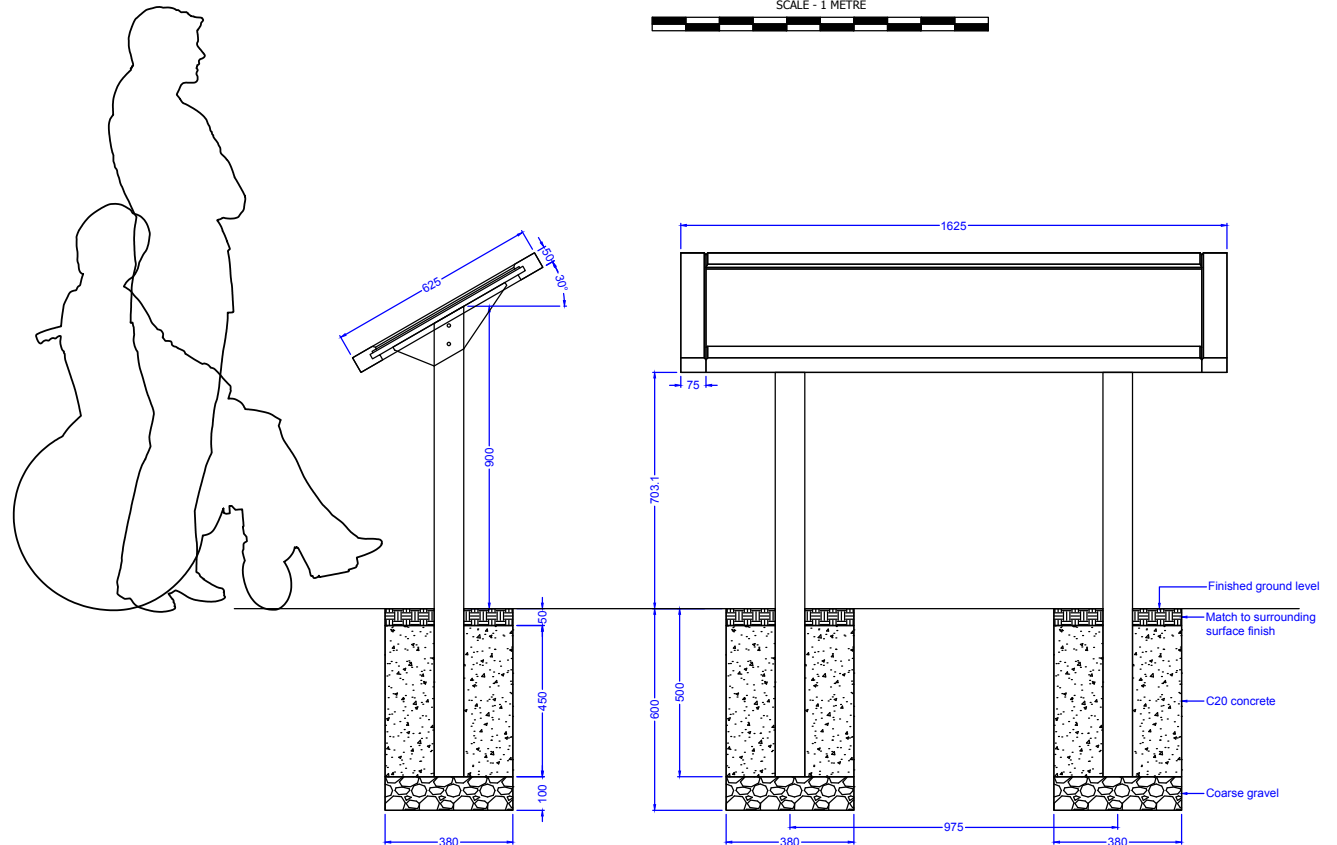

Note:
All dimensions are indicative only.
Footing details are subject to
soil conditions and structural
engineers recommendations.