



The mark of responsible forestry

'Look for FSC® certified products'



Street Design

Unit 35 Hayhill Industrial Estate Barrow upon Soar Leicestershire LE12 8LD
01509 815335 sdl@street-design.com www.street-design.com

UK Street Furniture Designers & Manufacturers

DIPLOMAT planter

The Diplomat planter is a versatile, all timber planter suitable for a wide range of applications. It is available with a choice of material and finishes.

Choose from a range of accessories to ensure that the Diplomat planter is manufactured to suit your specific requirements.

Diplomat planters are suitable for:

- Roof Garden planters
- Modular planters
- Tree planters
- Large planters
- Barrier planters
- Shaped planters
- Moveable planters
- Planter Walling (without base)
- Planters with integral bench seating

Diplomat planter product details

Diplomat planter product specification

Diplomat planter accessories

Watering system accessories

Adjustable feet accessory

Diplomat planter material finishes

Diplomat planter material specification

Diplomat planter care and maintenance



Diplomat tree planters and planter walling in FSC®-certified treaded redwood with a natural finish

DIPLOMAT planter

PRODUCT DETAILS

General

The Diplomat external planter, is a versatile, multi-use and cost effective planter, available in a choice of materials and finishes to suit your scheme and budget.

The planter is available in either FSC®-certified hardwood or a FSC®-certified treated European, joinery quality redwood. Planters up to 2.8x2.8m plan size will be delivered fully assembled ready for planting.

Larger planters will be manufactured in sections and delivered for assembly on site.

Other shapes can be manufactured and supplied including:- triangular, hexagonal, octagonal and any other irregular straight sided shape.

Planters can be manufactured with additional steel support to enable the planters to be moved when fully planted.



Section thro' planter

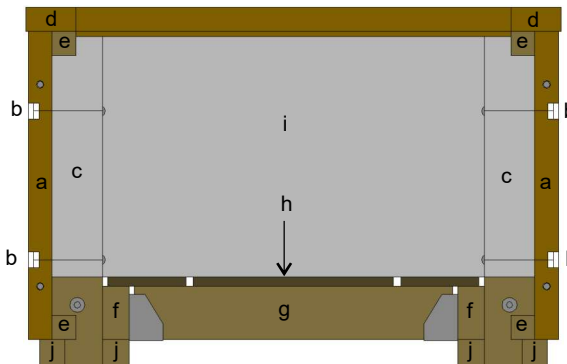

Key

- a - 95 x 45mm FSC®-certified vertical timber slats
- b - M12 cup square coachbolts
- c - 95 x 95mm FSC®-certified timber posts
- d - 95 x 45mm FSC®-certified timber capping
- e - 45 x 45mm FSC®-certified wall panel bearers
- f - 100 x 47mm FSC®-certified timber bearers
- g - 100 x 47mm FSC®-certified timber bearers
- h - 18mm FSC®-certified hardwood faced plywood
- i - Geo-textile membrane filter lining
- j - 45mm high FSC®-certified timber blocks

Construction

The Diplomat, all timber planter, is constructed by bolting 95x45mm section vertical walling slatted panels to 95x95mm section posts. A 45x45mm corner fillet is fitted into the external corner to ensure a neat detail.

A 95x45mm section timber top capping is screw fixed to the wall panel. The screw holes will be countersunk and plugged.

The internal base is constructed using 100x47mm sawn treated softwood bearers, fixed to the posts and fitted to joist hangers fixed to the main bearers. Plywood sheeting is fixed down onto the bearers. 45mm high timber blocks are fitted to the underside of the bearers, to ensure that the load is safely transferred to the ground. When fully constructed, the inside of the planter is fully lined with a geo-textile lining, that allows water to drain through whilst retaining the soil fines.

Typical plan sizes, heights and basic shapes of Diplomat planters

| Plan dimensions and material options | all other sizes, heights and plan shapes can be manufactured and supplied | | | | |
|--------------------------------------|---|-------|-------|--------|--------|
| Square | Planter heights | | | | |
| 0.5 x 0.5m | 400mm | 600mm | 800mm | 1000mm | 1200mm |
| FSC®-certified treated redwood | • | • | • | • | • |
| FSC®-certified hardwood | • | • | • | • | • |
| 1.0 x 1.0m | | | | | |
| FSC®-certified treated redwood | • | • | • | • | • |
| FSC®-certified hardwood | • | • | • | • | • |
| 1.2 x 1.2m | | | | | |
| FSC®-certified treated redwood | • | • | • | • | • |
| FSC®-certified hardwood | • | • | • | • | • |
| 1.5 x 1.5m | | | | | |
| FSC®-certified treated redwood | • | • | • | • | • |
| FSC®-certified hardwood | • | • | • | • | • |
| 2.0 x 2.0m | | | | | |
| FSC®-certified treated redwood | • | • | • | • | • |
| FSC®-certified hardwood | • | • | • | • | • |
| 2.8 x 2.8m | | | | | |
| FSC®-certified treated redwood | • | • | • | • | • |
| FSC®-certified hardwood | • | • | • | • | • |
| Rectangular | | | | | |
| 1.0 x 0.5m | 400mm | 600mm | 800mm | 1000mm | 1200mm |
| FSC®-certified treated redwood | • | • | • | • | • |
| FSC®-certified hardwood | • | • | • | • | • |
| 2.0 x 1.0m | | | | | |
| FSC®-certified treated redwood | • | • | • | • | • |
| FSC®-certified hardwood | • | • | • | • | • |
| 2.8 x 1.0m | | | | | |
| FSC®-certified treated redwood | • | • | • | • | • |
| FSC®-certified hardwood | • | • | • | • | • |

DIPLOMAT planter

PRODUCT SPECIFICATION



Unit 35 Hayhill Industrial Estate Barrow upon Soar Leicestershire LE12 8LD
 01509 815335 sdl@street-design.com www.street-design.com
 UK Street Furniture Designers & Manufacturers

| Technical information | | | | | | |
|--|--|-----|-----|------|------|------|
| Material | | | | | | |
| Vertical walling slats | 95 x 45mm FSC®-certified treated redwood or FSC®-certified hardwood | | | | | |
| External corner detail | 45 x 45mm FSC®-certified treated redwood or FSC®-certified hardwood | | | | | |
| Top capping | 95 x 45mm FSC®-certified treated redwood or FSC®-certified hardwood | | | | | |
| Internal corner posts | 95 x 95mm FSC®-certified treated redwood | | | | | |
| Base bearers | 100 x 47mm FSC®-certified treated redwood | | | | | |
| Base flooring | 18mm FSC®-certified hardwood faced plywood | | | | | |
| Fixings | M12 size - bright zinc plated | | | | | |
| Standard finish | Natural treated redwood or hardwood | | | | | |
| Optional finish | Stained finish on request | | | | | |
| Accessories | Integral bench seating Tree anchors Watering System Trellis panels Pergola structure Internal steel frame Height adjustable feet | | | | | |
| Guarantee | All planters are guaranteed for 15 years | | | | | |
| Walling heights (mm) | 400 | 600 | 800 | 1000 | 1200 | 1400 |
| Planting depths (mm) | 232 | 432 | 632 | 832 | 1032 | 1232 |
| Weights | | | | | | |
| Treated redwood planter walls (kgs / lm) | 16 | 22 | 28 | 34 | 40 | 46 |
| Hardwood planter walls (kgs / lm) | 22 | 33 | 44 | 55 | 66 | 77 |
| Planter base (kgs / m ²) | 19 | 19 | 19 | 19 | 19 | 19 |
| Light fill material can be based on: | 1000 kgs / m ³ | | | | | |
| Heavy fill material can be based on: | 2000 kgs / m ³ | | | | | |

Timber policy

All treated softwood planters are manufactured using materials obtained from growers who operate under the Forest Stewardship Council (FSC®).

All hardwood planters are manufactured using materials obtained from growers who operate under the Forest Stewardship Council (FSC®).

Construction

All Street Design products are designed and manufactured using only quality, durable materials, construction details and fixings, to provide a long-lasting, durable life expectancy.

Assembly

Planters up to 2.8 x 2.8m will be delivered to site fully assembled for off loading and positioning on site. Planters larger than 2.8m will be supplied in sections for bolting together on site.

Materials

Hardwood planters are constructed from FSC®-certified hardwood, from sustainable sources. Softwood planters are constructed using FSC®-certified European redwood that has been pressure treated, for a desired service life of 15 years minimum.

All mild steel fixings will be M10 or M12 size and have a bright zinc plated finish. Planters will be fitted with a geo-textile filter fabric lining, which allows the water to drain through the planter, while retaining the fill material.

Standard finish

FSC®-certified treated softwood and hardwood will be left natural to reduce the need for re-staining and help reduce maintenance costs.

Optional finish

Stained finish is available on request.

Options

Diplomat planters are manufactured to order. Before we can manufacture the planters, we need to know the following:

- plan size and shapes
- heights
- material
- finish
- details of any accessories required

Accessories

To enhance your Diplomat planter and create a product that is suitable for your specific application, you can add from a range of planter accessories.

- Tree anchors
- Adjustable feet
- Watering system
- Integral bench seating
- Internal steel frame
- Pergola structures
- Trellis panels



FSC Certified hardwood large planter with a natural finish



FSC®-certified treated redwood Tall planter with a natural finish



Large FSC®-certified treated redwood planters with a natural finish

DIPLOMAT planter

ACCESSORIES

Diplomat planters can be manufactured and supplied to include a range of optional accessories.

Planters can incorporate; adjustable feet, tree anchor fittings, watering systems, bench seating, pergolas and trellis panels.

Adjustable feet

Diplomat planters can be manufactured with optional adjustable feet to allow the planter to be height adjusted to ensure that the top of the planter is level. The adjustable feet, allow the planter to be levelled after relocation. See separate page for Adjustable Feet details.

Watering system

Diplomat planters can be supplied with a choice of 2 watering systems. Street Design can supply either a reservoir system, with filler pipe or the Mona, subterranean tank system. See separate page for Watering System details.

Moveable planters

Diplomat planters can be supplied with an internal steel frame to allow the planters to be moved whilst fully planted. The steel frame provides additional strength and ensures suitable supports for the forklift tines.

Planter Walling (supplied without a base)

Diplomat planters can be supplied as walling only, without a base. Walling panels are manufactured in sections and delivered to be bolted together on site.

Tree anchor fittings

Diplomat planters can be fitted with galvanised mild steel tree anchor points. They can be fitted at the bottom of the planter to help support the root ball and they can be fitted at the top of the planter to help provide support for the tree.

The tree anchors are manufactured using 25x5mm mild steel flat. They have two punched slots and are fitted to the projecting bolt ends on the inside of the planter. The tree anchors are hot dip galvanised.

Pergola structures and trellis panels

By extending the planter posts, pergola structures and trellis panels can be integrated into the planter construction. Pergolas and trellis allow high level planting and create shaded areas for seating.

Bench seating

Integral planter benches, with or without armrests, can be supplied with Diplomat planters. As standard 2 bench designs are available. Other designs can be included upon request. The Bexley bench consists of 4 no. 70x45mm timber slats and the Henley bench has 2 no. 145x45mm wide bench slats. The timber slatted benches bolt onto galvanised mild steel brackets, attached to the planter sides. Benches can be fitted to 1, 2, 3 or 4 sides to suit your requirements. The choice of material and finish is the same as for the planter. As standard the brackets will have a galvanised finish. As an optional extra, they can be polyester powder coated.

Planter bench configurations



bench on 1 side



bench on 2 sides opposite



bench on 2 sides adjacent



bench on 2 sides adjacent (mitred)



bench on 3 sides



bench on 3 sides (mitred)



bench on 4 sides



bench on 4 sides (mitred)



Diplomat planter with optional curved Spalding planter bench

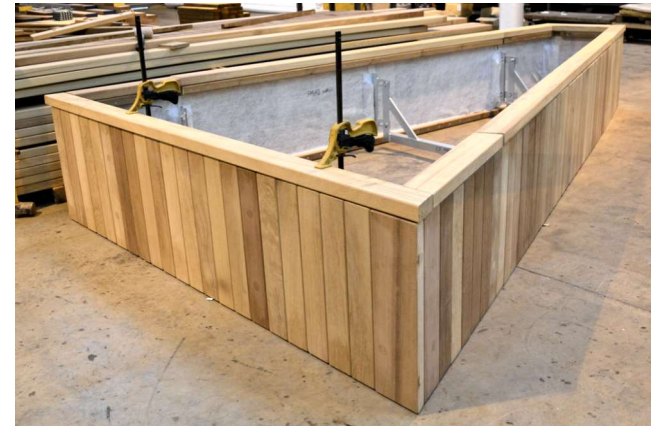

Diplomat planter walling (supplied without a base)

DIPLOMAT planter

WATERING SYSTEMS

Watering System 1 - Street Design reservoir system

The Street Design watering accessory is a reservoir system with hydroleca sacks, that maximises the available water.

The system ensures the optimum use of the water and nutrients, delivering the maximum quantity directly to the roots of the plants, resulting in improved root development and optimal plant growth.

General

The system consists of a 300 micron thick black polythene liner, hydroleca (pulverised ash granules) sacks and a rigid plastic filler pipe.

The system delivers water directly to the roots via 50mm diameter, rigid plastic pipe, eliminating water wastage. This encourages deep root growth, improving long term drought resistance. The high level filler pipe provides an easy access point for watering and soluble fertiliser application.

Installation

Planters are supplied with the Water System 1 already installed.

Ensure the hydroleca sacks are in the correct position. They will move during transportation. Check that all the plastic pipe connections are properly fitted. The planter is ready for drainage material, filling and planting.

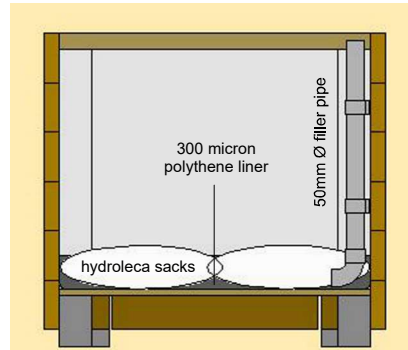

Watering System 1 - Section thro' planter



Polythene liner with filler pipe



Hydroleca sacks laid out in base of planter

Watering System 2 - MONA subterranean tank system

Mona watering system

Factory fitted into planter / tree container

The Mona Plant System (MPS) is an advanced, well proven and easy to use subterranean irrigation system. It is the cost effective and environmentally friendly solution for both interior and exterior landscaping.

The Mona Plant System ensures that the water and nutrients are delivered in the right quantity to the root of the plants, resulting in improved root development and optimal plant growth.

General

The system consists of storage tanks, flexible linking pipes and a flexible filler pipe with filler pipe cap. The system delivers water directly to the roots via capillary action, eliminating water wastage. This encourages deep root growth, improving long term drought resistance. The cap and lid provides an easy access point for watering and soluble fertiliser application.

Factory installation

All necessary water tanks, pipes, end caps and air pipes with level indicator, are factory fitted into the planters / tree containers, prior to delivery.

Filling planters

Ensure that the distance between the top of the link tank and the lowest part of the root does not exceed 150mm.

For full details visit: www.green-tech.co.uk



Water storage tanks and filler pipe



Planter ready for soil and planting



Completed planter

DIPLOMAT planter

ADJUSTABLE FEET

General details

As an extra cost option, Street Design planters can be supplied with adjustable feet. They allow the planter to be levelled, before filling and planting.

Adjustable feet are particularly useful if the planters are likely to be relocated to a new position.

The adjustable foot screw fits into a hex nut, located on the underside of the planter base.

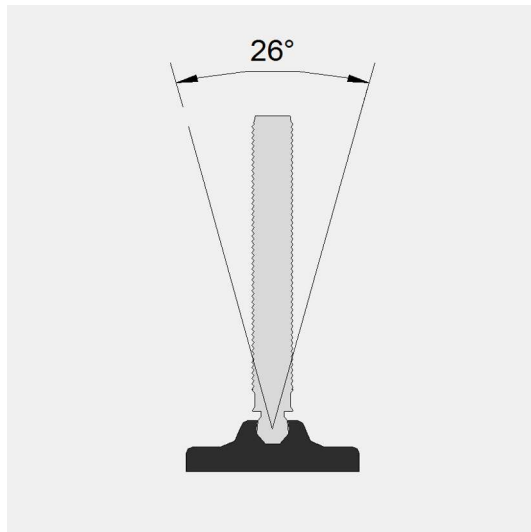

Specification

The adjustable foot comprises of a M30 Ø threaded bar, with spherical end section, press fitted into a black reinforced polyamide base.

The swivel base can tilt through 360° to accommodate sloping ground levels.

The threaded bar is BZP (bright zinc plated) treated.

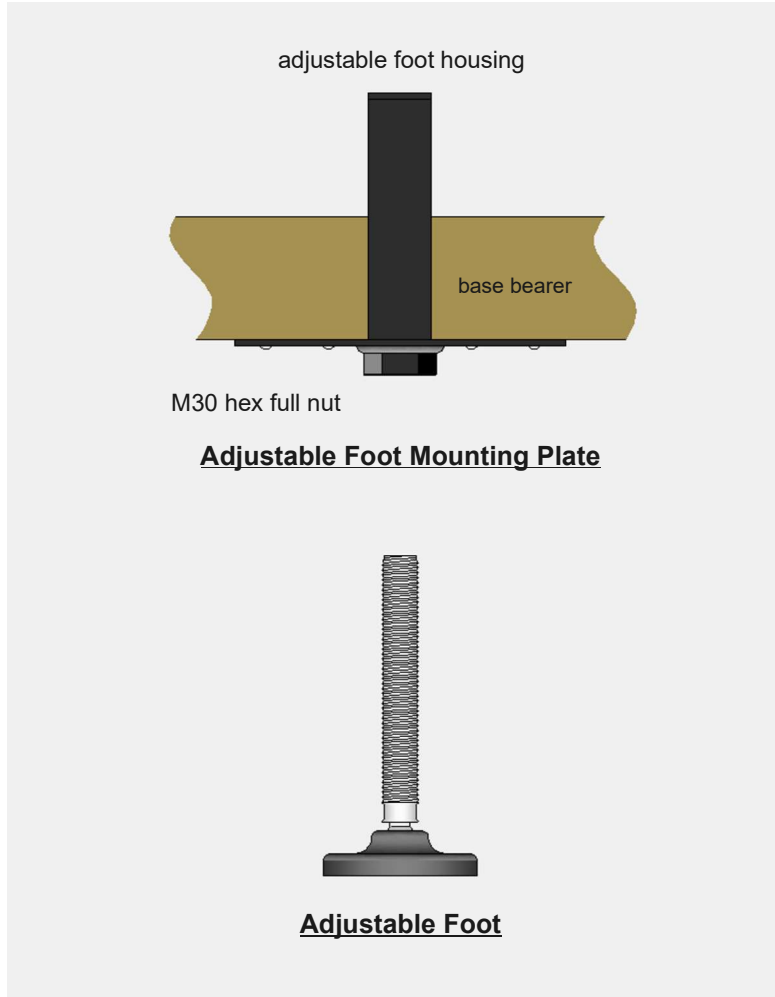

Fitting and adjustment

The M30 adjustable foot with swivel base, is screwed into adjustable foot mounting plate.

The mild steel mounting plate with adjustable foot housing, is fixed to the underside of the planter base.

A M30 hex full nut is welded to the underside of the mounting plate.

The adjustable foot is adjusted with a 26mm wrench.



Base diameter

M30 adjustable foot with swivel base. The base diameter is 122mm.



Swivel base

The swivel base can adjust to allow for sloping ground with a fall of up to 1 in 2.06 (26°).



Bolt down base

For extra security, it is possible to drill and bolt through the base of the adjustable feet.

DIPLOMAT planter

MATERIAL SPECIFICATION

Standard planter

Posts

FSC®-certified 95x95mm FIN PAR pressure treated European redwood.

Base bearers

FSC®-certified 100x47mm section sawn, pressure treated European redwood.

Wall panels

FSC®-certified 95x45mm FIN PAR pressure treated European redwood or FSC®-certified hardwood, with 45x45mm top and bottom bearers.

Corner fillets

FSC®-certified 45x45mm FIN PAR pressure treated European redwood or FSC®-certified hardwood.

Top cappings

FSC®-certified 95x45mm FIN PAR pressure treated European redwood or FSC®-certified hardwood.

Base floor

18mm FSC®-certified hardwood faced plywood.

Internal lining

Geo-textile membrane.

Fixing bolts

M12x160mm coach bolts with a BZP finish.

Joist hangers

LUS/230/50 U sheer light nailing hangers with a BZP finish.

Optional planter accessories

Adjustable feet

M30 adjustable feet with swivel base. See Adjustable Foot page for full details.

Tree anchors

25x5mm mild steel flat tree anchor brackets, hot dip galvanised.

Watering system

Choose either the Street Design reservoir system or the Mona tank system. See Watering System page for full details.

Optional planter accessories continued

Planter benches

Timber bench slats to match planter material in either FSC®-certified treated European redwood or FSC®-certified hardwood, bolted to hot dip galvanised mild steel bench brackets.

Moveable planters

Diplomat planters can be manufactured with an internal mild steel frame and are suitable for moving.

Pergola structures

Pergola structures can be manufactured as an integral part of the planter construction. The steel uprights can be extended to carry the upper horizontal 145x45mm section timber bearers and cross bearers.

Trellis panels

Trellis panels can be manufactured as an integral part of the planter construction. The steel uprights can be extended to carry the horizontal and vertical trellis timber slats.

Guarantee

All planters are guaranteed for 15 years. This guarantee is dependant on the product not being misused or abused.

Product prices

Contact our Sales Office on 01509 815335 for Diplomat planter prices delivered to site.



Unit 35 Hayhill Industrial Estate Barrow upon Soar Leicestershire LE12 8LD
01509 815335 sdl@street-design.com www.street-design.com

 UK Street Furniture Designers & Manufacturers

General specification

Construction

All Street Design products are designed and manufactured using only quality, durable materials, construction details and fixings, to provide a long-lasting, durable life expectancy.

Assembly

Diplomat planters up to 2.8 x 2.8m will be delivered to site fully assembled for off loading and positioning on site. Planters larger than 2.8m will be supplied in sections for bolting together on site.

Timber policy

All treated redwood products are manufactured using materials obtained from growers who operate under the Forest Stewardship Council (FSC). All hardwood products are manufactured using materials obtained from growers who operate under the Forest Stewardship Council (FSC).

Materials

Hardwood products are constructed using FSC®-certified hardwood, from sustainable sources. Softwood products are constructed using FSC®-certified European redwood that has been pressure treated, for a desired service life of 15 years in-ground contact.

All mild steel fabricated components will be hot dip galvanised after fabrication to BS EN ISO 1461:2009.

All stainless steel fabricated components will be grade 304. Grade 316 can be specified if the location or project requires it.

All mild steel fixings will be bright zinc plated, and all stainless steel fixings will be A2 (grade 304). A4 (grade 316) can be specified if the location or project requires it.

Planters will be fitted with a geo-textile filter fabric lining, which allows the water to drain through the planter, while retaining the fill material.

Finishes

FSC®-certified treated redwood and FSC®-certified hardwood will be left natural to reduce the need for re-staining and help reduce maintenance costs.

Optional stained finish is available on request.

Mild steel components will be left with a galvanised finish only.

Optional, additional polyester powder coated finish is available on request.

Stainless steel components will have a dull polished (brushed) finish.

Optional mirror polished or bead blasted finish is available on request.

DIPLOMAT planter

CARE & MAINTENANCE



Unit 35 Hayhill Industrial Estate Barrow upon Soar Leicestershire LE12 8LD
01509 815335 sdl@street-design.com www.street-design.com
UK Street Furniture Designers & Manufacturers

General

All Diplomat planter products are manufactured using quality materials, treatments and finishes. The timber components are manufactured from either FSC®-certified treated redwood or FSC®-certified hardwood. All products require a varied amount of maintenance, depending on the environment, usage and weather conditions. Natural timber will only require cleaning. In time, stained timber will require re-coating.

Maintaining the standard FSC®-certified treated redwood finish

Natural finish pressure treated redwood can be washed down with a mild detergent. More stubborn surface marks can be removed with a light, hand sand with a 120 grit, or higher grade sandpaper. Excessive sanding should be avoided.



Maintaining the optional FSC®-certified treated redwood finish

Stained, pressure treated redwood will need to be re-coated after a period of time. The stain can either start to fade, become dull (oxidised) or incur some surface break up. Lightly sand down the timber using a 120 grit, or higher grade sandpaper. We recommend that the timber is re-stained with the original stain colour and manufacturer. Details can be obtained from Street design Limited. Apply the stain evenly, with brush strokes running parallel with the woodgrain, in thin layers, building up the finish as recommended by the stain manufacturer.

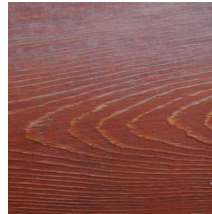

Maintaining the standard FSC®-certified hardwood finish

Natural finish hardwood can be washed down with a mild detergent. More stubborn surface marks can be removed with a light, hand sand with a 120 grit, or higher grade sandpaper. Excessive sanding should be avoided.



Maintaining the optional FSC®-certified hardwood finish

Stained, hardwood will need to be re-coated after a period of time. The stain can either start to fade, become dull (oxidised) or incur some surface break up. Lightly sand down the timber using a 120 grit, or higher grade sandpaper. We recommend that the timber is re-stained with the original stain colour and manufacturer. Details can be obtained from Street design Limited. Apply the stain evenly, with brush strokes running parallel with the woodgrain, in thin layers, building up the finish as recommended by the stain manufacturer.

