

**AUTOMATIC FRAME**  
FOR RENOMAC PLUS UNITS

For the installation of the RenoMac Plus mattresses an automatic frame can be supplied whenever the installation conditions requires a ROV operated laying. The steel frame is equipped with a mechanical device in order to have a contemporary unhooking of the lifting loops.

The frame has been designed to operate in deep waters without divers, thus reducing the laying costs of the RenoMac Plus units.

The frame is CE marked in conformity to the Directive 2006/42/EC.

The dimensions of the frame (LxWxH) are:

6095x2200x2190 mm for transportation

6425x2570x2190 mm when equipped with safety lock, and handling bars.

Total weight: approx. 1600 kg.

Transport: by 40' open top container.

Load capacity: 20 t

28 Lifting points: 2x7 fixed and 2x7 openable hooks

The unhooking of the mattress is obtained by the pressure made by a ROV on a circular target whose resisting force can be set by a spring in order to meet the ROV's characteristics.

The release mechanism can be adapted to the mattress's weight through a mobile dead load.

The operating release function incorporates an easily operable safety lock to protect against inadvertent operations.

Protection bars are installed around the frame to prevent any damage to the release mechanism during deployment and recovery of the frame.

A system of handles allows the ROV to move the frame in order to increase the precision of the laying.

A set of slings, whose number depends on the RenoMac Plus unit size, allows to get the most proper distance between the frame and the mattress required for the ROV manoeuvrability.

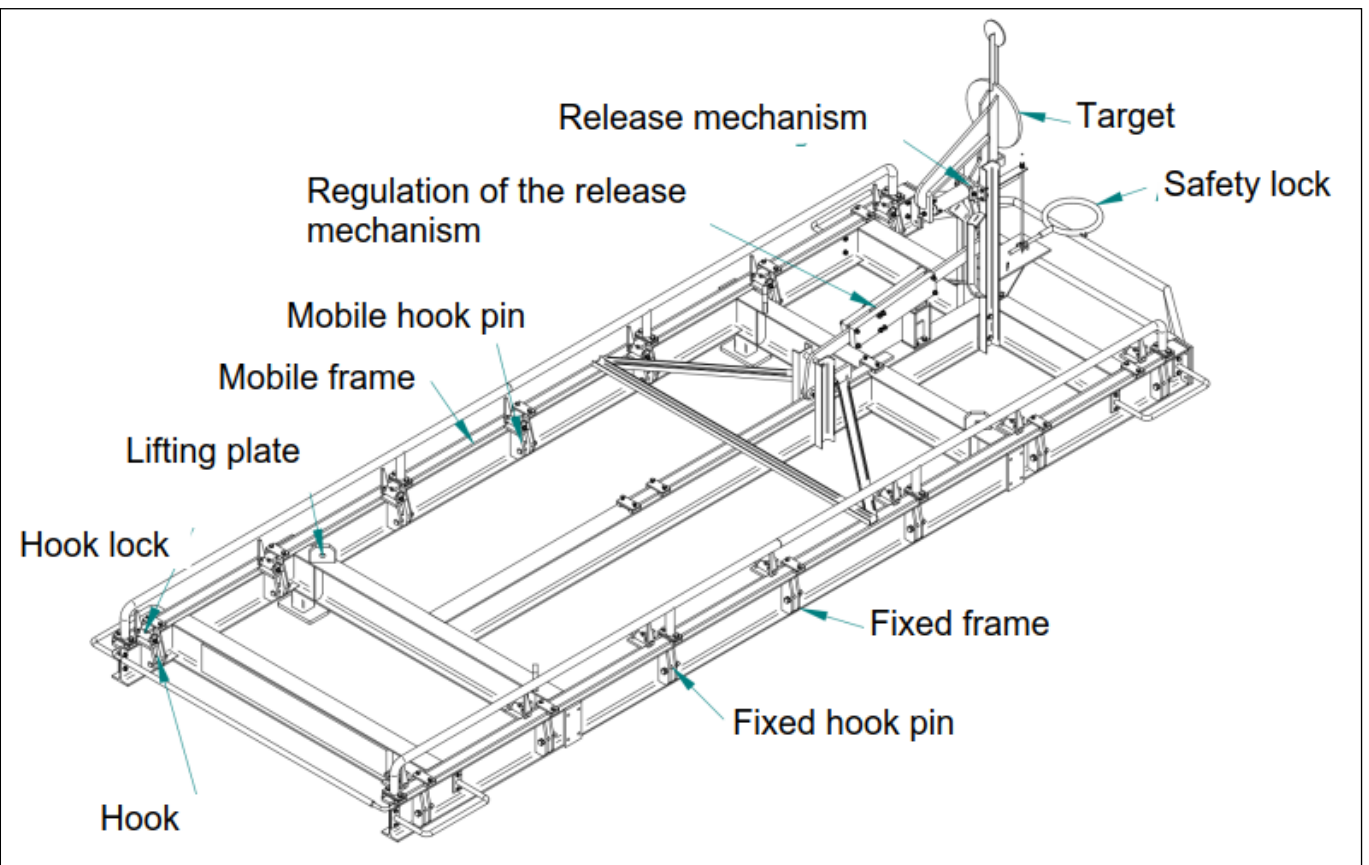

Figure 1: General view and frame components

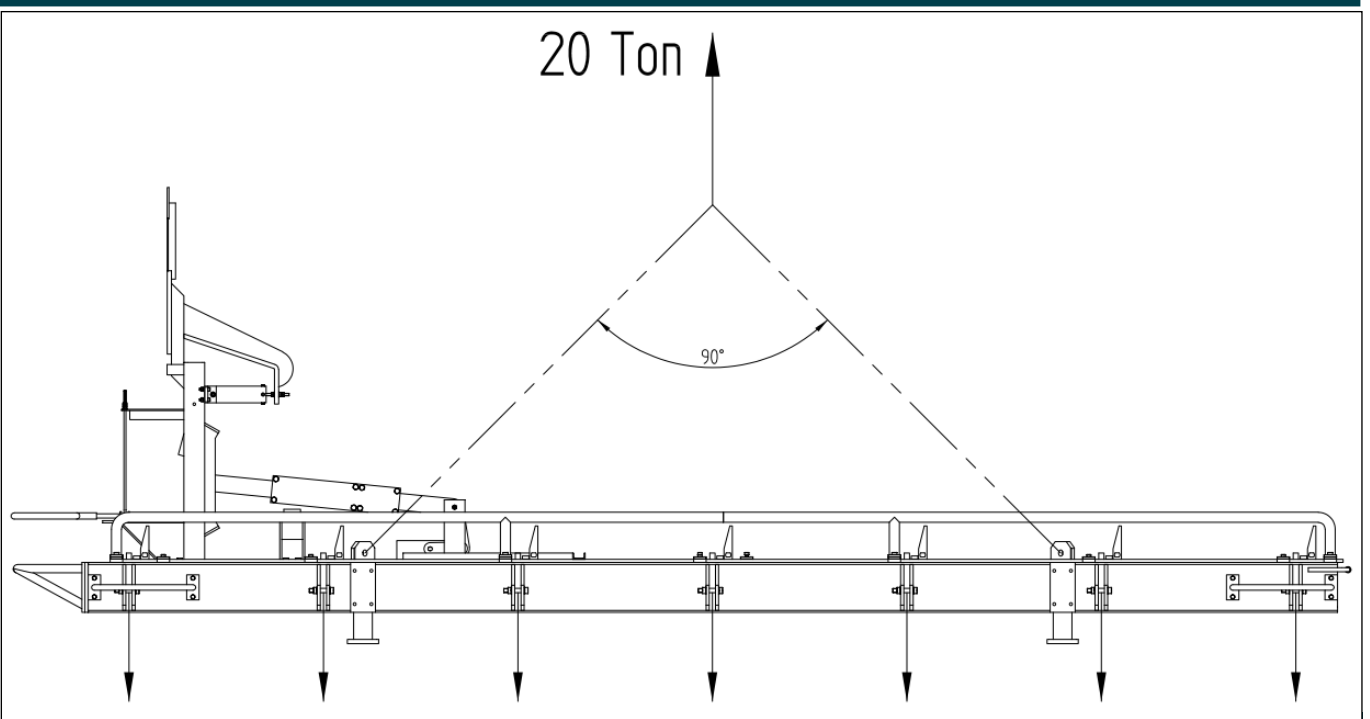

Figure 2: Loading configuration

## RIGGING

The standard rigging equipment includes the lifting devices needed for the frame-to-mattress hooking, whose configuration depends on the size of the RenoMac Plus unit.



Figure 3: The lifting frame operating with a RenoMac Plus unit before (left) and after (right) releasing the hooks

© Maccaferri Ltd. All rights reserved. Maccaferri will enforce Copyright.

**Maccaferri Ltd:**

T: (+44) 1865 770555

[www.maccaferri.com/uk](http://www.maccaferri.com/uk)

**Rep of Ireland:**

T: (+353) 18851662

[www.geostrong.net](http://www.geostrong.net)

**Specialist areas:**

Sales:

Technical:

Construction:

E: [sales.uk@maccaferri.com](mailto:sales.uk@maccaferri.com)

E: [technical.uk@maccaferri.com](mailto:technical.uk@maccaferri.com)

E: [construction.uk@maccaferri.com](mailto:construction.uk@maccaferri.com)

