

Scooter Rack BXMW/SCO



Standard Unit Dimensions:

Height: 800mm

Single Sided Capacities:

960mm (9 Scooters)

1050mm (10 Scooters)

Double Sided Capacities:

960mm (18 Scooters)

1050mm (20 Scooters)

Colours/Finishes:

Galvanised Only	RAL 9006 White Aluminium	RAL 7016 Anthracite Grey
BS 4800 10 A 07 Nimbus Grey	RAL 3020 Traffic Red	RAL 9005 Jet Black
BS 4800 14 C 39 Holly Green	RAL 1023 Traffic Yellow	BS 4800 00 A 05 Goose Grey
RAL 5015 Mid Blue	RAL 5013 Dark Blue	RAL 9016 Traffic White

The colours shown are a guide only.
Please check a colour chart to see the actual colour.

Product Information

The Scooter Rack can be single sided or double sided and can be manufactured to any size or length.

Features

- Users own padlock and chain
- Single sided or double sided options
- Hot dipped galvanized to BS EN ISO 1461:2009
- Powder Coating Available
- Baseplated as standard

Materials Used

- Framework - Mild Steel

Finish Options

- Galvanised to BS EN ISO 1461:2009
- Galvanised to BS EN ISO 1461:2009 & Polyester Powder Coated

Broxap Limited, Rowhurst Industrial Estate, Chesterton, Newcastle-under-Lyme, Staffordshire, ST5 6BD T: 01782 564411 E: info@broxap.com W: www.broxap.com



ISO 9001
Quality Management Systems
CERTIFIED

ISO 14001
Environmental Management
CERTIFIED

ISO 45001
Occupational Health and Safety Management
CERTIFIED



Scooter Rack BXMW/SCO

Guarantees, Warranties, Design-Life and Life-Expectancies

- 34 year (min) life expectancy for Hot Dip Galvanizing
- 8-10 year life expectancy on standard powder coatings
- 10-15 year life expectancy on Duplex (Zinc Coated) powder coatings
- 12 months' warranty* on parts & labour

*Maintenance and other qualifying criteria apply

Options

- Single sided or double sided options
- Polyester powder coating to RAL and BS colours

Diagram

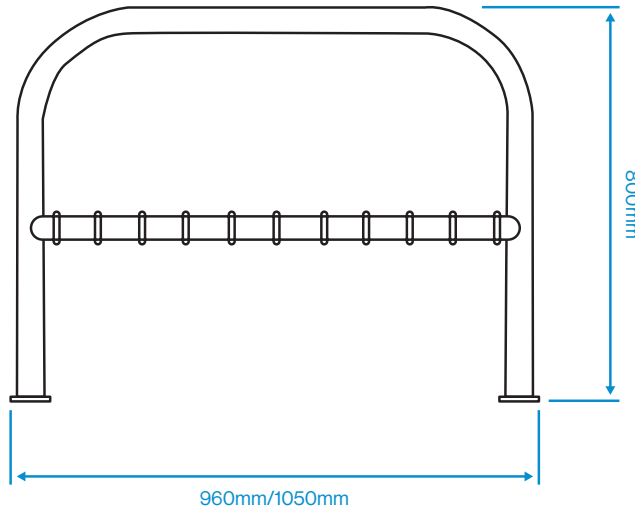

Standard Unit Dimensions:

Height: 800mm

Single Sided Capacities:

960mm (9 Scooters)

1050mm (10 Scooters)

Double Sided Capacities:

960mm (18 Scooters)

1050mm (20 Scooters)

Colours/Finishes:

	 RAL 9006 White Aluminium	 RAL 7016 Anthracite Grey
 BS 4800 10 A 07 Nimbus Grey	 RAL 3020 Traffic Red	 RAL 9005 Jet Black
 BS 4800 14 C 39 Holly Green	 RAL 1023 Traffic Yellow	 BS 4800 00 A 05 Goose Grey
 RAL 5015 Mid Blue	 RAL 5013 Dark Blue	 RAL 9016 Traffic White

The colours shown are a guide only.
Please check a colour chart to see the actual colour.

Broxap Limited, Rowhurst Industrial Estate, Chesterton, Newcastle-under-Lyme, Staffordshire, ST5 6BD T: 01782 564411 E: info@broxap.com W: www.broxap.com



ISO 9001
Quality
Management
Systems
CERTIFIED

ISO 14001
Environmental
Management
CERTIFIED

ISO 45001
Occupational
Health and Safety
Management
CERTIFIED

