

## Bracknall Cycle Stand BXMW/BRA



### Standard Unit Dimensions:

Width: 950mm  
Height: 750mm  
Diameter: 50mm  
Capacity: 2 Cycles

### Colours/Finishes:

Galvanised Only	RAL 9006 White Aluminium	RAL 7016 Anthracite Grey
BS 4800 10 A 07 Nimbus Grey	RAL 3020 Traffic Red	RAL 9005 Jet Black
BS 4800 14 C 39 Holly Green	RAL 1023 Traffic Yellow	BS 4800 00 A 05 Goose Grey
RAL 5015 Mid Blue	RAL 5013 Dark Blue	RAL 9016 Traffic White

The colours shown are a guide only.  
Please check a colour chart to see the actual colour.

## Product Information

The Bracknall Cycle Stand is a tubular cycle stand available with or without integral information panel and three bands of reflective tape.

## Features

- Hot dipped galvanised to BS EN ISO 1461:2009
- Available with or without integral information panel and three bands of reflective tape
- Complements any external environment
- Available root fixed or baseplated

## Materials Used

- Framework - Mild Steel

## Finish Options

- Galvanised to BS EN ISO 1461:2009
- Galvanised to BS EN ISO 1461:2009 & Polyester Powder Coated
- Stainless Steel Grade 304
- Stainless Steel Grade 316
- Duracast™ Polyurethane

Broxap Limited, Rowhurst Industrial Estate, Chesterton, Newcastle-under-Lyme, Staffordshire, ST5 6BD T: 01782 564411 E: info@broxap.com W: www.broxap.com



ISO 9001  
Quality Management Systems  
CERTIFIED

ISO 14001  
Environmental Management  
CERTIFIED

ISO 45001  
Occupational Health and Safety Management  
CERTIFIED



### Guarantees, Warranties, Design-Life and Life-Expectancies

- 34 year (min) life expectancy for Hot Dip Galvanizing
- 8-10 year life expectancy on standard powder coatings
- 10-15 year life expectancy on Duplex (Zinc Coated) powder coatings
- 12 months' warranty\* on parts & labour

\*Maintenance and other qualifying criteria apply

### Options

- Available in Duracast™ Polyurethane (PU) or Galvanised & Polyester Powder Coated
- Available Base Plated or Submerged Fixing
- Available with or without tapping bar, reflective bands and stickers

### Diagram

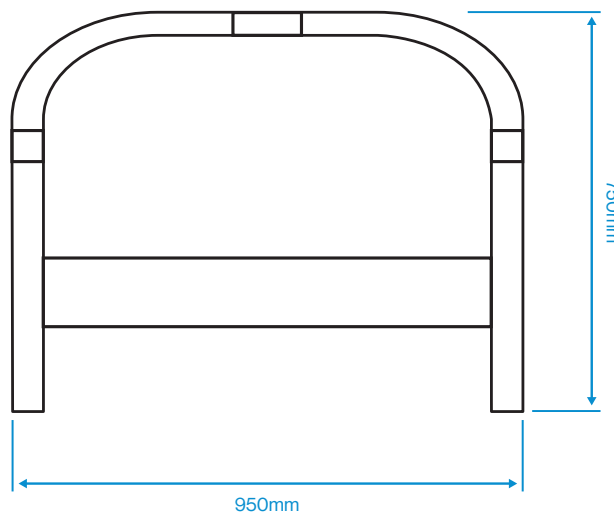

#### Standard Unit Dimensions:

Width: 950mm  
Height: 750mm  
Diameter: 50mm  
Capacity: 2 Cycles

#### Colours/Finishes:

Galvanised Only	RAL 9006 White Aluminium	RAL 7016 Anthracite Grey
BS 4800 10 A 07 Nimbus Grey	RAL 3020 Traffic Red	RAL 9005 Jet Black
BS 4800 14 C 39 Holly Green	RAL 1023 Traffic Yellow	BS 4800 00 A 05 Goose Grey
RAL 5015 Mid Blue	RAL 5013 Dark Blue	RAL 9016 Traffic White

The colours shown are a guide only.  
Please check a colour chart to see the actual colour.

Broxap Limited, Rowhurst Industrial Estate, Chesterton, Newcastle-under-Lyme, Staffordshire, ST5 6BD T: 01782 564411 E: info@broxap.com W: www.broxap.com



ISO 9001  
Quality Management Systems  
CERTIFIED

ISO 14001  
Environmental Management  
CERTIFIED

ISO 45001  
Occupational Health and Safety Management  
CERTIFIED

