

Andromeda Concrete Planter BX27 2065



Standard Unit Dimensions:

Rectangular:
Length: 1700mm
Width: 500mm
Height: 500mm
Weight: 420kg

Concrete Colours/Finishes:

Acrylic Paint:

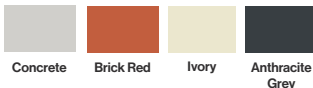

Natural Concrete:

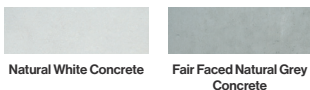

Polished Reconstructed Stone:

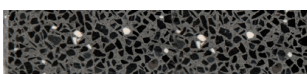

Black Stone

The colours shown are a guide only.
Please check a colour chart to see the actual colour.

Product Information

Andromeda Concrete Planters can be used as decorative elements of street furniture as well as access control. These dual purpose units share the same smooth surface as their bench counterparts. You can therefore suit any space whilst also matching the surrounding seating; there are various colours and proportions available.

Features

- Holes for water drainage in the planter base.
- Manufactured with two concrete supports in the base.
- Four different proportions/sizes available.

Materials Used

- Concrete

Options

- Other sizes & configurations available: Mid square - 1150mm L x 1150mm W x 800mm, Low square - 800mm L x 800mm W x 800mm, Large rectangular - 2000mm L x 500mm W x 500mm H
- Available in natural-look concrete or polished stone.
- Available in standard acrylic paints: brick red, ivory, and concrete.

Broxap Limited, Rowhurst Industrial Estate, Chesterton, Newcastle-under-Lyme, Staffordshire, ST5 6BD T: 01782 564411 E: info@broxap.com W: www.broxap.com



Diagrams

Andromeda Low Square

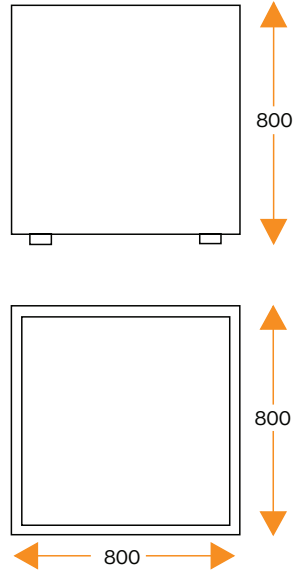

Andromeda Mid Square

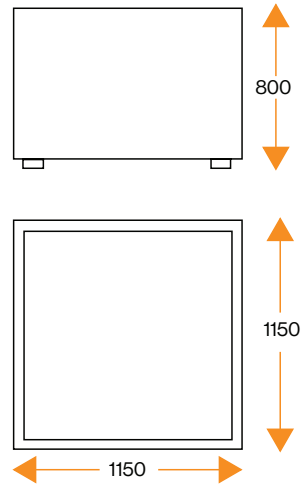

Andromeda Rectangular

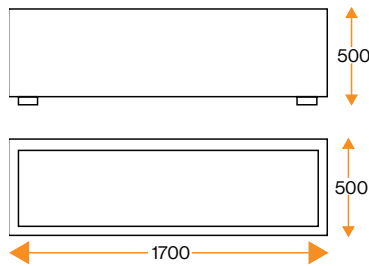

Andromeda Large Rectangular

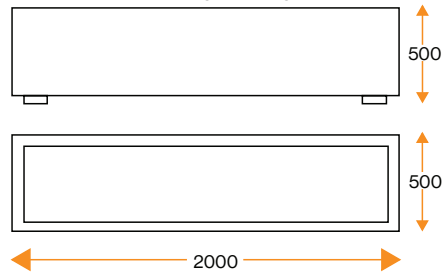

Standard Unit Dimensions:

Rectangular:
 Length: 1700mm
 Width: 500mm
 Height: 500mm
 Weight: 420kg

Concrete Colours/Finishes:

Acrylic Paint:

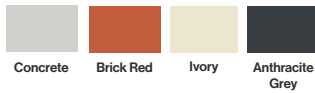

Natural Concrete:



Polished Reconstructed Stone:

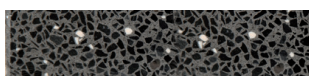

Black Stone

The colours shown are a guide only.
 Please check a colour chart to see the actual colour.

Installation

Surface Mounted Planter



Broxap Limited, Rowhurst Industrial Estate, Chesterton, Newcastle-under-Lyme, Staffordshire, ST5 6BD T: 01782 564411 E: info@broxap.com W: www.broxap.com

