



ACO MultiDrain[®] MD

Medium duty channel drainage system

Product Catalogue



ACO MultiDrain® MD

MultiDrain is high performance channel drainage system, with a wide range of grates to suit both traditional and contemporary installations, including discreet slot drainage. This range offers strength, performance and impressive aesthetics.

ACO MultiDrain® M100

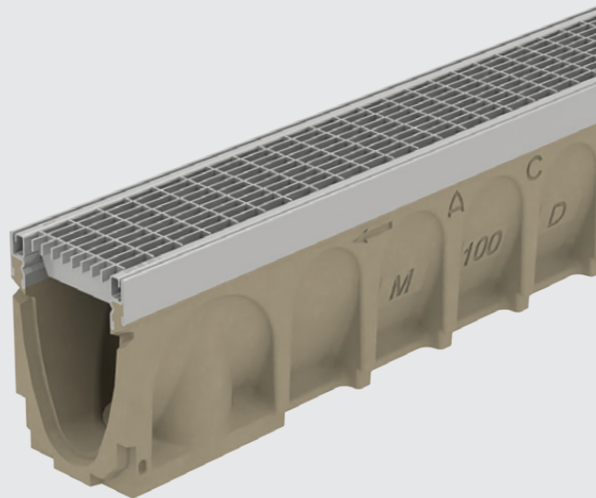

ACO MultiDrain® M150

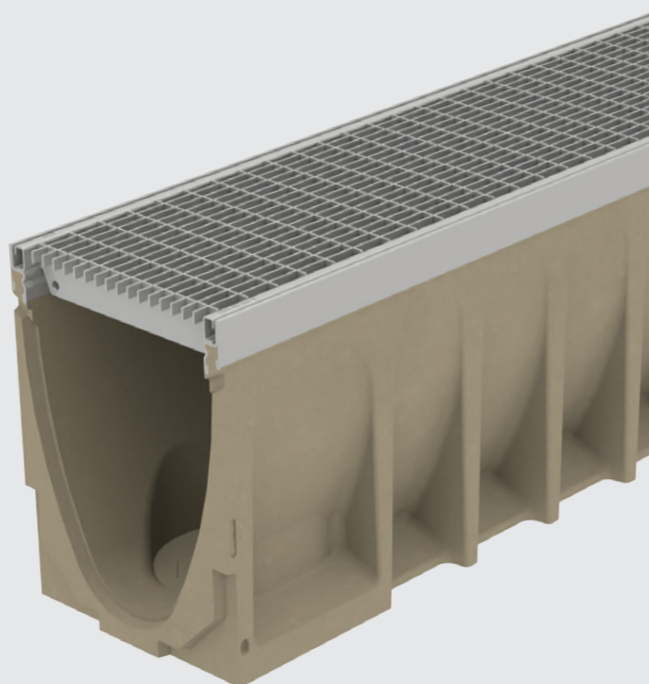
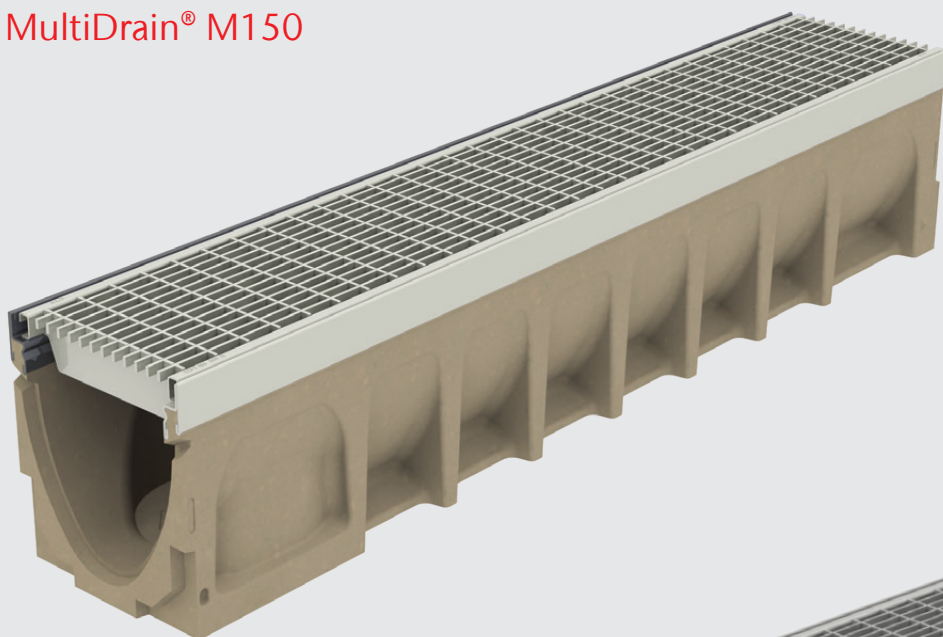

ACO MultiDrain® M200

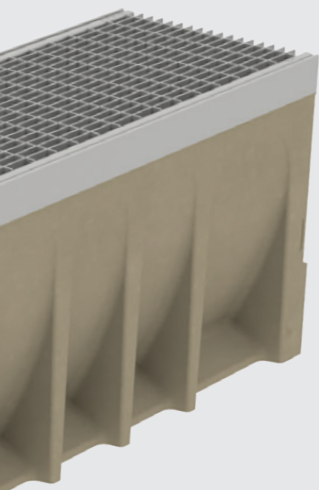
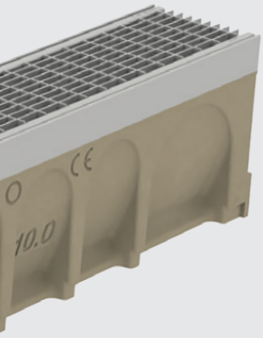

ACO. creating the future of drainage 4

[ACO Technologies plc](#)

[ACO Water Management](#)

Water protection and rainwater management

[What is ACO MultiDrain®?](#) 6

[ACO MultiDrain® features overview](#) 8

[ACO MultiDrain® MD range layout](#) 10

[A range of solutions with ACO MultiDrain®](#) 12

[Explore ACO's large range of grating styles](#) 14

[Surface design detail](#) 17

[Design Support Service](#) 18

[ACO BIM Models](#)

[ACO QuAD Hydraulic Design Software](#) 19

[Installation detail](#) 20

[Chemical resistance chart](#) 24

ACO MultiDrain® channels with UltraSTEEL galvanised edge rails 26

[ACO MultiDrain® MD channels](#) 27

[ACO MultiDrain® MD components](#) 29

Gratings for use with ACO MultiDrain® channels with UltraSTEEL galvanised edge rails 35

ACO MultiDrain® channels with stainless steel edge rails 44

[ACO MultiDrain® MD channels](#) 45

[ACO MultiDrain® MD components](#) 48

Gratings for use with ACO MultiDrain® channels with stainless steel edge rails 51

[Channel footpath drainage](#) 59

[ACO Downpipe connectors for use
with the MultiDrain® systems](#) 62

[Preparing the system for installation](#) 63

[ACO Drainlock™ Gratings](#) 68

[Maintenance of ACO MultiDrain®](#) 70

Further Learning 72

[ACO Professional Development](#)

[Case Studies](#)

[Colab](#)

ACO. we care for water

ACO is a Water-Tech company that protects water. Building on our global drainage expertise that protects people from water, we increasingly see our mission as also protecting water from people.

With the ACO WaterCycle, ACO provides systems that collect and channel, clean, retain and ultimately reuse water. In this way, ACO contributes to the preservation of clean groundwater as a vital resource, and makes a contribution to tomorrow's world. In its Agenda 2030, the UN global community set the improvement of water quality as one of 17 sustainable development goals.

Intelligent drainage systems from ACO increasingly use smart technology to ensure that rainwater and wastewater are drained, or temporarily stored. With innovative separation and filter technology, we prevent water contamination by pollutants such as fat and grease, fuels, heavy metals and microplastics.

Today, ACO goes one step further: we accept the challenge of reusing water, and thus establishing a resource-saving cycle. For all products and systems, ACO attaches great importance to durability, reusability and a low carbon footprint. The pursuit of sustainability is an ongoing process that we strive to meet every day.

The ACO Group is a global family business that is one of the world market leaders in the Water-Tech segment. Founded in Schleswig-Holstein in 1946, it operates as a transnational network in over 50 countries. Worldwide, ACO is characterised by a high level of decentralised ownership, and explicit regional market proximity.

www.aco.com



Holder
Iver and Hans-Julius Ahlmann



Headquarters of the ACO Group
in Rendsburg/Büdeltsdorf



5,200

employees in more than 47 countries (Europe, North and South America, Asia, Australia, Africa)

1 Billion

Euro Sales in 2021

37

production sites in 18 countries



ACO Academy
for practical training

Water protection and rainwater management

What is ACO MultiDrain® MD?

ACO MultiDrain® MD channel drainage system is manufactured from Vienite®, ACO's sustainable high strength material. It is available in three widths; 100mm, 150mm and 200mm, and has a variety of depths and slopes.



The channel units are certified to BS EN 1433: 2002 Load Class D 400* and form the main components of the system.

Depending on the load class and application requirement, a wide range of gratings are available to complete the system. You can now choose from a range of traditional and discreet slot drainage gratings, solid covers and cross footpath drainage units to ensure all applications are catered for.

All gratings within the system are fitted with ACO Drainlock™, a bar-less locking device which reduces the risk of blockage and improves hydraulic capacity. The mechanism also provides for easy installation and maintenance of the system.

As standard, channels are manufactured with UltraSTEEL™ protective edge rails. The UltraSTEEL™ rails, with their unique patented design, provide optimum channel protection and improved bonding between channel sides and the surrounding pavement material.



ACO MultiDrain® MD features overview



Anti shunt feature
holds grating
securely in place



ACO Drainlock™ gratings - this bar-less locking
device improves hydraulic capacity and provides for
quick and simple
installation of gratings

Sealant groove for simple
watertight installations

V shaped channel bore improves
speed of water flow and promotes
self cleansing

Male and female channel connections
to aid fast installation.

Improved knockout for connection to Ø110mm
(for M100D channels) and Ø160mm (for M150D
and M200D channels) PVC-U pipes.



Gratings

ACO MultiDrain® MD System has a wide variety of gratings available that include cast iron, stainless steel and plastic slotted gratings, heelguard options (including the new ATec coated heelguard grating), solid covers and brickslot gratings. See pages 35 to 43 and 51 to 58 for further details.

Load Classes



A 15
Pedestrian, cycleways, minimally trafficked areas (light domestic vehicles only).



B 125
Pedestrian precincts, light vehicles, private car parks and drives.



C 250
Parking areas, service stations (cars) and slow-moving light commercial vehicles.



D 400
Public highways, parking areas for all types of vehicles, distribution yards.

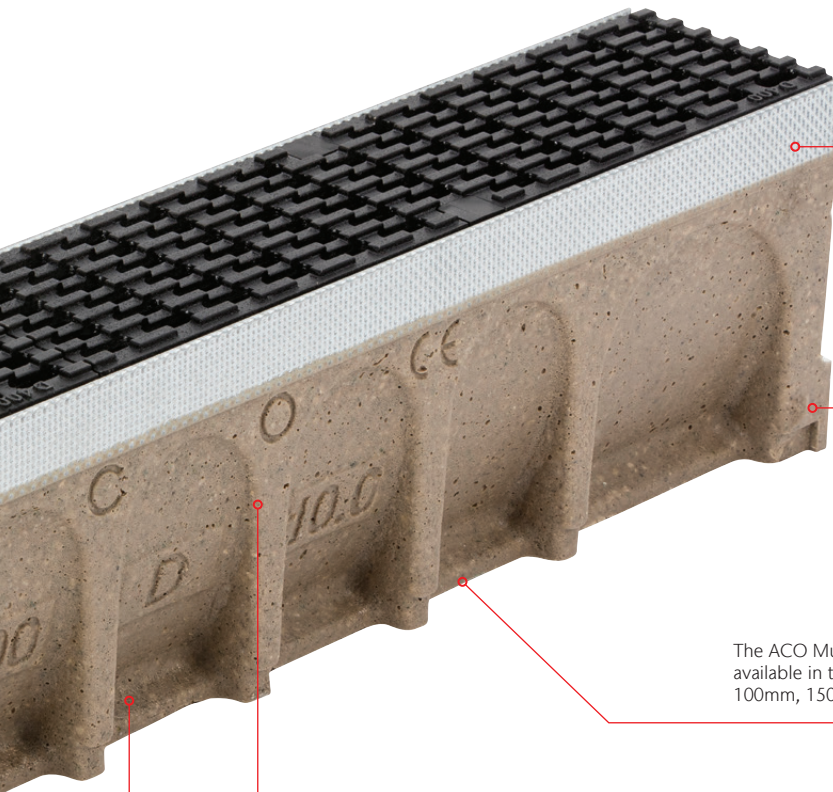

Protective UltraSTEEL™ galvanised edge rails for improved strength and bonding between channel and surface materials. Also available in stainless steel.

Manufactured from VieniTE®, a polymeric based recycled material, strong and lightweight design, improves stability and anchors product into concrete surround.



The ACO MultiDrain® MD system is available in three channel widths; 100mm, 150mm and 200mm.

Parking areas for all types of vehicles*

Internal channel marking for easy identification once installed.



Product features

- Provides an efficient drainage solution for a wide variety of applications
- Range of constant, sloped and shallow depth channels
- Caters for a range of catchment areas
- Strong and robust channel design
- CE and UKCA marked and BS EN 1433: 2002 certificated to Load Class D 400*
- Extensive choice of gratings and accessories for many applications
- Choice of outlet options, gullies, sumps or channel knockouts
- Lightweight design is simple and fast to install
- 100% recyclable**
- Ideal for use against building facades or as a Part M threshold drainage solution when used with ACO MultiDrain® Brickslot ST grating

* This system is not suitable for carriageways of public roads or motorways.

** Metal components are recyclable. VieniTE is recyclable, i.e. it can be collected, processed and returned for re-use as a raw material.

ACO MultiDrain® MD range layout

To support a wide variety of catchment depths, hydraulic capacities and applications, the system is available in three channel widths, 100mm, 150mm and 200mm and has a range of constant depths, shallow depth and sloping depth channels to suit the drainage design.

The layout below illustrates the channels and accessories available within the ACO MultiDrain® MD range and to aid product selection, a summary of the function and feature of each component is provided.

All ACO MultiDrain® MD channels can be purchased with galvanised or stainless steel edge rails. Further details can be found on pages 35 to 43 and 51 to 58 of this brochure.

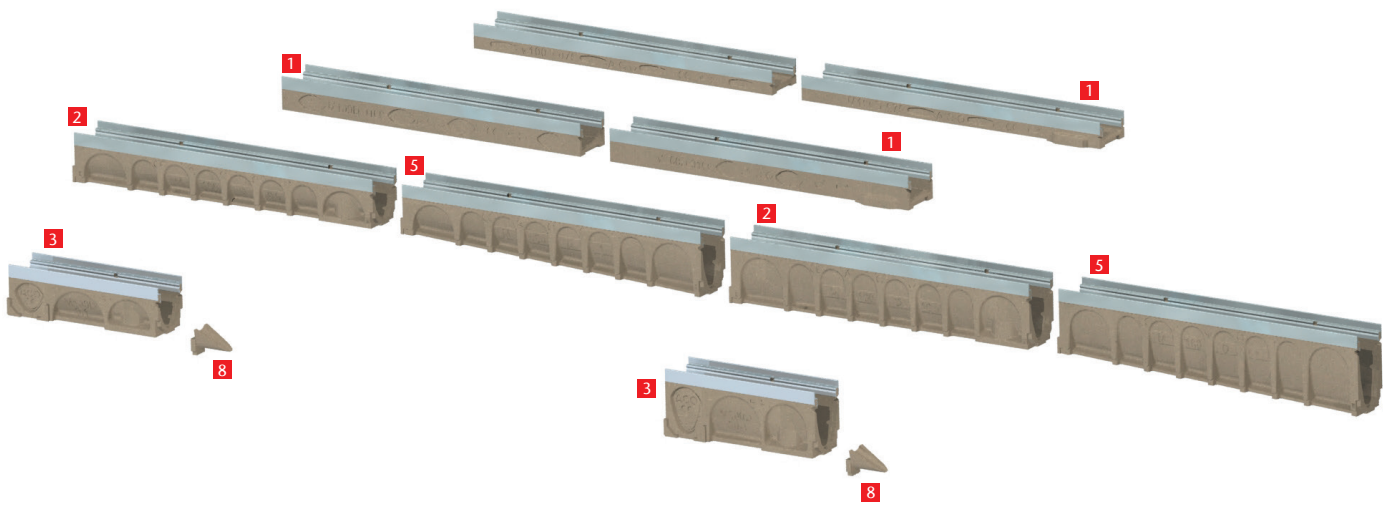

1 Shallow depth channels

- 100mm wide bore: Four shallow channel units are available in 1m lengths with an overall depth of 75mm or 100mm.
- 150mm wide bore: One shallow channel unit is available in 1m length with an overall depth of 100mm.
- 200mm wide bore: One shallow channel unit is available in 1m lengths with an overall depth of 100mm.

Standard option available includes vertical cast-in TPE seal for connection to Ø110mm pipework.

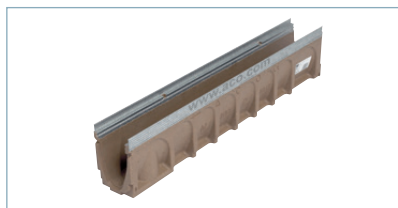

2 Constant depth channels

- 100mm wide bore: Four constant depth channel units are available in 1m lengths with overall depths ranging from 150mm to 300mm.
- 150mm wide bore: Three constant depth channel units are available in 1m lengths with overall depths ranging from 210mm to 310mm.
- 200mm wide bore: Three constant depth channel units are available in 1m lengths with overall depths ranging from 265mm to 365mm.

These channels include a vertical knockout for connection to Ø110mm (100mm wide bore channels) or Ø160mm (150mm and 200mm wide bore channels) pipework.



3 Constant depth channels - 0.5m

- 100mm wide bore: Four 0.5m constant depth channel units are available with overall depths ranging from 150mm to 300mm.
- 150mm wide bore: Three 0.5m constant depth channels with overall depths ranging from 210mm to 310mm.
- 200mm wide bore: Three 0.5m constant depth channels with overall depths ranging from 265mm to 365mm.

These channels include vertical knockout for connection to Ø110mm (100mm wide bore) or Ø160mm (150mm and 200mm wide bore) pipework and side knockout for 90° channel connections.



4 Universal sump

Each system width has one 0.5m Universal sump for connection to all channels. Outlet options for Ø110mm and Ø160mm pipes and foul air traps.

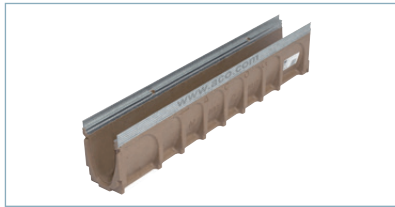

5 Sloping depth channels

100mm wide bore: Twenty 1m sloping channels with 0.5% fall in depths from 150mm to 250mm.



6 Universal gully

One Universal gully for all applications and channel widths from Load Class A 15 to D 400. Standard features include ductile cast iron cover, silt bucket and roddable foul air trap for connection to Ø160mm PVC-U pipe.



7 Multifunctional endcap

One plastic universal endcap for each channel width. Provides a closing or outlet option to Ø110mm (100mm wide bore channels) or Ø160mm (150mm and 200mm wide bore channels) pipes.



8 Step connector

A polymer concrete unit which helps provide smooth water transition between constant depth channels when used in a stepped system design. The Step connector is suitable for the 50mm step between each of the constant channel depths.

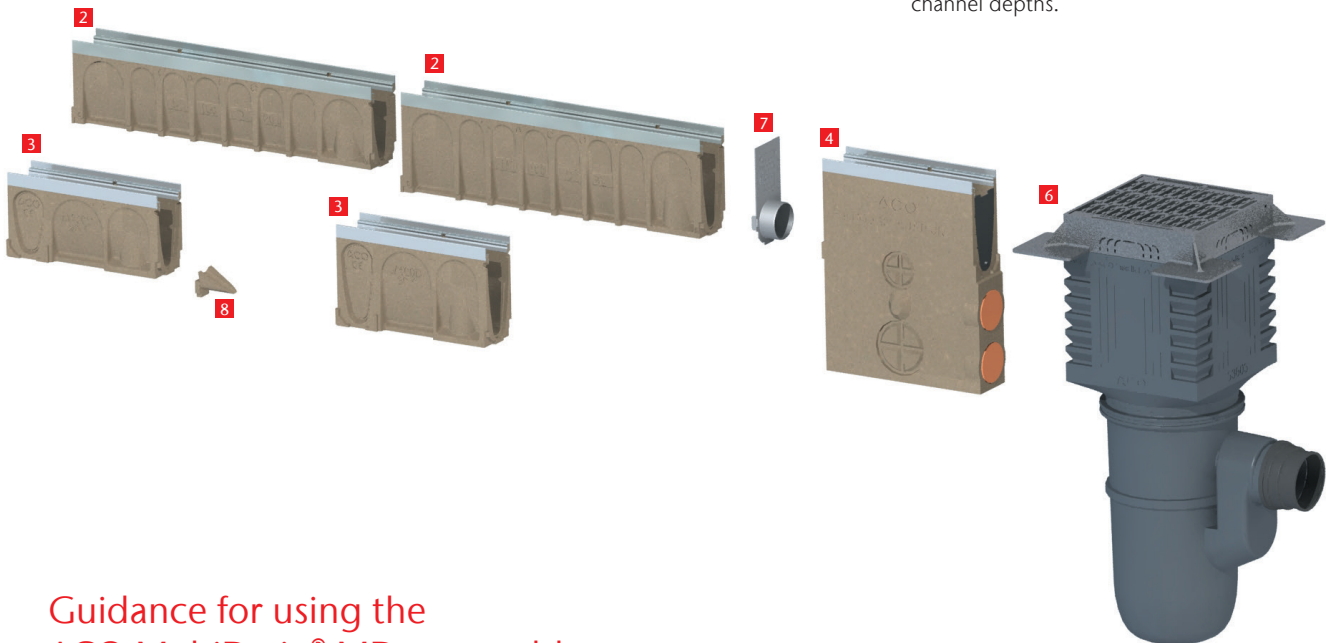

Guidance for using the ACO MultiDrain® MD parts tables

The ACO MultiDrain® MD parts tables are shown on the following pages. The product information is split down by channels widths and further by channel depth and edge rail type. This is to enable quick and simple product identification and selection.

The tables for ACO MultiDrain® MD channels list a number associated with the Invert Type. This number highlights the drainage design which can be achieved when using these channels. The key for the Invert channel types is shown below.

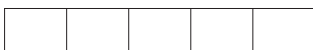

1 Constant Depth Invert

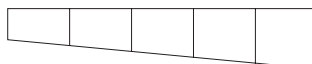

2 Sloping Invert

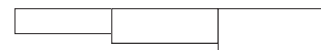

3 Stepped Invert

A range of solutions with ACO MultiDrain® MD



Curved installations

Creating a curved installation of drainage channel can create a more dynamic installation, and can be installed with traditional slotted grates or Brickslot ST style grates.

By slightly angling each channel the drainage line will progressively curve, with minimal additional gap on the surface. Creating this style of installation benefits from using shorter 500mm channels, and all channels should be sealed with an appropriate sealant.



Discreet styles with Brickslot ST

Modern urban landscapes wanting to achieve a sleek sophisticated aesthetic often opt for Brickslot ST or Twinslot gratings. These discreet grates are installed with MultiDrain channels under the installed surface, giving a 10mm slot between your chosen brick or slab. This gives an uninterrupted landscape without compromising on functionality.



Creative installations

ACO drainage channels including the MultiDrain range are used in creative urban environments, to create interactive water features or modern fountains. Either discreetly hidden using Brickslot ST or made into a featured edge, the channels are a practical and aesthetically pleasing solution for creating a water feature.



Shallow depth installations

Where installations have depth restriction, such as train platforms or raised walkways, MultiDrain shallow channels can be installed. Two depths are available in M100D/DS which are 75 and 100mm deep. Both M150D/DS and M200D/DS have one shallow channel 100mm deep.

These channels are compatible with the full range of MultiDrain grates, giving flexibility in selection and installation.



Curtilage drainage

Both grated and Brickslot ST ranges can be installed near the curtilage of the building, being both functional and adding to the aesthetics of the building.

It is popular to install galvanised or stainless steel grates in visible public areas near the curtilage; and buildings with modern reflective surfaces look especially elegant.



Public areas and car parks

MultiDrain is a reliable choice for public areas and car parks. It's wide selection of A 15 to D 400 load class grates, Heelguard and non-Heelguard options and a selection of material choices make this a versatile range.

The Drainlock feature securely attaches the grate to the channel, and anti-shunt features and robust channel edges make this a sensible choice for demanding areas.

Explore ACO's large range of grating styles

Style, aesthetics, performance and reliability are all important factors when specifying surface water management systems. Globally recognised as the no. 1 choice in managing surface water, ACO provide designers with the widest range of channel and grating styles to choose from.

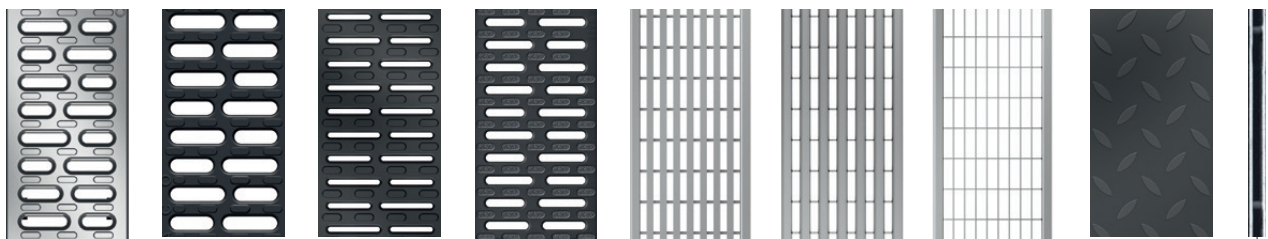

Multiple applications provided for by ACO MultiDrain® MD

The breadth of the ACO MultiDrain® grating range provides designers with a wide choice of styles to complete their surface water drainage system.

Depending on the application requirement, Architects, Designers and Planners can choose from variety of popular, long establish designs in ductile iron, high tech composites, galvanised or stainless steel materials.

For applications which require discreet drainage to blend subtly with the design of the landscape, ACO Brickslot ST can provide an aesthetically-pleasing finish.

Supplied as standard with ACO Drainlock™ boltless locking, the range of grating styles is available in load classes A 15 – D 400 making them the idea choice for both pedestrian and vehicular applications.

To suit a range of hydraulic requirements, these grating styles are available for use with 100mm, 150mm and 200mm wide channels.



Lighting & bespoke solutions



Lighting Solutions

Enhance and add definition to a space. See ACO Lighting Systems brochure for details.



Bespoke Slot Solutions

Our Brickslot ST gratings can be provided in a range of bespoke heights and widths. Contact our Design Services Team for details.



Bespoke Freestyle Solutions

Realise your own design ideas. ACO Freestyle cast iron gratings offer you individual solutions for every project. Contact our design services team for more details.

Grating styles

A range of contemporary and traditional, elegant designs will add character and style to any landscape project.

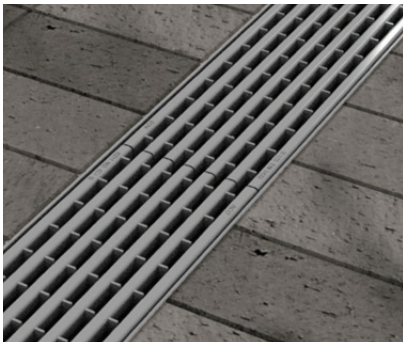

Intercept Profile Stainless steel

High quality linear profile design provides a contemporary, long lasting finish to any prestigious landscaping project.

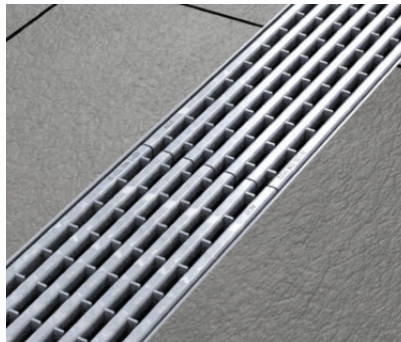

Intercept Profile Galvanised steel

High quality linear profile design provides a stylish option for those looking for an alternative to stainless steel.



Intercept Bar

The sleek and elegant intercept bar design provides a classic, high end finish to any project.

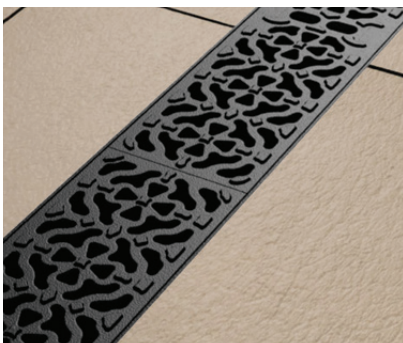

Mosaic

The unique pattern of the Mosaic design provides an ideal finish to heritage or traditional landscapes.

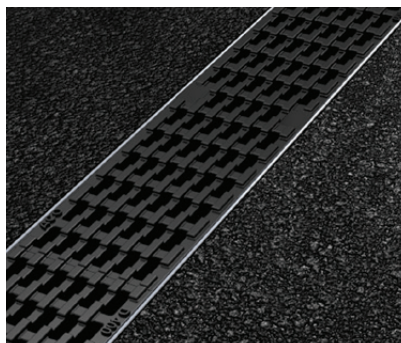

Intercept

The Intercept D400 grating provides a minimalistic and widely appealing design.

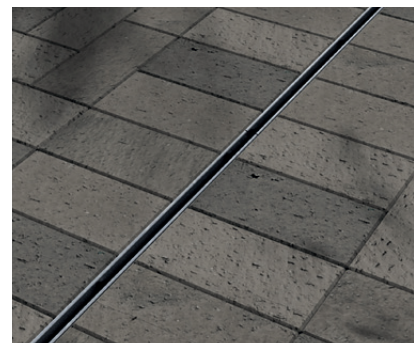

BrickSlot ST

The ultimate discreet drainage grate perfectly suited for harmoniously blending into block paving.



Surface design detail

MultiDrain MD channels are compatible with a wide range of grating designs including a bespoke grating service from ACO.



The ACO Freestyle offering is a unique customer-led grating design solution, which gives you the freedom to create fully bespoke drainage grating designs for the external environment.

Freestyle is relevant for clients who value first impressions – which starts with the approach to the building.

It is for clients who value something new being brought to the table and bespoke drainage gratings are something most clients have not considered. When looking at pedestrian areas with quality paving solutions, Freestyle is a complimentary and functional aesthetic solution.

Clients, who value branding opportunities, will appreciate the possibilities of incorporating their logo into the grating design.

Freestyle also works for those clients who are aiming for a traditional standing or wish to integrate into a historic setting, as the flowing forms of metal translate well when recreating Victorian grandeur.

For more information and templates visit www.aco.co.uk/products/freestyle



Design support services

Surface water management system design can often be a complex task. Success in combining products and processes requires a thorough understanding of how these different elements work together.

The ACO Design Services Team is able to work closely with you through the entire design process to ensure accurate and cost-effective product selection is made.

Services we offer include (free and without obligation):

- Whole system design, from collection to the attenuation of surface water
- Hydraulic calculations and AutoCAD detailing
- Parts schedules

ACO has embraced the concept of value engineering as an approach to on-site construction that saves both time and money.

ACO will review any design to minimise the total scheme and life cost of a proposal. The team can suggest the most appropriate range depending on your requirements.

Some ranges like MultiDrain or MonoDrain allow water to be contained and conveyed close to the surface, which accords with the principles advocated for Sustainable Drainage (SuDS Manual, 2015), by removing the need for pumping. Other ranges like Qmax allow attenuation – the storage of large volumes of water during storm events, reducing overall site costs.

For detailed designs using the ACO Hydraulic Design Software, please contact the ACO Water Management Design Services Team.

If manual calculations are preferred to using our QUAD software, hydraulic tables and instructions for manual calculations can be provided.

For design enquiries go to www.aco.co.uk/engineered-solution-design-services

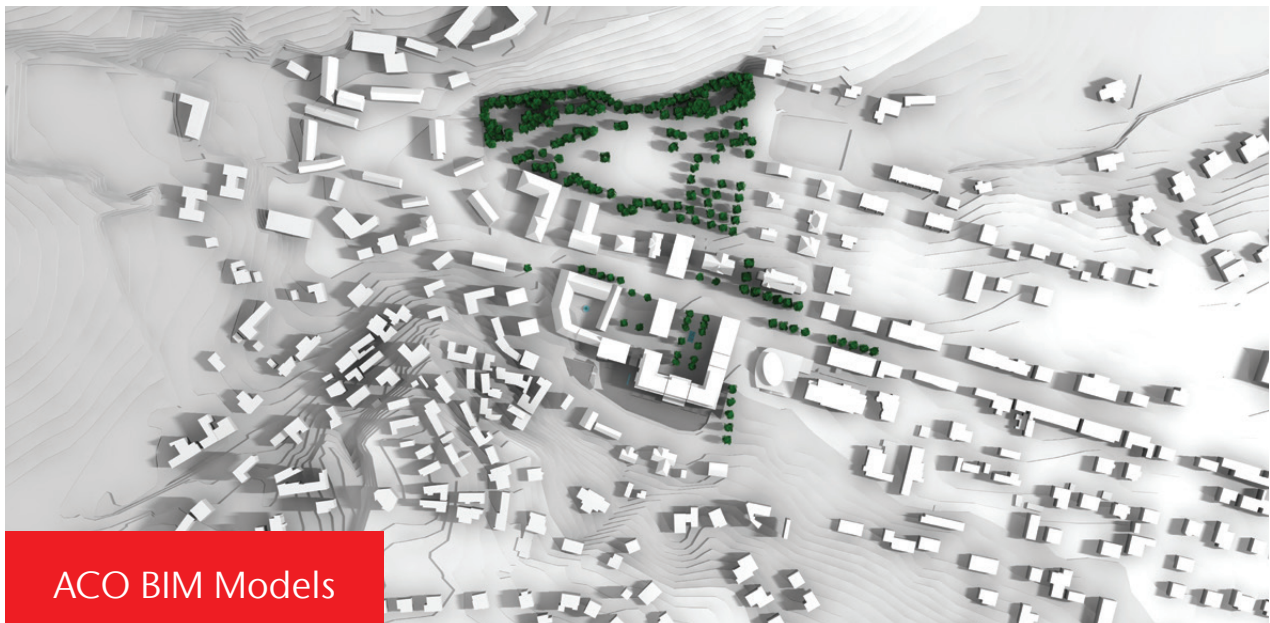

ACO BIM Models

BIM is the process of generating and managing data, and developing collaborative behaviours that will unlock new and more efficient ways of working at all stages of the project life-cycle.

These files will help contractors specify and optimise drainage systems in line with the overall benefits of BIM-

enabled working, including faster project delivery, reduced costs, reduced waste and greater project predictability.

Depending on the product range Civils3D, IFC or Revit files are available for download.

www.aco.co.uk/aco-bim-models

ACO QuAD Hydraulic Design Software

Try our free design tool



The free-to-use ACO QuAD Hydraulic Design software has unprecedented levels of choice and flexibility built-in, to enable the efficient and accurate hydraulic design of any surface water management scheme.

The hydraulic engine has been robustly tested and is the tool used by ACO's own internal Design Services team in modelling surface water solutions for customers.

ACO QuAD Hydraulic Design software uses differential equations for spatially varied flow that online alternative solutions cannot accurately match. For example the Manning's equation for steady uniform flow does not work with level channels and is grossly inaccurate on shallow gradients.

Here are some of the features it includes:

- Powerful project-based software
- Create catchment models that are fully editable
- PDF summary document output
- Cloud based – All designs are stored securely on our server against your login
- Integrated rainfall data for the whole of the UK

To use the QuAD Hydraulic Design software visit: www.aco.co.uk/quad-hydraulic-design-2.0

QuAD Features Overview

Cloud based

The software means increased efficiency providing design resources you need when you need it, allowing you to deploy the same design capability consistently, with the same consistency in results every time.



Flexible catchment design

QuAD is designed to support designers in the creation of catchment areas. Supplementary catchment areas can easily be added upstream and downstream of any previously designed channel run.



Product + value optimiser

Optimising the specific channel runs can be done with the optimiser feature selecting the smallest product suitable. Excavation and concrete requirements are also provided.



Attenuation assessments

Calculate the attenuation required for the project and compare it with the storage available in the channel design. Attenuation volume is presented along with suitable options for storage.



Flexible download format

Output can be generated for all or parts of the project and can be generated in pdf or CSV formats.



Application

Application selection ensure designers are able to get quick and accurate guidance in selection of the most suitable products based on the type of application the catchment is to cater for.



Rainfall assist

Rainfall intensity by location matters in design. QuAD provides a site locator map enabling the most accurate intensity to be input.



Resilience assessment

By inputting anticipated sedimentation rates and sedimentation density the QuAD software enables the designer to test their suggested maintenance schedules.



Secure scheme filing

All designs created by registered users are stored on a secure server and are password protected. Past projects are easily retrieved from the personalised menu.



Fully supported

There is support available either through a query submission or through self-help made possible by the comprehensive Knowledge database.



Installation detail

Load class

Installation recommendations shown are ACO minimum recommendations for BS EN 1433:2002 load class requirements.

Ground conditions

The long term performance of a channel installation to sustain vertical and lateral loads depends upon:

- A) Ground conditions
- B) Stability of the adjacent pavement
- C) A durable concrete bed and surround

The recommended installation detail may require the minimum dimensions to be revised to achieve site specific load class requirements.

Cutting and jointing

Mitre joints are formed by cutting the channels to the required angle and butting them together with the appropriate sealant (e.g. Sikaflex 11FC or similar) or ACO Repair Kit. Where possible 90° joints and T's should be formed so that gratings do not have to be cut. Angles can be formed by connecting them using proprietary PVCu pipework attached to the ACO inlet/outlet end caps. For further details please contact ACO Design Services Team.

Note: For load classes higher than C 250, mitred joints are not recommended in vehicular areas. Where requested ACO can custom manufacture angled joints to order.

Isolation joints

The channel must be isolated from the surrounding environment. An isolation joint must be positioned up to 1500mm from the channel wall. Any dowel bars must be located no nearer than 150mm from the channel wall. Other isolation joints in surrounding slab must be continued through the channel. Additional crack control may be required to comply with specifier requirements.

Installation into in-situ slab

Where a channel is to be installed into an existing concrete slab it is necessary to cut a suitably sized pocket in the slab. The channel will then need to be bedded in polymer modified mortar of 25mm minimum thickness (this may vary depending on the type of mortar used). Engineering advice may be necessary.

Temporary installation

A channel installation is not complete until the final surfacing is laid. In any temporary condition, i.e., the channel walls projecting above adjacent ground, site traffic should not cross channels. Loose boards, stone fill or cover plates will not protect the channel walls or grating. A temporary channel crossing should be formed by raising the ground level locally, to 3-6mm above top of edge rail, either side of a channel for a distance of 750 to 1000mm, to form ramps. Note that the channel load class should be adequate to carry the site traffic.

Block pavements

The channel must be supported laterally. Blocks laid directly against a channel must be laid as a soldier course and restrained from movement by bedding securely on the concrete haunch e.g. by using a polymer modified mortar for bed and perpendicular joints (e.g. RONAFIX mortar mix C or similar). Alternatively, extend concrete haunch up to finished paving level (as depicted in Option 2). Blocks or slabs bedded on sand remote from the channel should be set at a higher level to compensate for possible settlement of the paving in service.

Grate locking system

Gratings should be securely fixed to the channel, where required, using an appropriate grate lock system (where available).

Concrete surround dimensions

		Load Class			
		A 15	B 125	C 250	D 400*
Minimum Dimensions (mm)	X	100	150	150	200
	Y	Full channel height (less Y2 where necessary)			
	Z	100	150	150	200
	Y2	35	35	35	35
Maximum Dimensions (mm)		35	35	35	35
Asphalt pavement only	Y3	100	60	60	60

*E.g.. Parking areas for all types of road vehicle. Not suitable for carriageways of public roads or motorways.

Channels with traditional gratings

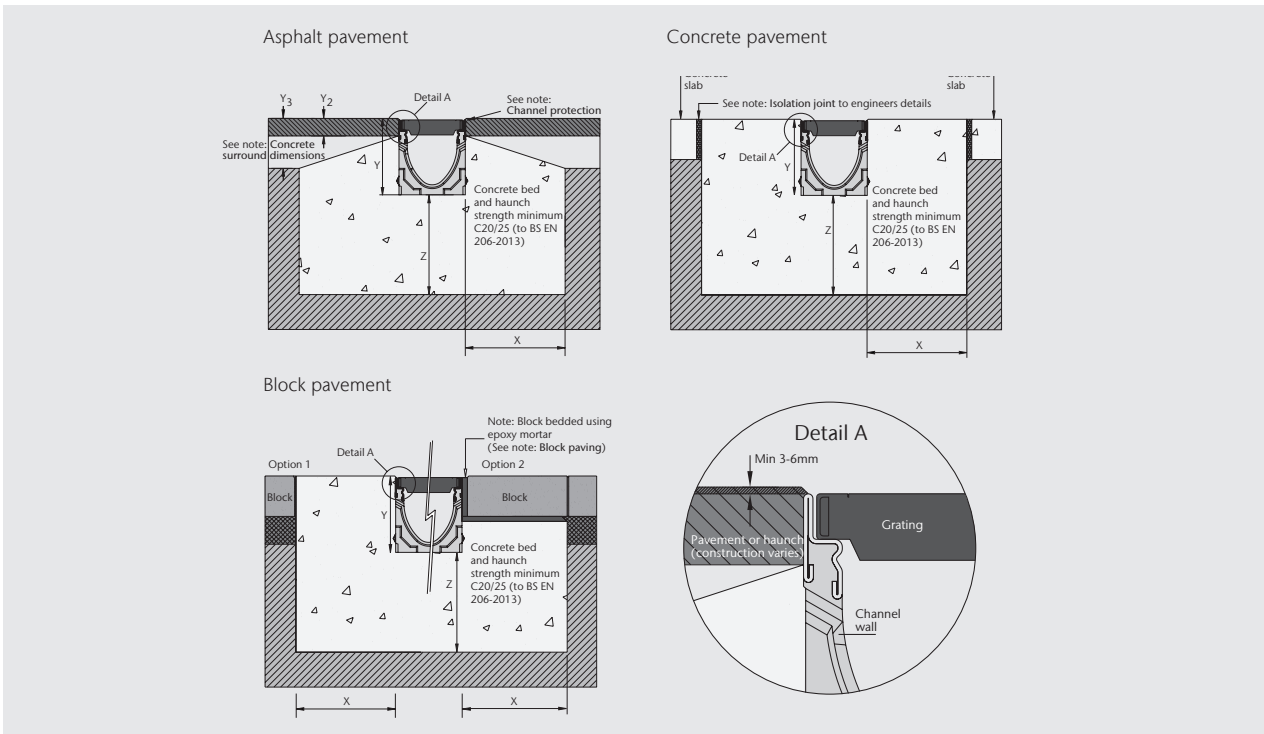

Channels with Brickslot ST gratings

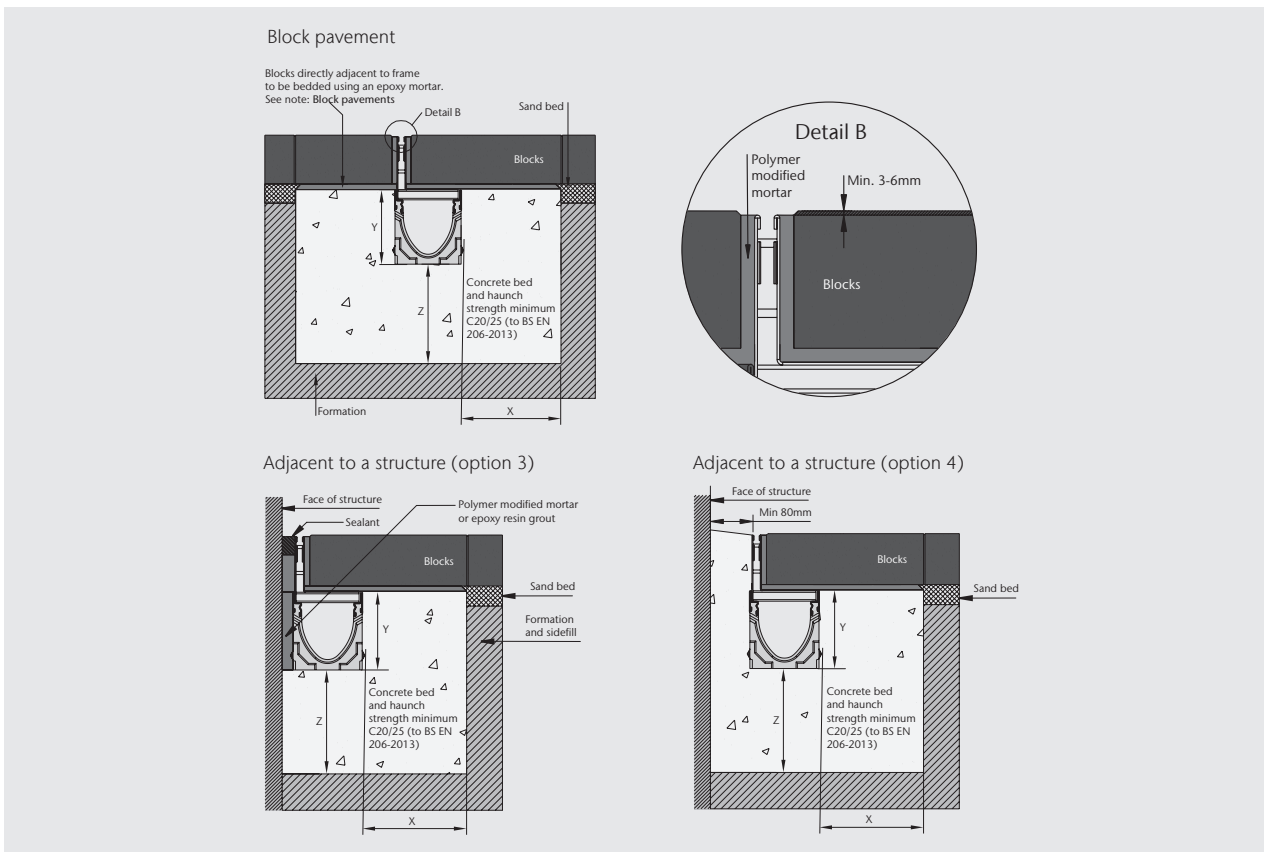

Channel protection

Avoid contact between compaction equipment and top of ACO channel edge rail. The installer must ensure that the finished surface level lies above the top of the edge rail (by at least 3-6mm). Covering or protecting the grating, before concreting the haunch or laying blocks, removes the time and cost associated with cleaning the channel and grating of cement material and embedded stones. (Please note that ACO channels must be installed with the grating in place to prevent deformation of the channel.)

Watertight installation to BS EN 1433:2002

Where ACO channel joints/fittings and channel/pavement interfaces are to be sealed, an appropriate sealant should be used (e.g. Sikaflex 11FC or similar). Guidance on the necessary surface preparation and/or priming should be sought from the sealant manufacturer. See page 65 for typical method of water tight sealing.

Best practice and workmanship

ACO can give guidance with respect to the most suitable methods of installation for each of the products in the ACO MultiDrain® MD range. ACO MultiDrain® MD should be installed using acceptable levels of workmanship and according to the National Code of Practice (UK: BS8000: Part 14: 1989) in keeping with EN 1433:2002 (Drainage channels for vehicular and pedestrian areas).

Detailed installation statements and methodologies will vary for all sites as each will have different aspects deserving particular consideration, consequently the relevant approvals should be sought from the consulting engineer and/or the installer.

Note: Galvanised iron and steel products have good corrosion resistance to concrete and mortar products but may experience corrosion if high chloride and sulphate content is present. Use only good quality concrete and consider using corrosion inhibitors where necessary. The use of protective coatings, such as paint, can minimise the risk of corrosion.

For further information please contact our Design Services Team (technical@aco.co.uk) or the ACO website www.aco.co.uk



Chemical resistance chart

Vienite®, ACO's sustainable high strength material, has a high resistance to dilute acids and alkalis, and is unaffected by road salt, fuel and oil, and other commonly encountered chemicals.

Further details of the chemical resistance can be obtained from the ACO Water Management Design Services team or, for particular chemicals, samples of the polymer concrete can be supplied to customers for their own testing. The chemical resistance will also depend on the temperature of the effluent. Clean water should not exceed 80°C.

The resistance of the gratings and edge rails should also be considered, and stainless steel gratings and edge rails are available in the ACO MultiDrain® MD system for aesthetically pleasing installations and for specific chemical resistance.

This chemical resistance chart refers to chemicals at ambient temperatures (20°C) and the results are for general guidance only.

Chemical medium	% conc	Resistance: Polyester concrete
Acetic acid, glacial	100	No
Acetic acid	10	Yes
Acetic anhydride	100	No
Acetone	10	No
Acetone	100	No
Alum	100	Yes
Aluminium sulphate	100	Yes
Ammonium chloride	100	Yes
Ammonium nitrate	100	Yes
Ammonium phosphate	65	Yes
Ammonium sulphate	100	Yes
Aniline (aminobenzene)	100	No
Barium chloride	100	Yes
Benzaldehyde	100	No
Benzene	100	No
Benzyl alcohol	100	Yes
Benzyl chloride	100	No
Borax	100	Yes
Boric acid	100	Yes
Bromine	100	No
Bromine water	Saturated	No
Butyl acetate	100	No
Butyric acid	100	Yes
Calcium carbonate	100	Yes
Calcium chloride	100	Yes
Calcium chlorate	8	Yes
Calcium hydroxide	100	Yes
Calcium nitrate	100	Yes
Carbon disulphide	100	No
Carbon tetrachloride	100	Yes
Castor oil	100	Yes
Chlorine gas, wet	100	No
Chlorine water	Saturated	No
Chlorobenzene	100	Yes
Chloroform		
(trichloro-methane)	100	No
Chromic acid	12	Yes
Citric acid	100	Yes
Copper chloride	100	Yes
Copper nitrate	100	Yes

Chemical medium	% conc	Resistance: Polyester concrete
Cyclohexane	100	Yes
Diesel fuel (DERV)	100	Yes
Dimethyl formamide	100	No
Dimethyl phthalate	100	Yes
Dioctyl phthalate	100	Yes
Ethanol	95	Yes
Ethanolamine	100	Yes
Ethyl acetate	100	No
Ethylene glycol	100	Yes
Ferrous chloride	100	Yes
Ferric chloride	100	Yes
Ferrous sulphate	100	Yes
Formaldehyde	30	Yes
Formic acid	10	Yes
Formic acid	100	No
Fuel oil	100	Yes
Gasoline	100	Yes
Glycerine	100	Yes
Hydrazine	50	No
Hydrobromic acid	48	Yes
Hydrochloric acid	10	Yes
Hydrofluoric acid	10	No
Hydrogen peroxide	30	Yes
Lactic acid	100	Yes
Lead acetate	100	Yes
Magnesium chloride	100	Yes
Magnesium sulphate	100	Yes
Maleic acid	100	Yes
Methyl ethyl ketone (MEK)	100	No
Motor oil	100	Yes
Nickel chloride	100	Yes
Nickel sulphate	100	Yes
Nitric acid	5	No
Nitrobenzine	100	No
Oleic acid	100	Yes
Oxalic acid	100	Yes
Perchloric acid	10	Yes
Perchloroethylene	100	Yes
Phosphoric acid	20	Yes
Phosphorus trichloride	100	No

Chemical medium	% conc	Resistance: Polyester concrete
Potassium carbonate	50	Yes
Potassium chloride	100	Yes
Potassium dichromate	100	Yes
Potassium hydroxide	10	Yes
Potassium nitrate	100	Yes
Potassium permanganate	10	No
Potassium sulphate	100	Yes
Pyridine	100	No
Sodium acetate	100	Yes
Sodium bromide	100	Yes
Sodium carbonate	35	Yes
Sodium chlorate	100	Yes
Sodium chloride	100	Yes
Sodium hydroxide		
(caustic soda)	50	No
Sodium hypochlorite	18	No
Sodium nitrate	100	Yes
Sodium nitrite	100	Yes
Sodium phosphate	10	Yes
Sodium sulphate	100	Yes
Sodium sulphide	100	Yes
Sodium sulphite	100	Yes
Sodium thiosulphate	100	Yes
Stearic acid	100	Yes
Styrene	100	No
Sulphuric acid	75	No
Sulphuric acid	50	Yes
Sulphuric acid at up to 40°C	10	Yes
Tetachloroethylene	100	Yes
Thioglycolic acid	80	Yes
Thionyl chloride	100	No
Toluene	100	Yes
Toluene sulphonic acid (aqueous solution)	Saturated	Yes
Trichloroacetic acid	50	Yes
Turpentine	100	Yes
Water	100	Yes
Xylene	100	Yes
Zinc sulphate	100	Yes

Specification clause

The surface drainage system shall be ACO MultiDrain® (Insert channel description as appropriate e.g. ACO M100D) channel system as supplied by ACO Technologies plc; all materials and components within the scope of this channel system shall be obtained from this manufacturer. The system shall be CE and UKCA marked and fully compliant with BS EN 1433:2002, certificated to Load Class (*) as defined in BS EN 1433:2002.

Declarations of Performance (DoP) shall be supplied to the Supervising Officer upon request. The system shall be of (100mm†, 150mm†, 200mm†) nominal internal width, manufactured in Vienite®, ACO's sustainable high strength material with cast-in (galvanised/stainless†) steel edge rails. The channels shall be installed with manufacturer's grating appropriate to the specified Load Class and locked securely in place using the manufacturer's Drainlock® boltless locking system.

The system shall be installed in accordance with the manufacturer's printed instructions, and the work carried out as specified in drawing no. (... ..) and in accordance with recognised good practice. Standards of workmanship shall generally be as specified in BS EN 752 and BS 8000:Part 14:1989.

† delete non-appropriate information.

* insert information C 250 or D 400 as appropriate.

Recycled content

ACO Technologies aim to incorporate as much recycled material or waste material as is practicable in their manufactured products. Typically, cast iron materials contain 40% to 90 % recycled iron, and steel products contain 25% to 33% recycled steel. The total recycled content of each product in the ACO MultiDrain® MD system will vary as the proportion of the different materials (in channels, edge rails, gratings etc) varies. As an example, ACO MultiDrain® MD channels with Heelguard™ ductile iron gratings will contain approximately 27% by weight recycled material.

General information

ACO products are subject to weight and dimensional tolerances. The weights and dimensions shown in this document are for guidance purposes only. ACO products are made from naturally occurring materials and may be subject to variations in colour, texture and marking. These aesthetic variations do not affect the performance or functionality of our Goods. The appearance of products shown in our company documentation are for illustration purposes only.

NBS specification

ACO MultiDrain® MD should be specified in section Q10:180. Assistance in completing this clause can be found in the ACO Water Management entry in NBS Source or please contact the ACO Water Management Design Services Team.

Note: A specification in NBS format is available to download from www.thenbs.com or www.aco.co.uk



The ACO MultiDrain® MD System is fully certified to BS EN 1433:2002 and CE and UKCA marked in accordance with the Construction Products Regulation.

Declarations of Performance are available via the DoP Data page on our website ([www.aco.co.uk/construction-products-regulation-\(cpr\)](http://www.aco.co.uk/construction-products-regulation-(cpr))), or on request. Please contact ACO Water Management Design Services Team on 01462 816666 for further information.

BS EN 1433:2002



ACO MultiDrain® channels with UltraSTEEL galvanised edge rails

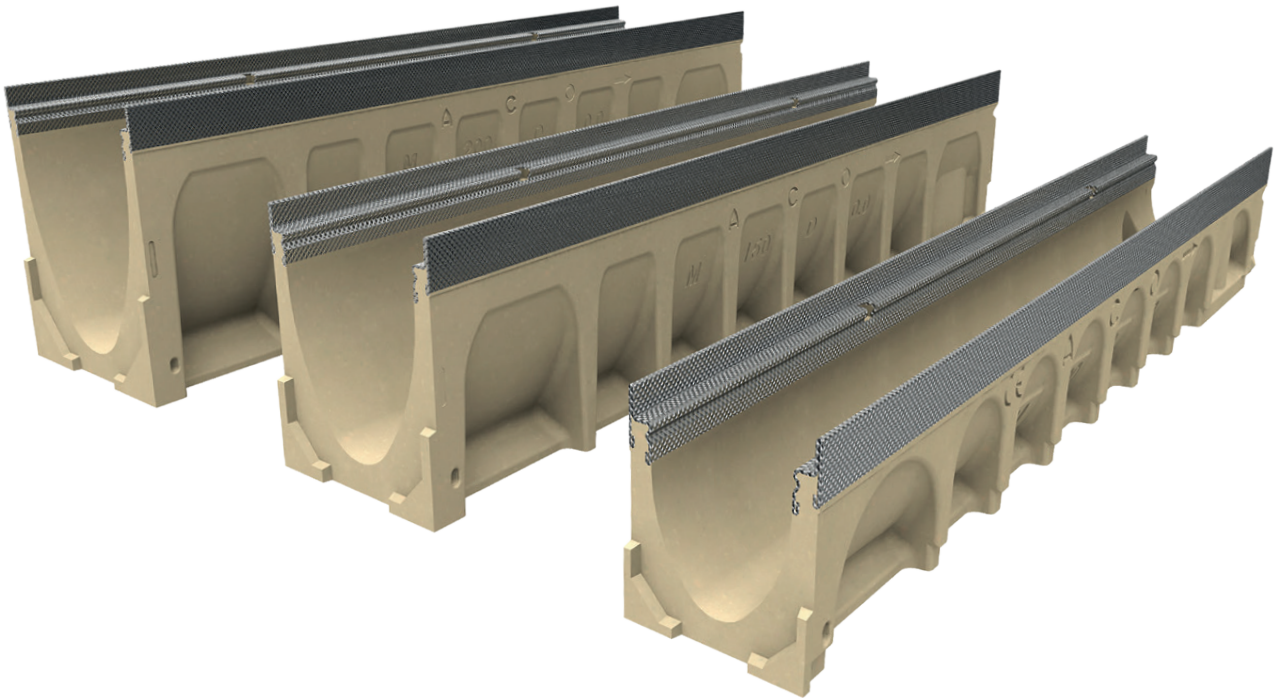

26

ACO MultiDrain® MD channels are manufactured from Vienite®, ACO's sustainable high strength material, which provides high chemical resistance. ACO MultiDrain® channels with integral galvanised steel protective edge rails are available in three widths M100D, M150D and M200D. Constant depth and shallow depth units are available in all three sized options. Whilst M100D channels are also available in sloping depth units.

For enhanced durability these rails are manufactured from UltraSTEEL™, a unique material that has improved strength over plain steel. The added benefit of UltraSTEEL™ is that its greater surface area improves the bond between rail and adjacent material where a sealed system is required.

For the ACO MultiDrain® M100D/M150D/M200D range of gratings to suit these channels please refer to pages 36 to 43.



ACO MultiDrain® MD channels

Product Code	Description	Length [mm]	Width Overall [mm]	Depth [mm]	Invert Depth [mm]	Invert Type	Weight [kg]
M100D Constant and sloping depth channels with UltraSTEEL™ galvanised edge rails							
23075	M100D No. 075	1000	135	75	55	1	9.2
23076	M100D No. 075V	1000	135	75*	55	1	8.9
23110	M100D No. 0100	1000	135	100	80	1	11.0
23111	M100D No. 0100V	1000	135	100*	80	1	10.7
23000	M100D No. 0.0*	1000	135	150	130	1/3	12.9
23050	M100D No. 0.1J*	500	135	150	130	1/3	7.6
23001	M100D No. 1	1000	135	150/155	130/135	2	13.5
23002	M100D No. 2	1000	135	155/160	135/140	2	13.8
23003	M100D No. 3	1000	135	160/165	140/145	2	14.1
23004	M100D No. 4	1000	135	165/170	145/150	2	14.4
23005	M100D No. 5	1000	135	170/175	150/155	2	14.7
23006	M100D No. 6	1000	135	175/180	155/160	2	15.0
23007	M100D No. 7	1000	135	180/185	160/165	2	15.3
23008	M100D No. 8	1000	135	185/190	165/170	2	15.6
23009	M100D No. 9	1000	135	190/195	170/175	2	15.9
23010	M100D No.10	1000	135	195/200	175/180	2	16.2
23100	M100D No.10.0*	1000	135	200	180	1/3	15.9
23101	M100D No.10.1J*	500	135	200	180	1/3	9.2
23011	M100D No.11	1000	135	200/205	180/185	2	16.5
23012	M100D No.12	1000	135	205/210	185/190	2	16.8
23013	M100D No.13	1000	135	210/215	190/195	2	17.1
23014	M100D No.14	1000	135	215/220	195/200	2	17.4
23015	M100D No.15	1000	135	220/225	200/205	2	17.7
23016	M100D No.16	1000	135	225/230	205/210	2	18.0
23017	M100D No.17	1000	135	230/235	210/215	2	18.3
23018	M100D No.18	1000	135	235/240	215/220	2	18.6
23019	M100D No.19	1000	135	240/245	220/225	2	18.9
23020	M100D No.20	1000	135	245/250	225/230	2	19.2
23200	M100D No.20.0*	1000	135	250	230	1/3	21.8
23201	M100D No.20.1J*	500	135	250	230	1/3	10.8
23300	M100D No.30.0*	1000	135	300	280	1/3	25.4
23301	M100D No.30.1J*	500	135	300	280	1/3	12.5

M100D 1m constant depth channel 0.0 to 30.0

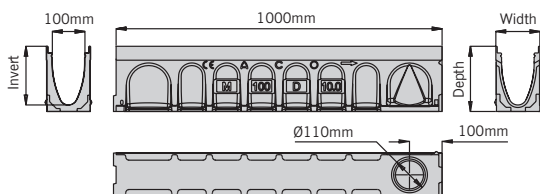

M100D 1m sloping depth channel

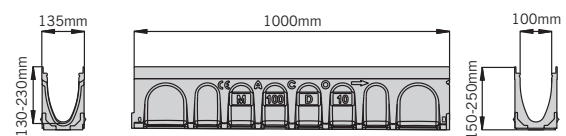

M100D 0.5m constant depth channel 0.1J to 30.1J

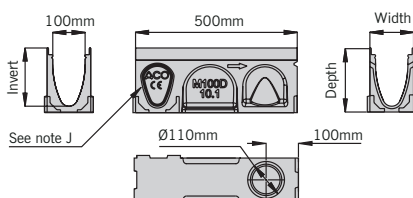

Note: The constant depth channels have an improved knockout feature, see page 41 for more information.

* Indicates channels supplied with a preformed Ø110mm knockout for vertical outlet.

J Indicates side knockout for 90° channel connection. Knockout on both sides of the channel.

ACO MultiDrain® MD channels

Product Code	Description	Length	Width Overall	Depth Overall	Invert Depth	Invert Type	Weight
		[mm]	[mm]	[mm]	[mm]		
M150D Constant depth channels with UltraSTEEL™ galvanised edge rails							
23156	M150D No. 0100	1000	185	100	75	1	15
23157	M150D No. 0100V	1000	185	100	75	1	14.9
23150	M150D No. 0.0*	1000	185	210	185	1/3	23.4
23153	M150D No. 0.1]†	500	185	210	185	1/3	12.7
23151	M150D No.10.0*	1000	185	260	235	1/3	26.2
23154	M150D No. 10.1]†	500	185	260	235	1/3	14.6
23152	M150D No.20.0*	1000	185	310	285	1/3	30.3
23155	M150D No. 20.1]†	500	185	310	285	1/3	16.4

M150D 1m constant depth channel 0.0 to 20.0

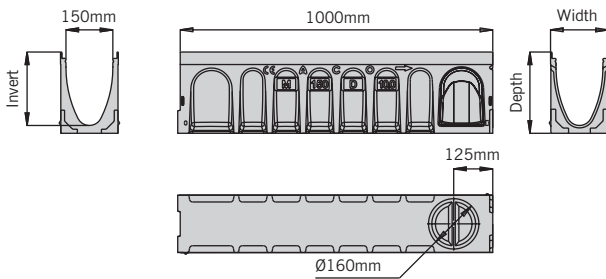

M150D 0.5m constant depth channel 0.1] to 20.1]

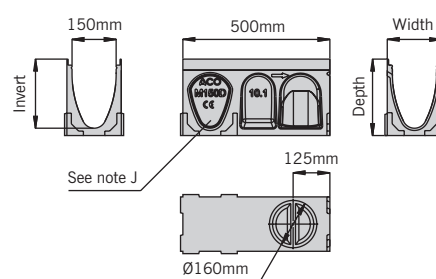

M200D Constant depth channels with UltraSTEEL™ galvanised edge rails

23216	M200D No. 0100	1000	235	100	75	1	17.5
23217	M200D No. 0100V	1000	235	100	75	1	17.0
23210	M200D No. 0.0*	1000	235	265	240	1/3	33
23213	M200D No. 0.1]†	500	235	265	240	1/3	17.9
23211	M200D No.10.0*	1000	235	315	290	1/3	37.4
23214	M200D No. 10.1]†	500	235	315	290	1/3	19.9
23212	M200D No.20.0*	1000	235	365	340	1/3	40.4
23215	M200D No. 20.1]†	500	235	365	340	1/3	21.9

M200D 1m constant depth channel 0.0 to 20.0

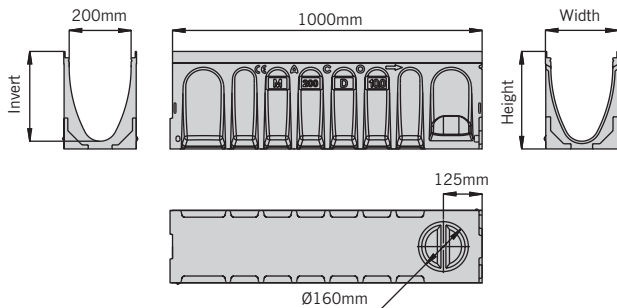

M200D 0.5m constant depth channel 0.1] to 20.1]

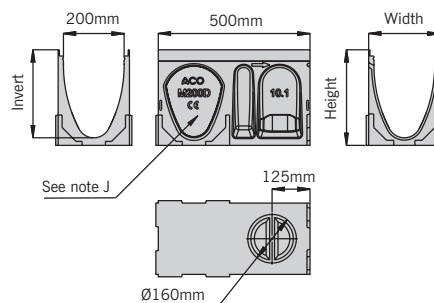

Note: The constant depth channels have an improved knock-out feature, see page 41 for more information.

* Indicates channels supplied with a preformed Ø110mm knock-out for vertical outlet.

] Indicates side knock-out for 90° channel connection. Knock-out on both sides of the channel.

V Indicates channel with cast in TPE triple lipped seals for water tight connection. See page 41 for further information.

† 075V and 0100V channels have a depth overall around the outlet of 80mm (075V) and 105 (0100V).

These products are subject to weight and dimensional tolerances. The dimensions shown on this page are for guidance purposes only.

ACO MultiDrain® MD components

Product Code	Description	Length [mm]	Width Overall [mm]	Depth Overall [mm]	Invert Depth [mm]	Invert Type	Weight [kg]
Multifunctional endcap (closing/inlet/outlet)							
23404	M100D multifunctional endcap	-	135	75/300	50	-	0.2
23159	M150D multifunctional endcap	-	185	310/100	75	0.3	
23219	M200D multifunctional endcap	-	235	365/100	75	-	0.4

The multifunctional endcap can be cut down to suit all channels. See page 65 for further information.

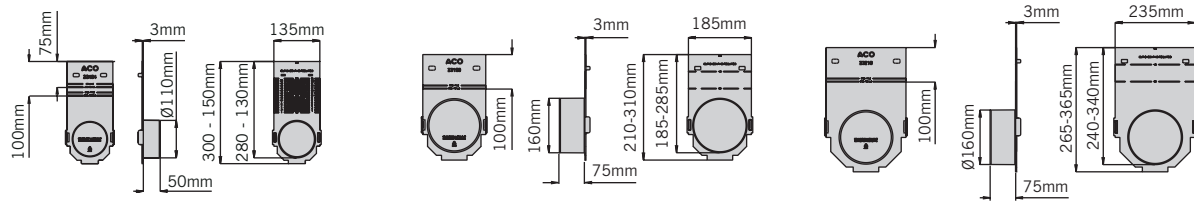

Step connector

12601	M100D 50mm Step connector	100	75	50	-	-	0.4
13001	M150D 50mm Step connector	100	98	50	-	-	0.5
13401	M200D 50mm Step connector	100	120	50	-	-	0.6

Note: For information on the Step connector functionality see page 64.

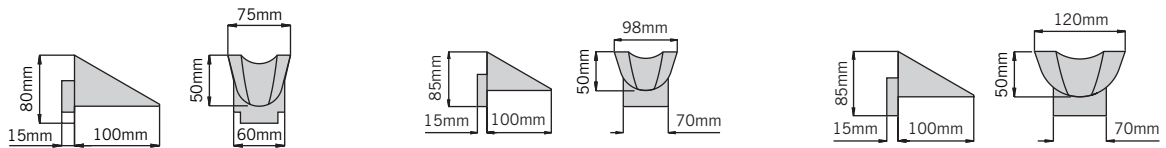

ACO MultiDrain® MD components

Product Code	Description	Length	Width Overall	Depth Overall	Invert Depth	Invert Type	Weight
		[mm]	[mm]	[mm]	[mm]		
Universal gully and components							
33401	Gully assembly and bucket 601D	440	440	1315	870	-	52.5
33402	Gully assembly no bucket 602D	440	440	1315	870	-	51
33407	Gully top assembly 607D	440	440	655	-	-	45
33605	Gully base unit 605	-	Ø375	750	310	-	4.3
33603	Gully intermediate unit 603	440	440	515	-	-	5.1
44355	Gully grating and frame 600D	400*	564††	100	-	-	40
7060	Gully connector 615	500	Ø500	40	-	-	7
33606	Bucket polyethylene 606	-	Ø275	245	-	-	1.4

Product code: 33401 and 33402

Product code: 33407

Product code: 7060

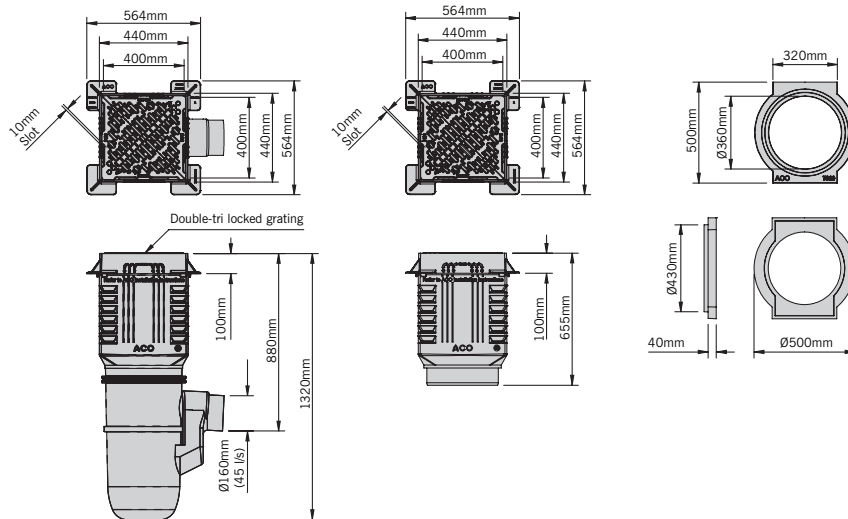

Note. Plain U-PVC 150mm - 160mm Supersleeve adaptor supplied with 601D, 602D and 605 assemblies.
 For information on Universal gully functionality see page 43. *Clear opening size. ††Over frame size.
 These products are subject to weight and dimensional tolerances. The dimensions shown on this page are for guidance purposes only.

Product Code	Description	Length [mm]	Width Overall [mm]	Depth Overall [mm]	Invert Depth [mm]	Invert Type	Weight [kg]
--------------	-------------	----------------	-----------------------	-----------------------	----------------------	-------------	----------------

M100D Universal sump unit with UltraSTEEL™ galvanised edge rails

23410	M100D Universal sump with plastic silt bucket	500	135	635	615	-	32.8
-------	---	-----	-----	-----	-----	---	------

Note: Drawing shows flow through un-trapped unions. For information on the sump unit functionality see page 66.

Standard sump outlets

- 1 = Ø110mm outlet with triple lipped seal
- 2 = Ø110mm knockout
- 3 = Ø160mm knockout

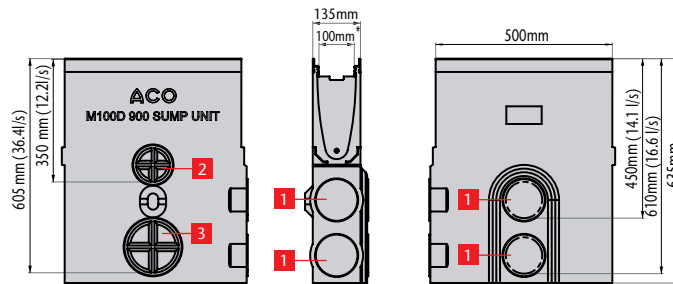

M150D Universal sump unit with UltraSTEEL™ galvanised edge rails

23158	M150D Universal sump with plastic silt bucket	500	185	735	715	-	43.4
-------	---	-----	-----	-----	-----	---	------

Note: Drawing shows flow through un-trapped unions. For information on the sump unit functionality see page 66.

Standard sump outlets

- 1 = Ø110mm outlet with triple lipped seal
- 2 = Ø160mm knockout
- 3 = Ø200mm knockout

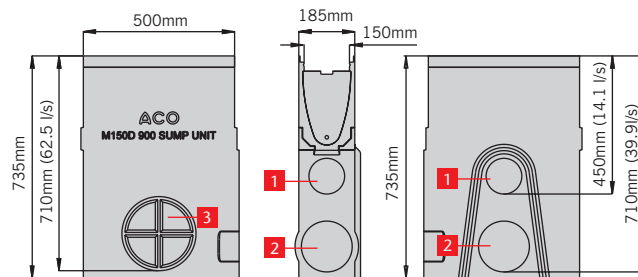

M200D Universal sump unit with UltraSTEEL™ galvanised edge rails

23218	M200D Universal sump with plastic silt bucket	500	235	790	765	-	47
-------	---	-----	-----	-----	-----	---	----

Note: Drawing shows flow through un-trapped unions. For information on the sump unit functionality see page 66.

Standard sump outlets

- 1 = Ø110mm outlet with triple lipped seal
- 2 = Ø160mm knockout
- 3 = Ø200mm knockout

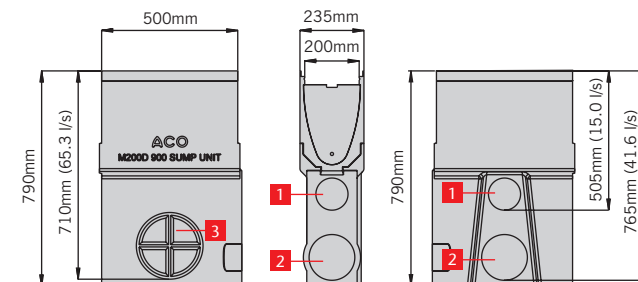

Product Code	Description	Length	Width Overall	Depth Overall	Invert Depth	Invert Type	Weight [kg]
		[mm]	[mm]	[mm]	[mm]		
M100D Drain unions and foul air traps							
0056	820 Drain union PVC-U Ø110mm (max 16.6 l/s)	100	110	-	605	-	0.1
0058	822 Drain union PVC-U Ø160mm (max 36.4 l/s)	100	160	-	605	-	0.5
2640	920 Foul air trap PVC-U Ø110mm (max 12.2 l/s)	-	110	-	360	-	0.5
2638	922 Foul air trap PVC-U Ø160mm (max 25 l/s)	-	160	-	340	-	1.9
7931	940 Roddable foul air trap MDPE Ø110mm (max 14 l/s)	-	110	-	450	-	0.4
7932	950 Roddable foul air trap MDPE Ø160mm (max 29 l/s)	-	160	-	400	-	0.8

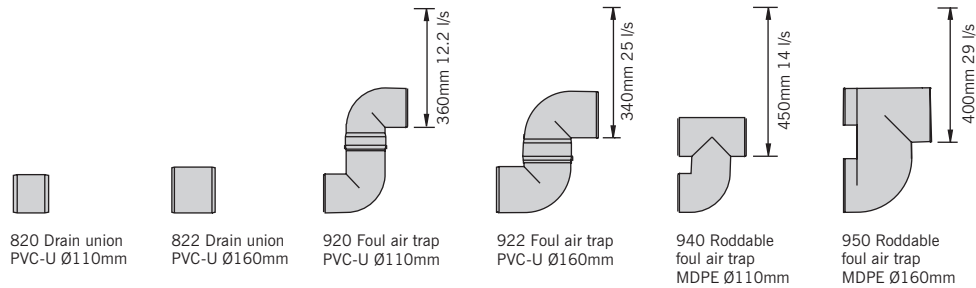

M150D Drain unions and foul air traps							
0056	820 Drain union PVC-U Ø110mm (max 14.1 l/s)	100	110	-	450	-	0.1
0058	822 Drain union PVC-U Ø160mm (max 39.9 l/s)	100	160	-	710	-	0.5
2723	823 Drain Union PVC-U Ø200mm (max 69.5 l/s)	200	200	-	710	-	0.6
2638	922 Foul air trap PVC-U Ø160mm (max 31 l/s)	-	160	-	445	-	1.9
7932	950 Roddable foul air trap MDPE Ø160mm (max 32 l/s)	-	160	-	505	-	0.8

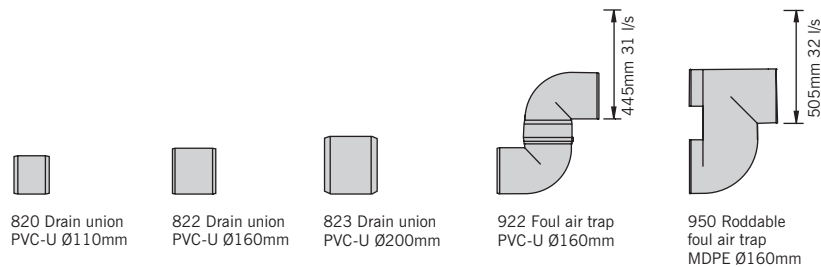

Product Code	Description	Length	Width Overall	Depth Overall	Invert Depth	Invert Type	Weight
		[mm]	[mm]	[mm]	[mm]		
M200D Drain unions and foul air traps							
0056	820 Drain union PVC-U Ø110mm (max 15.0 l/s)	100	110	-	505	-	0.1
0058	822 Drain union PVC-U Ø160mm (max 41.6 l/s)	100	160	-	765	-	0.5
2723	823 Drain Union PVC-U Ø200mm (max 72 l/s)	200	200	-	765	-	0.6
2638	922 Foul air trap PVC-U Ø160mm (max 32 l/s)	-	160	-	500	-	1.9
7932	950 Roddable foul air trap MDPE Ø160mm (max 34 l/s)	-	160	-	560	-	0.8

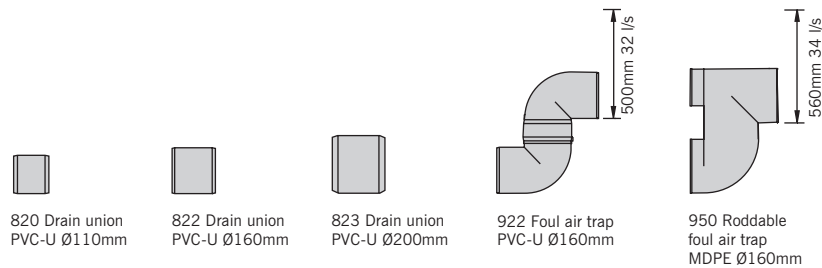

Polymer concrete repair kit

ACO's Polymer concrete repair kit is available for bonding applications, for instance where a mitred channel joint is to be made or for the repair of small areas of aesthetic damage. For further product details please see page 67.



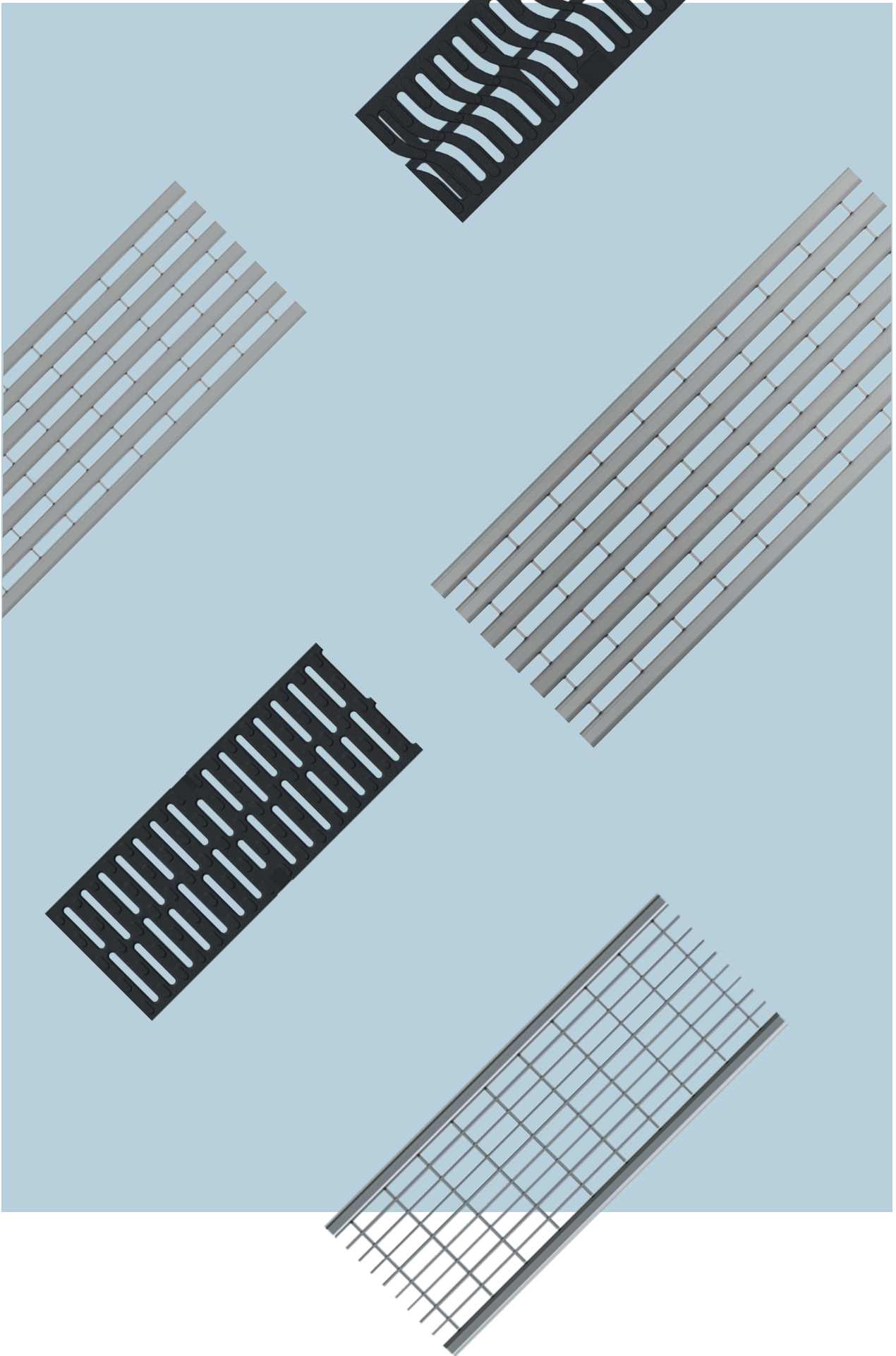

Gratings for use with ACO MultiDrain® channels with UltraSTEEL™ galvanised edge rails

ACO MultiDrain® gratings range provides designers with a wide choice of styles to complete their surface water drainage system.

Grates which are compatible with galvanised edged channels include ductile iron, galvanised steel and composite materials. They incorporate our unique ACO Drainlock™ fixings which improves hydraulic capacity of the channel.

The wide range of grating styles includes traditional Slotted, modern Mesh and Profile, and heritage designs like Mosaic. The newly introduced Intercept D 400 grate, which encompasses the principles of minimalist design, giving superior water interception capabilities, and whilst it is functional it also achieves the goal of wide visual appeal.

ACO MultiDrain® channels are also compatible with our Freestyle range of grates, a select range of designs for unique projects. There is an extensive range of pre-moulded designs, and if a bespoke design is required our team can make your design a reality in our foundry in Germany.

ACO Brickslot ST is a subtle and unobtrusive grating, which when combined with an ACO MultiDrain® MD channel, can be used as a solution to complement discreet drainage applications and is ideal for use against buildings facades. Designed with a heelguard 10mm single offset drainage inlet, or a double Twinslot inlet in either offset or central.

Compatible with most paving materials, the vertical sides of the grating enable pavements to be laid directly to the unit's edge. Once installed the system is totally secure and not vulnerable to vandalism or loose grates making it a suitable for applications such as schools and playgrounds where grating removal can become a hazard.

The channel and ACO Brickslot ST grating together provide an unobtrusive continuous slot drainage system, with high hydraulic efficiency for fast removal of surface water. The system includes an ACO Brickslot ST access unit to ensure easy maintenance and access to the drainage system.



ACO Bespoke Brickslot is custom designed to suit specific customer requirements for MultiDrain 100, 150 and 200 channels. To accommodate specific sites, ACO Brickslot grates can be manufactured in different heights (30mm to 200mm) and also custom slot widths and lengths (up to 1m). The Brickslot can be manufactured from mild steel with a hot dipped galvanised finish or stainless steel for increased corrosion resistance. Please contact your sales representative to discuss.

ACO MultiDrain® gratings are suitable for applications up to and including Load Class D 400 (This product is not suitable for carriageways of public roads or motorways).

Gratings for use with ACO MultiDrain® M100D channels with UltraSTEEL™ galvanised edge rails

Product Code	Description	Length [mm]	Width Overall [mm]	Depth Overall [mm]	Slot width/ hole dia [mm]	Heelguard™	Intake area (mm ² /m)	Anti shunt feature	Weight [kg]
Gratings for Load Class A 15 applications									
12610	Slotted galvanised steel grate	1000	123	21	10	Yes	25300	n/a	2.0
12611	Slotted galvanised steel grate	500	123	21	10	Yes	25300	n/a	1.0
12666	Perforated galvanised steel grate	1000	123	21	6	Yes	16300	n/a	2.6
12667	Perforated galvanised steel grate	500	123	21	6	Yes	16300	n/a	1.3

12610 / 12611



12666 / 12667

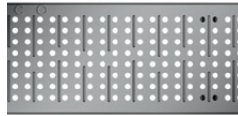

Gratings for Load Class B 125 applications									
132555	Intercept Profile galvanised steel grate B	1000	123	21	8	Yes	44500	Yes	4.1
132550	Intercept Profile galvanised steel grate B	500	123	21	8	Yes	44500	Yes	2.0

132555 / 132550



Product Code	Description	Length [mm]	Width Overall [mm]	Depth Overall [mm]	Slot width/ hole dia [mm]	Heelguard™	Intake area (mm ² /m)	Anti shunt feature	Weight [kg]
--------------	-------------	-------------	--------------------	--------------------	---------------------------	------------	----------------------------------	--------------------	-------------

Gratings for Load Class C 250 applications

132720	Heelguard™ composite black grate	500	123	21	8	Yes	28500	Yes	1.0
12614	Slotted galvanised steel grate	1000	123	21	10	Yes	25300	n/a	5.0
12615	Slotted galvanised steel grate	500	123	21	10	Yes	25300	n/a	2.5
12656	Perforated galvanised steel grate	1000	123	21	6	Yes	16300	n/a	4.8
12657	Perforated galvanised steel grate	500	123	21	6	Yes	16300	n/a	2.4
132880	Heelguard™ mesh galvanised steel grate δ	1000	123	21	9.5	Yes	80000	Yes	4.2
132881	Heelguard™ mesh galvanised steel grate δ	500	123	21	9.5	Yes	80000	Yes	2.1
445598	Brickslot ST galvanised steel grate	1000	123	105	10	Yes	10000	n/a	5.1
445599	Brickslot ST galvanised steel grate	500	123	105	10	Yes	10000	n/a	2.6
445603	Brickslot ST access unit galvanised steel grate	500	123	105	10	Yes	10000	n/a	5.4

132720

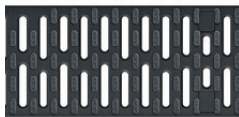

12614 / 12615



12656 / 12657

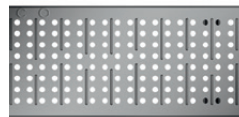

132880 / 132881



445598 / 445599

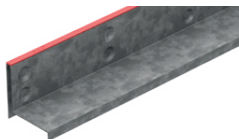

445603

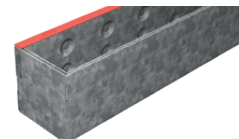

δ Indicates security locking available.

Gratings for use with ACO MultiDrain® M100D channels with UltraSTEEL™ galvanised edge rails

Product Code	Description	Length [mm]	Width Overall [mm]	Depth Overall [mm]	Slot width/ hole dia [mm]	Heelguard™	Intake area (mm ² /m)	Anti shunt feature	Weight [kg]
Gratings for Load Class D 400* applications									
23405	Heelguard™ ductile iron grate 6	500	123	21	8	Yes	23900	Yes	4.1
23510	Heelguard™ Intercept ductile iron grate	500	123	21	10	Yes	41400	Yes	3.7
23406	Ductile iron solid cover grate	500	123	21	n/a	No	n/a	Yes	4.5
23408	Slotted ductile iron grate	500	123	21	12	No	35700	Yes	3.8
132042	Flag ductile iron grate	500	123	21	8	Yes	30400	Yes	4.9
132043	Leaf ductile iron grate	500	123	21	10	Yes	34700	Yes	4.7
132885	Heelguard™ mesh galvanised steel grate 6	1000	123	21	8.5	Yes	69100	Yes	5.1
132886	Heelguard™ mesh galvanised steel grate 6	500	123	21	8.5	Yes	69100	Yes	2.5
446015	Brickslot ST galvanised steel grate	1000	123	105	10	Yes	10000	n/a	7.1
446016	Brickslot ST galvanised steel grate	500	123	105	10	Yes	10000	n/a	3.7
446017	Brickslot ST access unit galvanised steel grate	500	123	105	10	Yes	10000	n/a	7.2
23480	Brickslot Twinslot offset galvanised steel	1000	123	105	10	Yes	20000	n/a	12.9
23481	Brickslot Twinslot offset galvanised steel	500	123	105	10	Yes	20000	n/a	6.1
23482	Brickslot Twinslot offset access unit galvanised steel	500	123	105	10	Yes	20000	n/a	8.1
23483	Brickslot Twinslot central galvanised steel	1000	123	105	10	Yes	20000	n/a	12.5
23484	Brickslot Twinslot central galvanised steel	500	123	105	10	Yes	20000	n/a	7
23485	Brickslot Twinslot central access unit galvanised steel	500	123	105	10	Yes	20000	n/a	8.2

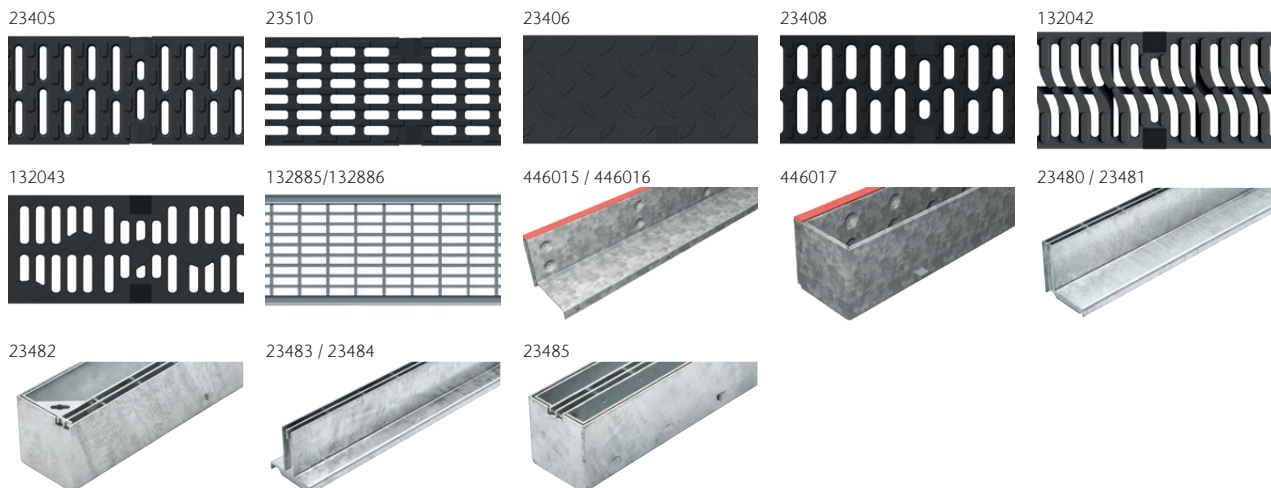

ACO ATec high performance finish

Product Code	Description	Length [mm]	Width Overall [mm]	Depth Overall [mm]	Slot width/ hole dia [mm]	Intake area (mm ² /m)	Anti shunt feature	Weight [kg]
--------------	-------------	-------------	--------------------	--------------------	---------------------------	----------------------------------	--------------------	-------------

Gratings for Load Class D 400* applications with ACO ATec corrosion resistant coating

23409	ATec coated Heelguard™ ductile iron grate Ⓓ	500	123	21	8	23900	Yes	4.1
23417	ATec coated Mosaic ductile iron grate Ⓓ	500	123	21	10	28000	Yes	4.1



ACO ATec coating is a high performance finish that provides a superior resistance to corrosion. The electrochemically applied finish is strong and durable, making maintenance easier than on water-based surface coatings. The ATec finish also enhances long term durability in demanding environments and is particularly well suited for low trafficked areas. Please download our maintenance brochure and ATec datasheet for more information.

Product Code	Description	For use with	Length [mm]	Width Overall [mm]	Depth Overall [mm]	Weight [kg]
--------------	-------------	--------------	-------------	--------------------	--------------------	-------------

Grating accessories

23415	Drainlock™ security locking assembly	132720, 23405, 23409, 23417	96	20	13	0.1
445828	Drainlock™ security locking assembly Mesh C250**	132880, 132881	96	27	13	0.1
445745	Drainlock™ security locking assembly Mesh D400**	132885, 132886	96	27	13	0.1
445830	Drainlock™ security locking assembly Profile**	132555, 132550	96	27	13	0.1
23416	Drainlock™ security key	23415	75	30	3	0.01
1367	Drainlock™ grating lifting tool	all	400	150	6	0.2

23415 Drainlock™ security locking assembly

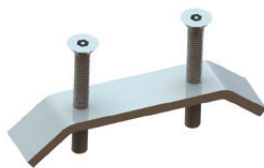

445828 Drainlock™ security locking assembly Mesh C250**

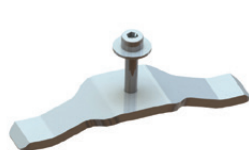

445745 Drainlock™ security locking assembly Mesh D400**

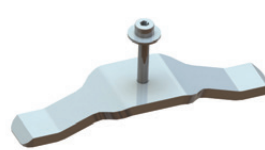

445830 Drainlock™ security locking assembly Profile**

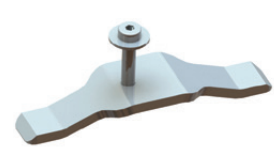

23416 Drainlock security key



1367 Drainlock™ grating lifting tool



Ⓓ Indicates security locking available.

* Not suitable for carriageways of public roads or motorways

** Security key 23416 not compatible, Allen key required

Note: 1m grates require 2pcs of Security locking assemblies and 0.5m grates require 1pc

Gratings for use with ACO MultiDrain® M150D channels with UltraSTEEL™ galvanised edge rail

Product Code	Description	Length [mm]	Width Overall [mm]	Depth Overall [mm]	Slot width/ hole dia [mm]	Heelguard™	Intake area (mm ² /m)	Anti shunt feature	Weight [kg]
Gratings for Load Class B 125 applications									
133601	Heelguard™ mesh galvanised steel grate 6	1000	173	36	10	Yes	118200	Yes	5.4
133602	Heelguard™ mesh galvanised steel grate 6	500	173	36	10	Yes	118200	Yes	2.7
133625	Intercept-Profile galvanised steel grate 6	1000	173	30	9	Yes	68700	Yes	5
133626	Intercept-Profile galvanised steel grate 6	500	173	30	9	Yes	68700	Yes	2.5

133601 / 133602



133625 / 133626



Gratings for Load Class C 250 applications

133605	Heelguard™ mesh galvanised steel grate 6	1000	173	40	10	Yes	118200	Yes	5.8
133606	Heelguard™ mesh galvanised steel grate 6	500	173	40	10	Yes	118200	Yes	2.8

133605 / 133606



ACO ATec high performance finish

Gratings for Load Class D 400* applications with ACO ATec corrosion resistant coating

23169	ATec coated Heelguard ductile iron grate 6	500	173	28	8	Yes	40000	Yes	6.8
-------	---	-----	-----	----	---	-----	-------	-----	-----

23169



6 Indicates security locking available.

◆ ACO ATec coating is a high performance finish that provides a superior resistance to corrosion. The electrochemically applied finish is strong and durable, making maintenance easier than on water-based surface coatings. The ATec finish also enhances long term durability in demanding environments and is particularly well suited for low trafficked areas. Please download our ATec datasheet for more information.

Product Code	Description	Length [mm]	Width Overall [mm]	Depth Overall [mm]	Slot width/ hole dia [mm]	Heelguard™	Intake area (mm ² /m)	Anti shunt feature	Weight [kg]
Traditional gratings for Load Class D 400* applications									
23161	Heelguard™ ductile iron grate Ⓓ	500	173	28	8	Yes	40000	Yes	6.8
23515	Heelguard™ Intercept ductile iron grate	500	173	36	10	Yes	55500	Yes	6.4
23160	Solid cover ductile iron grate	500	173	28	n/a	No	n/a	Yes	6.7
23164	Slotted ductile iron grate	500	173	28	12	No	57664	Yes	6.4
133609	Heelguard™ mesh galvanised steel grate Ⓓ	1000	173	46	10	Yes	103400	Yes	8
133610	Heelguard™ mesh galvanised steel grate Ⓓ	500	173	46	10	Yes	103400	Yes	4
446027	Brickslot ST galvanised steel grate	1000	173	105	10	Yes	10000	n/a	8.7
446028	Brickslot ST galvanised steel grate	500	173	105	10	Yes	10000	n/a	4.5
446029	Brickslot ST access unit galvanised steel grate	500	173	105	10	Yes	10000	n/a	9.1

23161

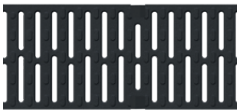

23515

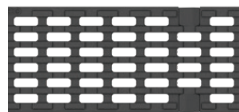

23160

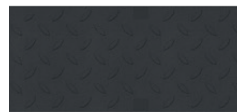

23164



133609 / 133610



446027 / 446028

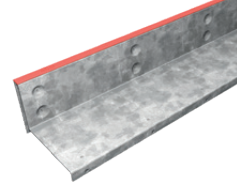

446029

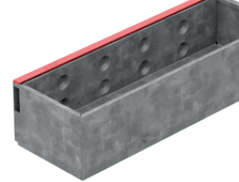

Product Code	Description	For use with	Length [mm]	Width Overall [mm]	Depth Overall [mm]	Weight [kg]
Grating accessories						
23165	Drainlock™ security locking assembly	23161, 23169	146	20	13	0.1
445831	Drainlock™ security locking assembly Mesh**	133601, 133602, 133605, 133606, 133609, 133610	146	27	13	0.1
445833	Drainlock™ security locking assembly Profile**	133625, 133626	146	27	13	0.1
23416	Drainlock™ security key	23165	75	30	3	0.01
1367	Drainlock™ grating lifting tool	all	400	150	6	0.2

Ⓓ Indicates security locking available.

* Not suitable for carriageways of public roads or motorways

** Security key 23416 not compatible, allen key required

Note: 1m grates require 2pcs of Security locking assemblies and 0.5m grates require 1pc

Gratings for use with ACO MultiDrain® M200D channels with galvanised edge rails

Product Code	Description	Length [mm]	Width Overall [mm]	Depth Overall [mm]	Slot width/ hole dia [mm]	Heelguard™	Intake area (mm ² /m)	Anti shunt feature	Weight [kg]
--------------	-------------	-------------	--------------------	--------------------	---------------------------	------------	----------------------------------	--------------------	-------------

Gratings for Load Class B 125 applications

133613	Heelguard™ mesh galvanised steel grate 6	1000	223	40	10	Yes	157500	Yes	7.2
133614	Heelguard™ mesh galvanised steel grate 6	500	223	40	10	Yes	157500	Yes	3.6
133629	Intercept-Profile galvanised steel grate 6	1000	223	39	8	Yes	84600	Yes	7.4
133630	Intercept-Profile galvanised steel grate 6	500	223	39	8	Yes	84600	Yes	3.6

133613 / 133614

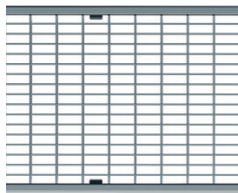

133629 / 133630



Gratings for Load Class C 250 applications

133617	Heelguard™ mesh galvanised steel grate 6	1000	223	46	10	Yes	137700	Yes	10.7
133618	Heelguard™ mesh galvanised steel grate 6	500	223	46	10	Yes	137700	Yes	5.2

133617 / 133618

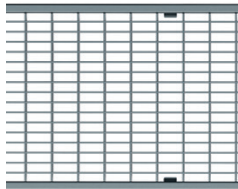

ACO ATec high performance finish

Gratings for Load Class D 400* applications with ACO ATec corrosion resistant coating

23229	ATec coated Heelguard ductile iron grate 6	500	223	32	8	Yes	47300	Yes	10.3
-------	---	-----	-----	----	---	-----	-------	-----	------

23229

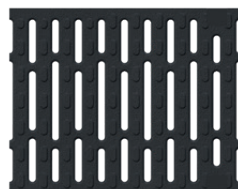

6 Indicates security locking available.

◆ ACO ATec coating is a high performance finish that provides a superior resistance to corrosion. The electrochemically applied finish is strong and durable, making maintenance easier than on water-based surface coatings. The ATec finish also enhances long term durability in demanding environments and is particularly well suited for low trafficked areas. Please download our ATec datasheet for more information.

Product Code	Description	Length [mm]	Width Overall [mm]	Depth Overall [mm]	Slot width/ hole dia [mm]	Heelguard™	Intake area (mm ² /m)	Anti shunt feature	Weight [kg]
--------------	-------------	-------------	--------------------	--------------------	---------------------------	------------	----------------------------------	--------------------	-------------

Gratings for Load Class D 400* applications

23221	Heelguard™ ductile iron grate Ⓢ	500	223	32	8	Yes	47300	Yes	7.5
23520	Heelguard™ Intercept ductile iron grate	500	223	43	10	Yes	76800	Yes	8.7
23220	Ductile iron solid cover grate	500	223	32	n/a	No	n/a	Yes	11
23224	Slotted ductile iron grating	500	223	32	12	No	72400	Yes	9.8
133621	Heelguard™ mesh galvanised steel grate Ⓢ	1000	223	65	10	Yes	137700	Yes	12.9
133622	Heelguard™ mesh galvanised steel grate Ⓢ	500	223	65	10	Yes	137700	Yes	6.4
446039	Brickslot ST galvanised steel grate	1000	223	105	10	Yes	10000	n/a	8.1
446040	Brickslot ST galvanised steel grate	500	223	105	10	Yes	10000	n/a	4.2
446041	Brickslot ST access unit galvanised steel grate	500	223	105	10	Yes	10000	n/a	10.3

23221

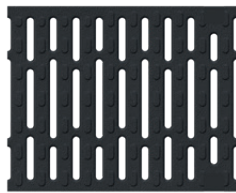

23520

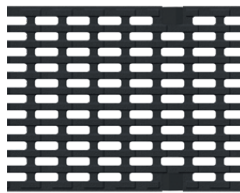

23220

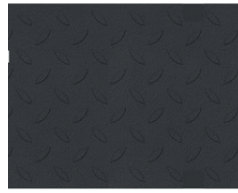

23224

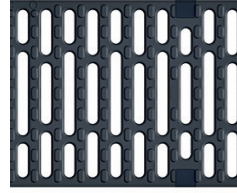

133621

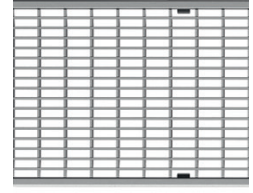

446039 / 446040

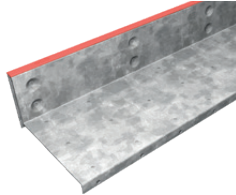

446041

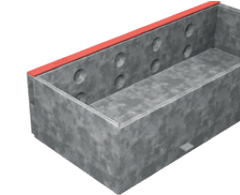

Product Code	Description	For use with	Length [mm]	Width Overall [mm]	Depth Overall [mm]	Weight [kg]
--------------	-------------	--------------	-------------	--------------------	--------------------	-------------

Grating accessories

23225	Drainlock™ security locking assembly	23221, 23229	195	20	13	0.1
445834	Drainlock™ security locking assembly Mesh**	133613, 133614, 133617, 133618, 133621, 133622	195	27	13	0.1
445836	Drainlock™ security locking assembly Profile**	133629, 133630	195	27	13	0.1
23416	Drainlock™ security key	23225	75	30	3	0.01
1367	Drainlock™ grating lifting tool	all	400	150	6	0.2

Ⓢ Indicates security locking available.

* Not suitable for carriageways of public roads or motorways

** Security key 23416 not compatible, allen key required

Note: 1m grates require 2pcs of Security locking assemblies and 0.5m grates require 1pc

ACO MultiDrain® channels with stainless steel edge rails

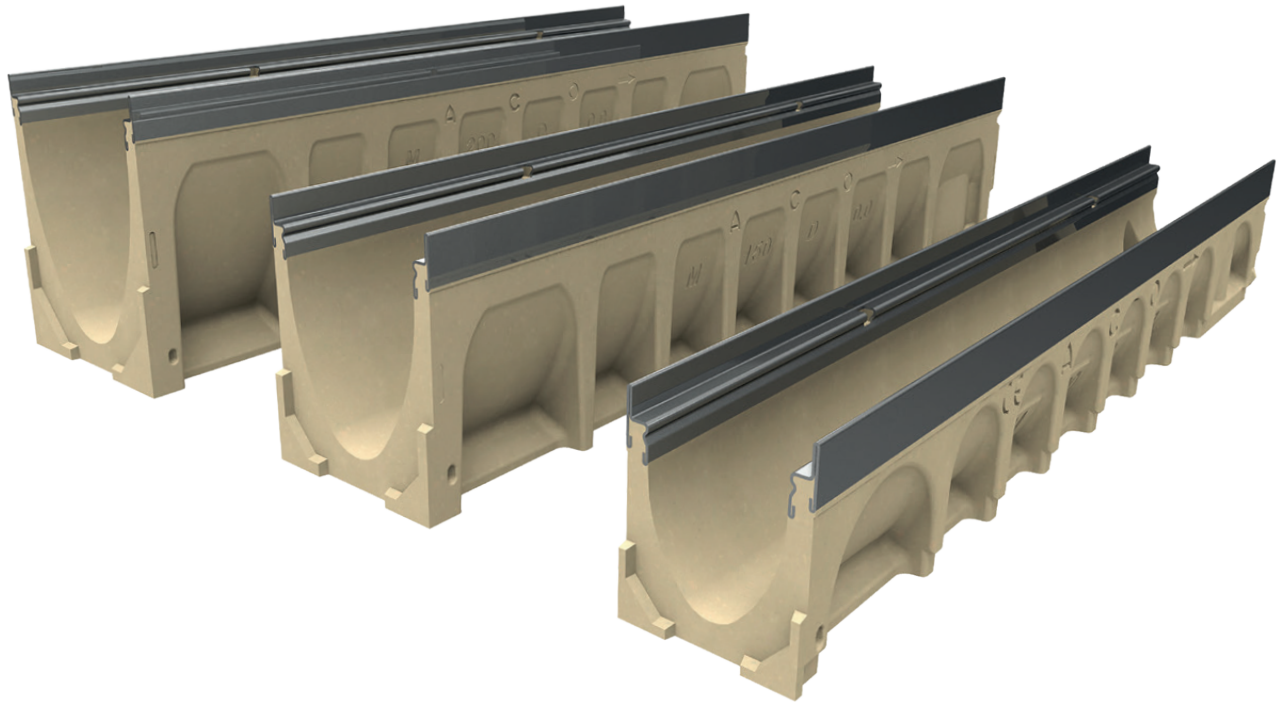

44

ACO MultiDrain® MD channels are manufactured from Vienite®, ACO's sustainable high strength material, which provides high chemical resistance.

ACO MultiDrain® channels with integral stainless steel protective edge rails are available in three widths M100DS, M150DS and M200DS. Constant depth and shallow depth units are available in all three sized options.

For improved aesthetics and performance, the channels listed below are provided with integral stainless steel (Grade 304) protective edge rails.

For the ACO MultiDrain® M100DS/M150DS/M200DS range of gratings to suit these channels please refer to pages 51 to 58.



ACO MultiDrain® MD channels

Product Code	Description	Length [mm]	Width Overall [mm]	Depth Overall [mm]	Invert Depth [mm]	Invert Type	Weight [kg]
M100DS constant depth channels with stainless steel edge rails							
24075	M100DS No. 075	1000	135	75	55	1	10.9
24076	M100DS No. 075V	1000	135	75†	55	1	10.6
24110	M100DS No. 0100	1000	135	100	80	1	12.7
24111	M100DS No. 0100V	1000	135	100†	80	1	12.4
24000	M100DS No. 0.0*	1000	135	150	130	1/3	14.9
24050	M100DS No. 0.1j*	500	135	150	130	1/3	8.6
24100	M100DS No.10.0*	1000	135	200	180	1/3	17.9
24101	M100DS No.10.1j*	500	135	200	180	1/3	10.2
24200	M100DS No.20.0*	1000	135	250	230	1/3	21
24201	M100DS No.20.1j*	500	135	250	230	1/3	11.8

M100DS 075 – 0100 channel

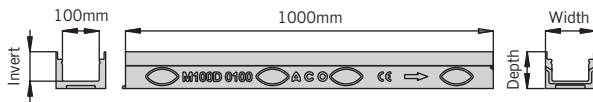

M100DS 075V – 100V channel

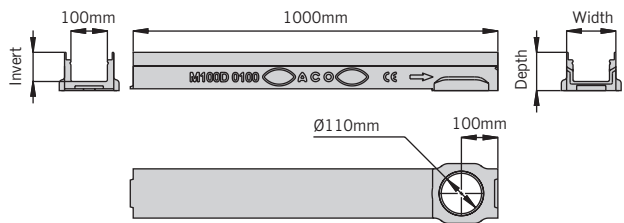

M100DS 1m constant depth channel 0.0 to 20.0

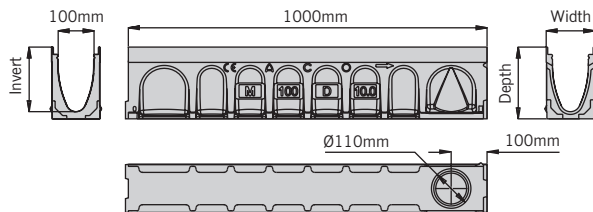

M100DS 0.5m constant depth channel 0.1j to 20.1j

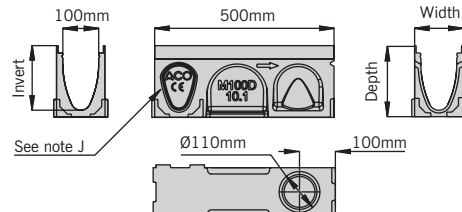

These products are subject to weight and dimensional tolerances. The dimensions shown on this page are for guidance purposes only.

ACO MultiDrain® MD channels

Product Code	Description	Length [mm]	Width Overall [mm]	Depth Overall [mm]	Invert Depth [mm]	Invert Type	Weight [kg]
M150DS constant depth channels with stainless steel edge rails							
24156	M150DS No. 0100	1000	185	100	75	1	16.7
24157	M150DS No. 0100V	1000	185	100	75	1	15.9
24150	M150DS No. 0.0*	1000	185	210	185	1/3	25.4
24153	M150DS No. 0.1]*	500	185	210	185	1/3	13.7
24151	M150DS No.10.0*	1000	185	260	235	1/3	28
24154	M150DS No. 10.1]*	500	185	260	235	1/3	15.6
24152	M150DS No.20.0*	1000	185	310	285	1/3	32.1
24155	M150DS No. 20.1]*	500	185	310	285	1/3	17.4

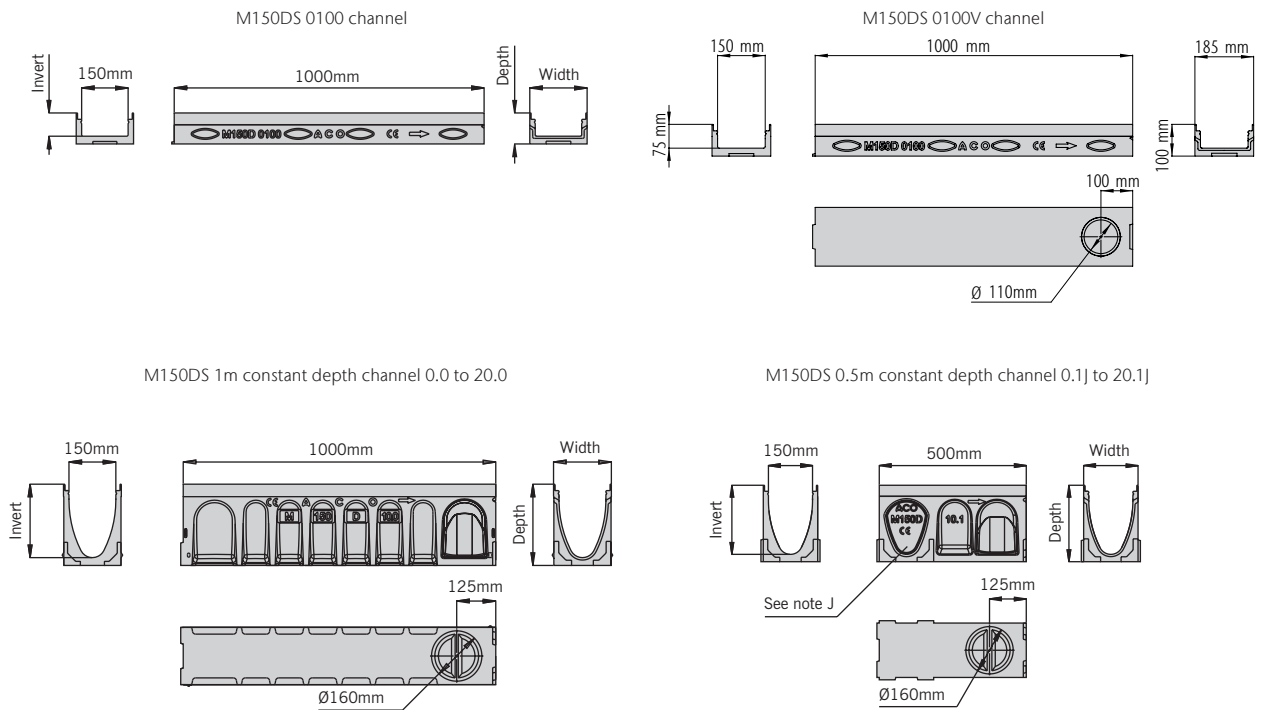

ACO MultiDrain® MD channels

Product Code	Description	Length [mm]	Width Overall [mm]	Depth Overall [mm]	Invert Depth [mm]	Invert Type	Weight [kg]
24216	M200DS No. 0100	1000	235	100	75	1	19.4
24217	M200DS No. 0100V	1000	235	100	75	1	18.7
24210	M200DS No. 0.0*	1000	235	265	240	1/3	34.8
24213	M200DS No. 0.1]*	500	235	265	240	1/3	18.9
24211	M200DS No.10.0*	1000	235	315	290	1/3	39.2
24214	M200DS No. 10.1]*	500	235	315	290	1/3	20.9
24212	M200DS No.20.0*	1000	235	365	340	1/3	42.2
24215	M200DS No. 20.1]*	500	235	365	340	1/3	22.9

M200DS constant depth channels with stainless steel edge rails

24216	M200DS No. 0100	1000	235	100	75	1	19.4
24217	M200DS No. 0100V	1000	235	100	75	1	18.7
24210	M200DS No. 0.0*	1000	235	265	240	1/3	34.8
24213	M200DS No. 0.1]*	500	235	265	240	1/3	18.9
24211	M200DS No.10.0*	1000	235	315	290	1/3	39.2
24214	M200DS No. 10.1]*	500	235	315	290	1/3	20.9
24212	M200DS No.20.0*	1000	235	365	340	1/3	42.2
24215	M200DS No. 20.1]*	500	235 </td <td>365</td> <td>340</td> <td>1/3</td> <td>22.9</td>	365	340	1/3	22.9

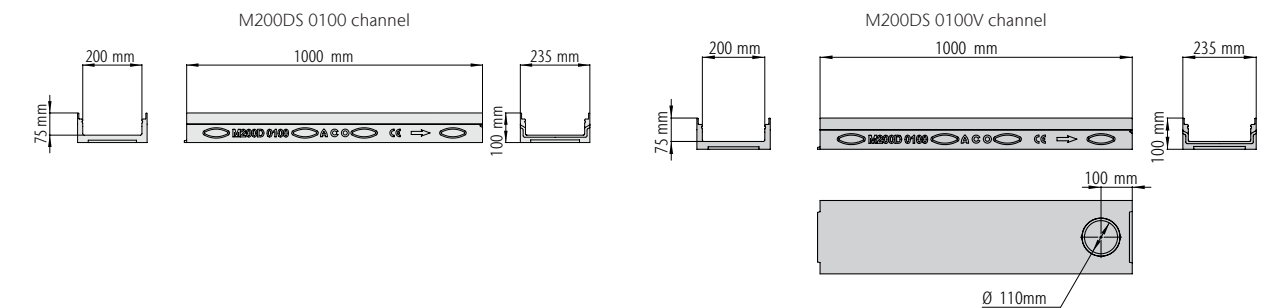

M200DS constant depth channel 0.0 to 20.0

M200DS 0.5m constant depth channel 0.1] to 20.1]

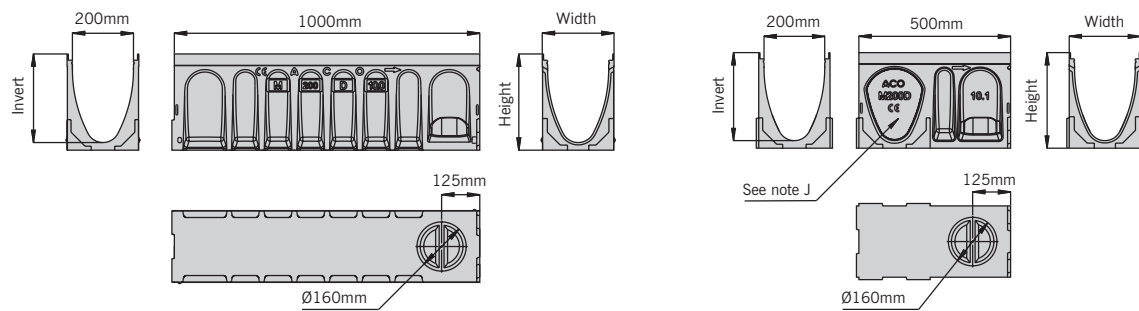

Note: The constant depth channels have an improved knock-out feature, see page 63 for more information.

* Indicates channels supplied with a preformed Ø160mm knock-out for vertical outlet.

J Indicates side knock-out for 90° channel connection. Knock-out on both sides of the channel.

V Indicates channel with cast in TPE triple lipped seals for water tight connection. See page 65 for further information.

These products are subject to weight and dimensional tolerances. The dimensions shown on this page are for guidance purposes only.

ACO MultiDrain® MD components

Product Code	Description	Length	Width Overall	Depth Overall	Invert Depth	Invert Type	Weight
		[mm]	[mm]	[mm]	[mm]		
Multifunctional endcap (closing/inlet/outlet)							
23404	M100D multifunctional endcap	-	135	75/300	50	-	0.2
23159	M150D multifunctional endcap	-	185	310/100	75	-	0.3
23219	M200D multifunctional endcap	-	235	365/100	75	-	0.4

The multifunctional endcap can be cut down to suit all channels. See page 42 for further information.

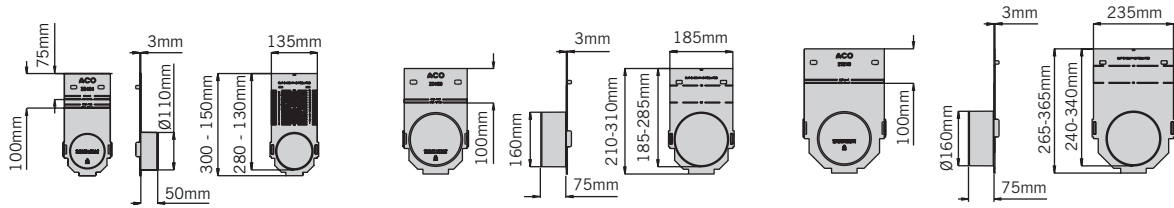

Step connector

12601	M100D 50mm Step connector	100	75	50	-	-	0.4
13001	M150D 50mm Step connector	100	98	50	-	-	0.5
13401	M200D 50mm Step connector	100	120	50	-	-	0.6

Note: For information on the Step connector functionality see page 64.

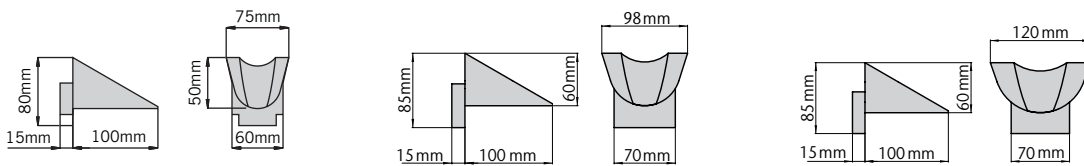

ACO MultiDrain® MD components

Product Code	Description	Length [mm]	Width Overall [mm]	Depth Overall [mm]	Invert Depth [mm]	Invert Type	Weight [kg]
--------------	-------------	----------------	--------------------------	--------------------------	-------------------------	----------------	----------------

M100DS Universal sump unit with stainless steel edge rails

24410	M100DS Universal sump with plastic silt bucket	500	135	635	615	-	33.9
-------	--	-----	-----	-----	-----	---	------

Standard sump outlets

- 1 = Ø110mm outlet with triple lipped seal
- 2 = Ø110mm knockout
- 3 = Ø160mm knockout

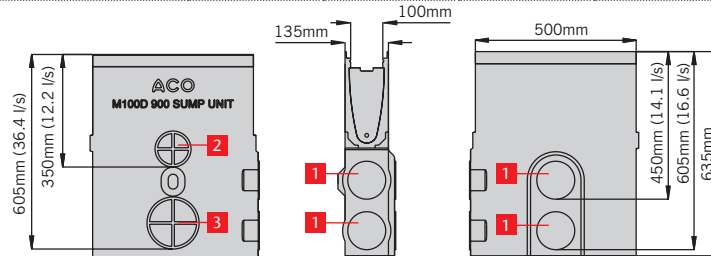

Note: Drawing shows flow through un-trapped unions. For information on the sump unit functionality see page 66.

M150DS Universal sump unit with stainless steel edge rails

24158	M150DS Universal sump with plastic silt bucket	500	185	735	715	-	44.5
-------	--	-----	-----	-----	-----	---	------

Standard sump outlets

- 1 = Ø110mm outlet with triple lipped seal
- 2 = Ø160mm knockout
- 3 = Ø200mm knockout

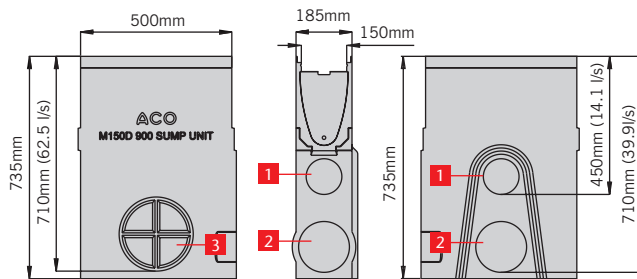

Note: Drawing shows flow through un-trapped unions. For information on the sump unit functionality see page 66.

M200DS Universal sump unit with stainless steel edge rails

24218	M200DS Universal sump with plastic silt bucket	500	235	790	765	-	48
-------	--	-----	-----	-----	-----	---	----

Standard sump outlets

- 1 = Ø110mm outlet with triple lipped seal
- 2 = Ø160mm knockout
- 3 = Ø200mm knockout

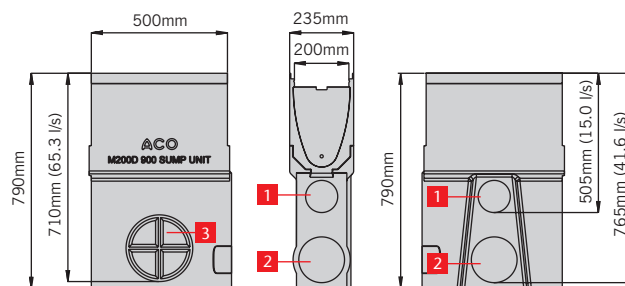

Note: Drawing shows flow through un-trapped unions. For information on the sump unit functionality see page 66.

Note: For ACO Universal gully details please refer to page 15. For Foul air trap details please refer to page 17.

For repair kit information please see page 17.

These products are subject to weight and dimensional tolerances. The dimensions shown on this page are for guidance purposes only.

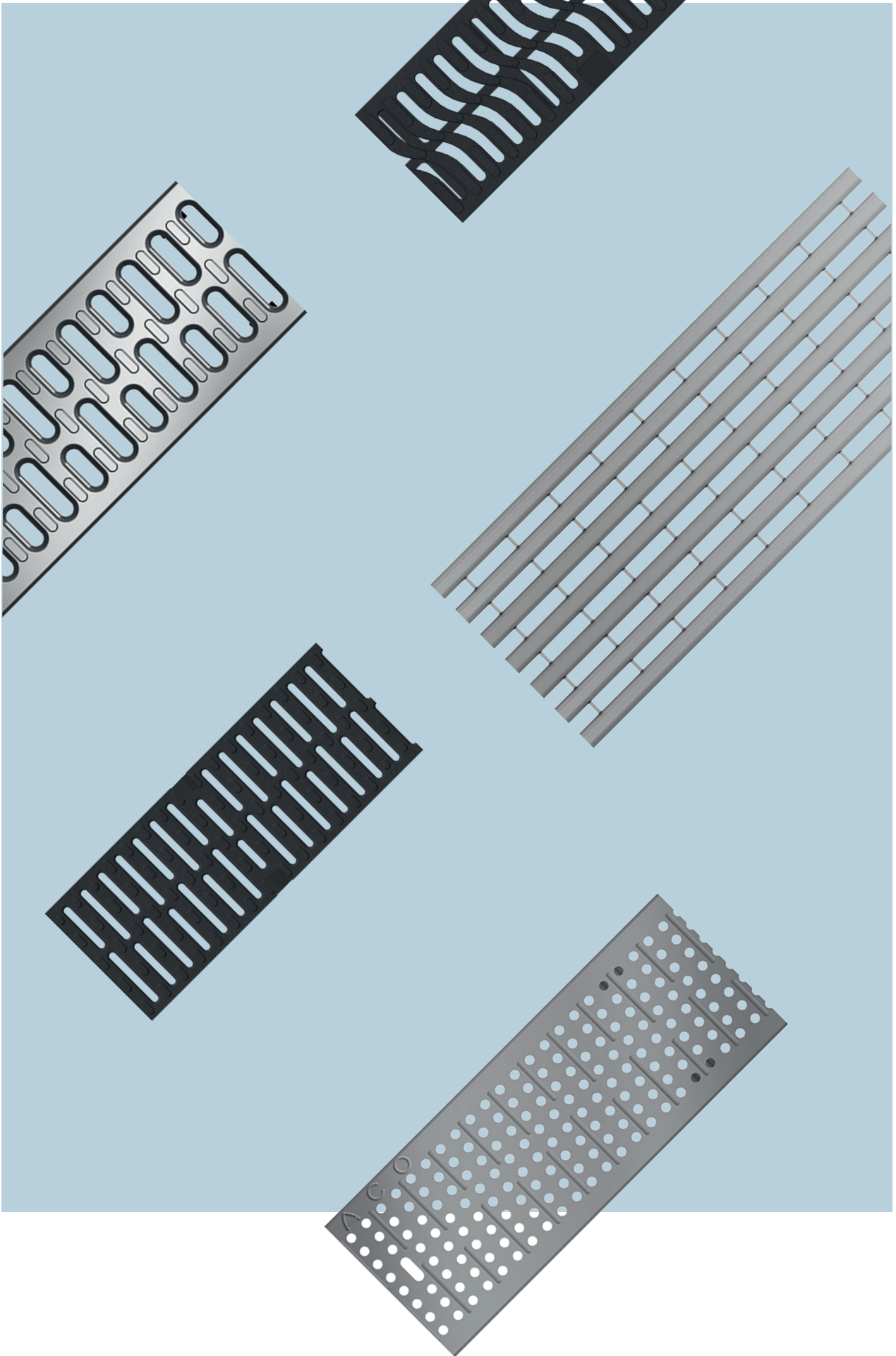

Gratings for use with ACO MultiDrain® channels with stainless steel edge rails

ACO MultiDrain® gratings range provides designers with a wide choice of styles to complete their surface water drainage system.

Stainless steel grates are compatible with stainless steel edged channels and are compatible with M100, M150 and M200 width units. They incorporate our unique ACO Drainlock™ fixings which improves hydraulic capacity of the channel.

The wide range of grating styles includes traditional Slotted, Perforated, Mesh, Profile and the elegant Bar grate. Tailored and discreet security locking assemblies are also available for added protection.

ACO Brickslot ST is a subtle and unobtrusive grating which when combined with an ACO MultiDrain® MD channel, can be used as a solution to complement discreet drainage applications and is ideal for use against buildings facades. Designed with a heelguard 10mm single offset drainage inlet, or a double Twinslot inlet in either offset or central.

Compatible with most paving materials, the vertical sides of the grating enable pavements to be laid directly to the unit's edge. Once installed the system is totally secure and not vulnerable to vandalism or loose grates making it a suitable for applications such as schools and playgrounds where grating removal can become a hazard.

The channel and ACO Brickslot ST grating together provide an unobtrusive continuous slot drainage system, with high hydraulic efficiency for fast removal of surface water. The system includes an ACO Brickslot ST access unit to ensure easy maintenance and access to the drainage system.

ACO Bespoke Brickslot is custom designed to suit specific customer requirements for MultiDrain 100, 150 and 200 channels. To accommodate specific sites, ACO Brickslot grates can be manufactured in different heights (30mm to 200mm) and also custom slot widths and



lengths (up to 1m). The Brickslot can be manufactured from mild steel with a hot dipped galvanised finish or stainless steel for increased corrosion resistance. Please contact your sales representative to discuss.

ACO MultiDrain® gratings are suitable for applications up to and including Load Class D 400 (This product is not suitable for carriageways of public roads or motorways).

Gratings for use with ACO MultiDrain® M100DS channels with stainless steel edge rails

Product Code	Description	Length [mm]	Width Overall [mm]	Depth Overall [mm]	Slot width/ hole dia [mm]	Heelguard™	Intake area (mm ² /m)	Anti shunt feature	Weight [kg]
--------------	-------------	----------------	-----------------------	-----------------------	---------------------------------	------------	-------------------------------------	--------------------	----------------

Gratings for Load Class A 15 applications

12640	Slotted stainless steel grate	1000	123	21	10	Yes	25300	n/a	2
12641	Slotted stainless steel grate	500	123	21	10	Yes	25300	n/a	1
12664	Perforated stainless steel grate	1000	123	21	6	Yes	16300	n/a	2.6
12665	Perforated stainless steel grate	500	123	21	6	Yes	16300	n/a	1.3

12640 / 12641

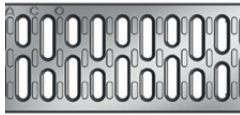

12664 / 12665

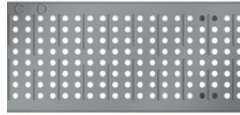

Gratings for Load Class B 125 applications

132557	Intercept Bar stainless steel grate Ø	1000	123	21	6	Yes	43000	Yes	3.8
132552	Intercept Bar stainless steel grate Ø	500	123	21	6	Yes	43000	Yes	1.9
132556	Intercept Profile stainless steel grate Ø	1000	123	21	8	Yes	44500	Yes	3.7
132551	Intercept Profile stainless steel grate Ø	500	123	21	8	Yes	44500	Yes	1.9

132557 / 132552



132556 / 132551



Product Code	Description	Length [mm]	Width Overall [mm]	Depth Overall [mm]	Slot width/ hole dia [mm]	Heelguard™	Intake area (mm ² /m)	Anti shunt feature	Weight [kg]
Gratings for Load Class C 250 applications									
12644	Slotted stainless steel grate	1000	123	21	10	Yes	25300	n/a	5
12645	Slotted stainless steel grate	500	123	21	10	Yes	25300	n/a	2.5
12654	Perforated stainless steel grate	1000	123	21	6	Yes	16300	n/a	4.8
12655	Perforated stainless steel grate	500	123	21	6	Yes	16300	n/a	2.4
132882	Heelguard™ mesh stainless steel grate Ⓜ	1000	123	21	9.5	Yes	79000	Yes	4.2
132883	Heelguard™ mesh stainless steel grate Ⓜ	500	123	21	9.5	Yes	79000	Yes	2.1

12644 / 12645

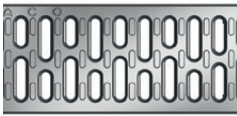

12654 / 12655

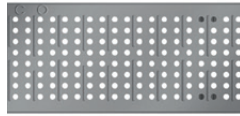

132882 / 132883



Product Code	Description	Length [mm]	Width Overall [mm]	Depth Overall [mm]	Slot width/ hole dia [mm]	Heelguard™	Intake area (mm ² /m)	Anti shunt feature	Weight [kg]
--------------	-------------	-------------	--------------------	--------------------	---------------------------	------------	----------------------------------	--------------------	-------------

Gratings for Load Class D400* applications

132887	Heelguard™ mesh stainless steel grate Ⓜ	1000	123	21	8.5	Yes	69100	Yes	5.2
132888	Heelguard™ mesh stainless steel grate Ⓜ	500	123	21	8.5	Yes	69100	Yes	2.5
446018	Brickslot ST stainless steel grate	1000	123	105	10	Yes	10000	n/a	7.2
446019	Brickslot ST stainless steel grate	500	123	105	10	Yes	10000	n/a	3.7
446020	Brickslot ST access unit stainless steel grate	500	123	105	10	Yes	10000	n/a	7.2
23490	Brickslot Twinslot offset stainless steel	1000	123	105	10	Yes	20000	n/a	13
23491	Brickslot Twinslot offset stainless steel	500	123	105	10	Yes	20000	n/a	6.5
23492	Brickslot Twinslot offset access unit stainless steel	500	123	105	10	Yes	20000	n/a	11.3
23493	Brickslot Twinslot central stainless steel	1000	123	105	10	Yes	20000	n/a	11.7
23494	Brickslot Twinslot central stainless steel	500	123	105	10	Yes	20000	n/a	5.8
23495	Brickslot Twinslot central access unit stainless steel	500	123	105	10	Yes	20000	n/a	14.2

132887 / 132888

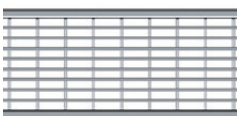

446018 / 446019

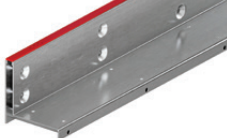

446020



23493 / 23494



23495

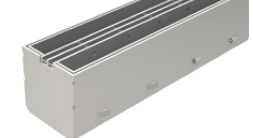

Ⓜ Indicates security locking available.

* Not suitable for carriageways of public roads or motorways

** Standard Allen key required

Note: 1m grates require 2pcs of Security locking assemblies and 0.5m grates require 1pc

Product Code	Description	For use with	Length [mm]	Width Overall [mm]	Depth Overall [mm]	Weight [kg]
Grating accessories						
445828	Drainlock™ security locking assembly Mesh** C250	132882, 132883	96	20	13	0.1
445745	Drainlock™ security locking assembly Mesh** D400	132887, 132888	96	27	13	0.1
445830	Drainlock™ security locking assembly Profile**	132551, 132556	96	27	13	0.1
445829	Drainlock™ security locking assembly Bar**	132552, 132557	96	27	13	0.1
1367	Drainlock™ grating lifting tool	all	400	150	6	0.2

445828 Drainlock™ security locking assembly Mesh**

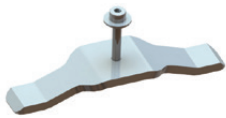

445830 Drainlock™ security locking assembly Profile**

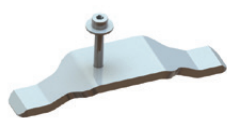

445829 Drainlock™ security locking assembly Bar**

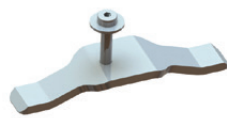

1367 Drainlock™ grating lifting tool 835



**Standard Allen key required.

Gratings for use with ACO MultiDrain® M150DS channels with stainless steel edge rails

Product Code	Description	Length [mm]	Width Overall [mm]	Depth Overall [mm]	Slot width/ hole dia [mm]	Heelguard™	Intake area (mm ² /m)	Anti shunt feature	Weight [kg]
--------------	-------------	----------------	-----------------------	-----------------------	---------------------------------	------------	-------------------------------------	--------------------	----------------

Gratings for Load Class B 125 applications

133603	Heelguard™ mesh stainless steel grate 6	1000	173	36	10	Yes	118200	Yes	5.5
133604	Heelguard™ mesh stainless steel grate 6	500	173	36	10	Yes	118200	Yes	2.7
133627	Intercept-Profile stainless steel grate 6	1000	173	30	9	Yes	68700	Yes	5.1
133628	Intercept-Profile stainless steel grate 6	500	173	30	9	Yes	68700	Yes	2.6
133633	Intercept-Bar stainless steel grate 6	1000	173	27	6	Yes	66800	Yes	5.5
133634	Intercept-Bar stainless steel grate 6	500	173	27	6	Yes	66800	Yes	2.8

133603 / 133604



133627 / 133628

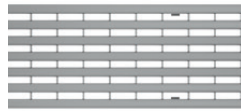

133633 / 133634



Gratings for Load Class C 250 applications

133607	Heelguard™ mesh stainless steel grate 6	1000	173	40	10	Yes	118200	Yes	5.7
133608	Heelguard™ mesh stainless steel grate 6	500	173	40	10	Yes	118200	Yes	2.9

133607 / 133608

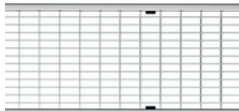

Product Code	Description	Length [mm]	Width Overall [mm]	Depth Overall [mm]	Slot width/ hole dia [mm]	Heelguard™	Intake area (mm ² /m)	Anti shunt feature	Weight [kg]
--------------	-------------	-------------	--------------------	--------------------	---------------------------	------------	----------------------------------	--------------------	-------------

Grating for Load Class D 400* applications

133611	Heelguard™ mesh stainless steel grate 6	1000	173	46	10	Yes	103400	Yes	8
133612	Heelguard™ mesh stainless steel grate 6	500	173	46	10	Yes	103400	Yes	4
446030	Brickslot ST stainless steel grate	1000	173	105	10	Yes	10000	n/a	8.7
446031	Brickslot ST stainless steel grate	500	173	105	10	Yes	10000	n/a	4.5
446032	Brickslot ST access unit stainless steel grate	500	173	105	10	Yes	10000	n/a	9.1

133611 / 133612



446030 / 446031



446032



Product Code	Description	For use with	Length [mm]	Width Overall [mm]	Depth Overall [mm]	Weight [kg]
--------------	-------------	--------------	-------------	--------------------	--------------------	-------------

Grating accessories

445831	Drainlock™ security locking assembly Mesh**	133603, 133604, 133607, 133608, 133611, 133612	146	20	13	0.1
445833	Drainlock™ security locking assembly Profile**	133627, 133628	146	27	13	0.1
445832	Drainlock™ security locking assembly Bar**	133633, 133634	146	27	13	0.1
1367	Drainlock™ grating lifting tool	all	400	150	6	0.2

445831 Drainlock™ security locking assembly Mesh**



445833 Drainlock™ security locking assembly Profile**



445832 Drainlock™ security locking assembly Bar**

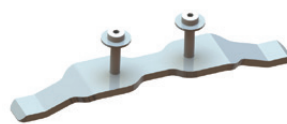

1367 Drainlock™ grating lifting tool 835



6 Indicates security locking available.

* Not suitable for carriageways of public roads or motorways

** Standard Allen key required

Note: 1m grates require 2pcs of Security locking assemblies and 0.5m grates require 1pc

These products are subject to weight and dimensional tolerances. The dimensions shown on this page are for guidance purposes only.

Gratings for use with ACO MultiDrain® M200DS channels with stainless steel edge rails

Product Code	Description	Length [mm]	Width Overall [mm]	Depth Overall [mm]	Slot width/ hole dia [mm]	Heelguard™	Intake area (mm ² /m)	Anti shunt feature	Weight [kg]
--------------	-------------	----------------	-----------------------	-----------------------	---------------------------------	------------	-------------------------------------	--------------------	----------------

Gratings for Load Class B 125 applications

133615	Heelguard™ mesh stainless steel grate B	1000	223	40	10	Yes	157500	Yes	7.3
133616	Heelguard™ mesh stainless steel grate B	500	223	40	10	Yes	157500	Yes	3.7
133631	Intercept-Profile stainless steel grate B	1000	223	39	8	Yes	84600	Yes	7.4
133632	Intercept-Profile stainless steel grate B	500	223	39	8	Yes	84600	Yes	3.6
133635	Intercept-Bar stainless steel grate B	1000	223	35	6	Yes	86600	Yes	8
133636	Intercept-Bar stainless steel grate B	500	223	35	6	Yes	86600	Yes	4

133615 / 133616



133631 / 133632

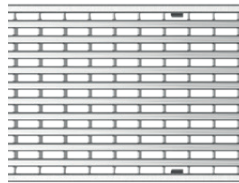

133635 / 133636



Gratings for Load Class C 250 applications

133619	Heelguard™ mesh stainless steel grate C	1000	223	46	10	Yes	137700	Yes	10.7
133620	Heelguard™ mesh stainless steel grate C	500	223	46	10	Yes	137700	Yes	5.3

133619 / 133620

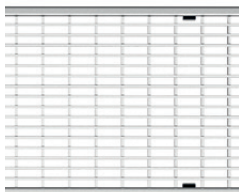

Product Code	Description	Length [mm]	Width Overall [mm]	Depth Overall [mm]	Slot width/hole dia [mm]	Heelguard™	Intake area (mm ² /m)	Anti shunt feature	Weight [kg]
--------------	-------------	-------------	--------------------	--------------------	--------------------------	------------	----------------------------------	--------------------	-------------

Grating for Load Class D 400* applications

133623	Heelguard™ mesh stainless steel grate 6	1000	223	65	10	Yes	137700	Yes	13
133624	Heelguard™ mesh stainless steel grate 6	500	223	65	10	Yes	137700	Yes	6.5
446042	Brickslot ST stainless steel grate	1000	223	105	10	Yes	10000	n/a	8.1
446043	Brickslot ST stainless steel grate	500	223	105	10	Yes	10000	n/a	4.1
446044	Brickslot ST access unit stainless steel grate	500	223	105	10	Yes	10000	n/a	10.3

133623 / 133624



446042 / 446043

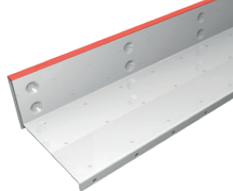

446044



Product Code	Description	For use with	Length [mm]	Width Overall [mm]	Depth Overall [mm]	Weight [kg]
--------------	-------------	--------------	-------------	--------------------	--------------------	-------------

Grating accessories

445834	Drainlock™ security locking assembly Mesh**	133615, 133616, 133619, 133620, 133623, 133624	195	20	13	0.1
445836	Drainlock™ security locking assembly Profile**	133631, 133632	195	27	13	0.1
445835	Drainlock™ security locking assembly Bar**	133635, 133636	195	27	13	0.1
1367	Drainlock™ grating lifting tool	all	400	150	6	0.2

445834 Drainlock™ security locking assembly Mesh**



445836 Drainlock™ security locking assembly Profile**



445835 Drainlock™ security locking assembly Bar**



1367 Drainlock™ grating lifting tool 835



6 Indicates security locking available.

* Not suitable for carriageways of public roads or motorways

** Standard Allen key required

Note: 1m grates require 2pcs of Security locking assemblies and 0.5m grates require 1pc

These products are subject to weight and dimensional tolerances. The dimensions shown on this page are for guidance purposes only.

Channel footpath drainage



Channel footpath drainage is specifically used where roof drainage from downpipes is required to cross the footpath into the road gutter. Combining an ACO Downpipe connector and ACO Kerb outlet with ACO MultiDrain® M100D/M100DS channel creates a safer method for water to cross pedestrian areas.

The system can be installed with either a grated channel or solid cover and is suitable for Load Class D 400 applications. The high load class is required as vehicles may occasionally mount the kerb, and ACO's channel footpath drainage has been designed to withstand these loads.

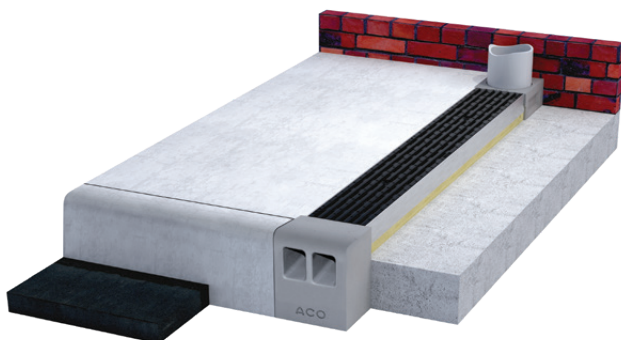

Load Class

Channel footpath drainage

The ACO MultiDrain® M100D/M100DS system includes a range of accessories which provide a drainage solution ideal for areas where down pipes from roofs and gutters exit on to the pavement. The ACO channel footpath drainage system effectively carries water away from paved areas and across into the adjacent carriageway.

The system uses ACO MultiDrain® M100D/M100DS shallow depth channels and has two types of kerb outlets and downpipe connectors to suit application requirements.

Shallow channels

ACO MultiDrain® MD shallow depth channels are available in two sizes, 75mm and 100mm total depths (ACO M100D / M100DS 075 and ACO M100D / M100DS 0100) and have the option of galvanised or stainless steel edge rails.

Downpipe connectors

Two downpipe connectors are available to suit channel depth. Manufactured from grey polymer concrete the downpipe connector has a clear opening of Ø75mm and connects to downpipes with outside diameters of up to 82mm.

Kerb outlets

Two outlets are available to suit the kerb profile of the application, a CFD half battered kerb outlet to suit standard HB kerbs and a CFD bull nose kerb outlet to match BN kerbs. Manufactured from grey polymer concrete the kerb outlets allow rainwater to discharge into the road gutter from this system.

Gratings

Traditionally solid ductile iron covers are selected in channel footpath drainage applications but all ACO MultiDrain® M100D/M100DS gratings are suitable for use with this system. The system's load class rating is determined by the grating selected, further information of gratings within the range can be found on pages 34-43 and 50-58.

Product Code	Description	Length [mm]	Width Overall [mm]	Depth Overall [mm]	Invert Depth [mm]	Invert Type	Weight [kg]
ACO MultiDrain® M100D shallow depth channels with UltraSTEEL™ galvanised edge rails							
23075	M100D No. 075	1000	135	75	55	1	9.2
23076	M100D No. 075V	1000	135	75*	55	1	8.9
23110	M100D No. 0100	1000	135	100	80	1	11
23111	M100D No. 0100V	1000	135	100*	80	1	10.7
ACO MultiDrain® M100DS shallow depth channels with stainless steel edge rails							
24075	M100DS No. 075	1000	135	75	55	1	10.9
24076	M100DS No. 075V	1000	135	75*	55	1	10.6
24110	M100DS No. 0100	1000	135	100	80	1	12.7
24111	M100DS No. 0100V	1000	135	100*	80	1	12.4

Note: V Indicates channel with cast in triple lipped seals for water tight connection. See page 41 for further details.

* 075V and 0100V channels have a depth overall around the outlet of 80mm (075V) and 105 (0100V).

These products are subject to weight and dimensional tolerances. The dimensions shown on this page are for guidance purposes only.

Product Code	Description	Length [mm]	Width Overall [mm]	Depth Overall [mm]	Invert Depth [mm]	Invert Type	Weight [kg]
Downpipe connectors							
23450	CFD075 downpipe connector grey	150	135	75	n/a	n/a	2.4
23451	CFD0100 downpipe connector grey	150	135	100	n/a	n/a	3

CFD 075 downpipe connector

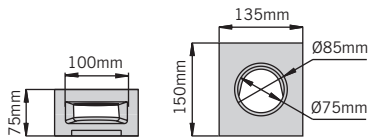

CFD 0100 downpipe connector

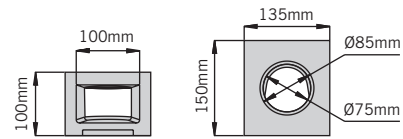

Kerb outlet profiles

23452	CFD kerb outlet half batter grey	125	135	225	n/a	n/a	6.7
23453	CFD kerb outlet bull nose grey	125	135	225	n/a	n/a	7

CFD kerb outlet half batter

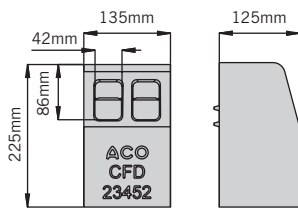

CFD bull-nose kerb outlet

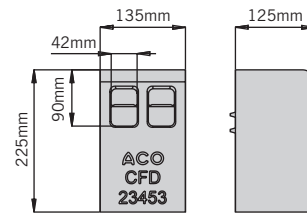

ACO Downpipe connectors for use with the MultiDrain systems

The ACO rainwater downpipe channel connector is an effective method for connecting downpipes directly into the channel body, eliminating the risk of blockages and allowing full flow.

The connector is maintenance friendly and can be easily lifted from the channel to clear localised blockages without the need to lift the entire grating. The connector can be positioned in line or perpendicular to the channel depending on the installation location and has an overhang lip to hide the cut edge of the adjacent grating – resulting in a tidy and safe installation.

The connector is offered in a range of sizes and colours for circular or square downpipes. The connectors can be used on a variety of channels including MultiDrain, MultiDrain PPD and Multiline Sealin.

Details of the MultiDrain PPD and Multiline Sealin ranges can be found on the ACO website: www.aco.co.uk

- Direct connection into the channel eliminating blockages in the grating
- Quick and simple installation
- Easy maintenance
- Sizes, shapes and colours to suit most downpipes and installations



Product Code	Description	Length [mm]	Width Overall [mm]	Depth Overall [mm]	Weight [kg]
Black Downpipe connectors					
27132	Downpipe connector, M100D/PPD Ø68mm*	142	133	60	1.07
27138	Downpipe connector, M100D/PPD □65mm*	142	133	60	1.04
27150	Downpipe connector, M150D/PPD Ø110mm	192	183	60	1.65
27152	Downpipe connector, M150D/PPD □100mm	192	183	60	1.66
27155	Downpipe connector, M200D/PPD Ø110mm	242	233	60	2.58

Grey Downpipe connectors					
27133	Downpipe connector, M100D/PPD Ø68mm*	142	133	60	1.07
27139	Downpipe connector, M100D/PPD □65mm*	142	133	60	1.04
27151	Downpipe connector, M150D/PPD Ø110mm	192	183	60	1.65
27153	Downpipe connector, M150D/PPD □100mm	192	183	60	1.66
27154	Downpipe connector, M200D/PPD Ø110mm	242	233	60	2.58

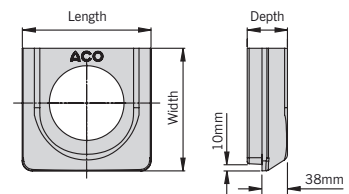
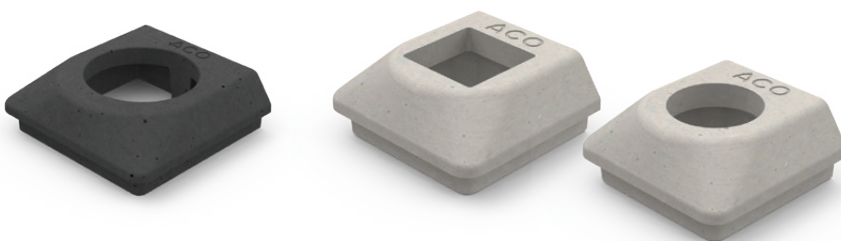

*Also compatible with ACO HexDrain Pro and ACO CivicDrain
 These products are subject to weight and dimensional tolerances.
 The dimensions shown on this page are for guidance purposes only.

Preparing the system for installation

Channel base knockout details

The ACO rainwater downpipe channel connector is an effective method for connecting downpipes directly into the channel body, eliminating the risk of blockages and allowing full flow.

The connector is maintenance friendly and can be easily lifted from the channel to clear localised blockages without the need to lift the entire grating. The connector can be positioned in line or perpendicular to the channel depending on the installation location and has an overhang lip to hide the cut edge of the adjacent grating – resulting in a tidy and safe installation.

The connector is offered in a range of sizes and colours for circular or square downpipes. The connectors can be used on a variety of channels including MultiDrain, MultiDrain PPD and Multiline Sealín.

Knockout detail

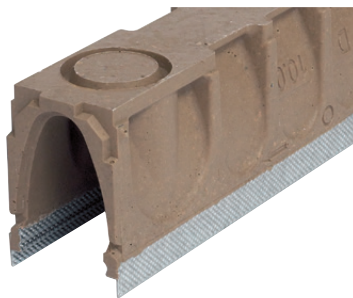

Function

STEP 1: Pre formed knockout detail

STEP 2: Support channel around knockout detail by placing the channel on sand or soft earth for example. Tap the knockout panel from the side indicated by the Hammer symbol to remove panel.

STEP 3: Push fit pipe into recess provided and seal as required. For recommended sealants refer to the section headed “watertight sealing”.



Channel side wall connection detail

An additional feature provided on all 500mm long channels are removable side wall panels, which allow channel runs to be connected together to form “T” or “L” junctions for continuous water flow through the system. Where channel connections are to be made to the side wall of these units a female joint detail is provided to aid alignment and fast installation.

Removable side wall panel



Function

STEP 1: Using a disc cutter as shown, cut a cross into the panel provided. Ensure cuts extend to but not beyond the perimeter recess surrounding the removable panel.

STEP 2: Tap segments of panel between the cuts to remove the panel.

STEP 3: Use a chisel to tidy up any remaining material. Channel connection can now be made and sealed as required.



Shallow Channels

The ACO MultiDrain® MD shallow channels are available in either 75mm or 100mm overall depths. These units are ideal for use where installation depths are restricted such as in structural slabs, bridge decks and roofs. All units can be sealed for watertight installations as each unit is supplied with a preformed sealant groove (see section headed watertight sealing for further details).

The shallow channels identified with a “V” such as the 075V and 0100V units have a cast-in triple lipped seal in their base for push fit watertight connections to Ø110mm PVC-U pipe. These triple lipped seals are manufactured from SEBS-TPE and have excellent chemical, UV and weather resistance.



Step connector

Each width of MultiDrain® MD has available a Step connector manufactured from polymer concrete. This unit is used between constant depth channel joints where a stepped fall channel installation is required and takes up the 50mm height difference between units. The Step connector ensures a smooth water flow within the channel system.



Function

STEP 1: Ensure triple lipped seal and pipe spigot are clean and free from debris.

STEP 2: Lubricate joint faces as required and push fit pipe into the seal. The pipe is fully fitted when the end of the pipe is flush with the internal base of the channel.



Function

STEP 1: Place Step connector into the base of the deeper channel to be joined as shown.

STEP 2: Push channel joint together to lock Step connector in place forming a smooth transition between units as shown.



Watertight sealing

ACO MultiDrain® MD channels are generally installed without a particular water seal. Once butt jointed and with a concrete surround a fairly watertight installation is achieved. If however a water tight system is required each MultiDrain® MD channel is provided with a sealant groove allowing the system to be sealed by the application of a flexible sealant either during or following installation.

For rainwater applications we recommend a single component, polyurethane based elastomeric joint sealant such as BASF Masterflex 472 or Sika Sikaflex 11FC or similar.

Application of sealant to be in accordance with the sealant manufacturers recommendations, but for guidance a typical method of application is as follows.

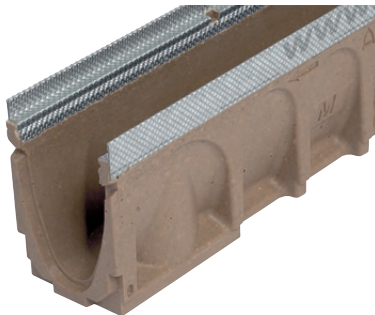

Function

STEP 1: Jointing faces of the channels to be sound and cleaned to remove all loose material, dust, oil and grease. This can be done by the use of a wire brush.



STEP 2: Butt joint the channels & install as per ACO installation instructions. Ensuring joints are still clean and dry, apply sealant with a cartridge gun approximately 5mm thick to the end face of the channel & completely fill the sealant groove.

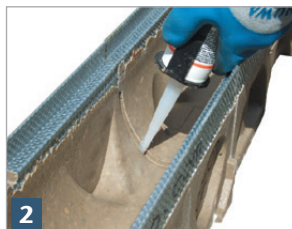

STEP 3: Wipe excess sealant from the inside faces of the channel & inspect sealant groove to ensure it has been fully filled with sealant. Leave sealant to cure before use as per the sealant manufactures recommendations.



Multifunctional endcap

A Multifunctional endcap is provided for each channel width that is designed to be used with all channel heights in each range. Manufactured from polypropylene these versatile endcaps can be adjusted on site to perform the function of a closing endcap or as an inlet/outlet endcap for connection to Ø110mm (100mm wide bore) or Ø160mm (150mm and 200mm wide bore) PVC-U pipe.

Cutting guide

Removable knockout panel



Function

CLOSING ENDCAP:

The endcap supplied fits directly to the deepest channel within the system. All other channel heights can be accommodated by simply cutting the endcap to suit. A cutting guide is printed on the front of the endcap plate.

The endcap is fastened to the channel by two clips and can be connected to either male or female channel end.

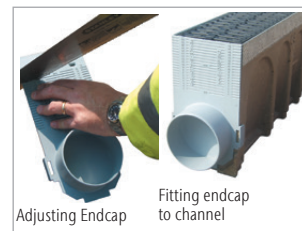

INLET & OUTLET ENDCAP:

The endcap has a knockout panel which can be removed with a hammer. It is designed to provide a connection to Ø110mm (100mm wide bore) or Ø160mm (150mm and 200mm wide bore) PVC-U pipes.



Sump unit

A polymer concrete chamber unit which provides the capacity to hold water and silt, and also provides an outlet for the channel system.

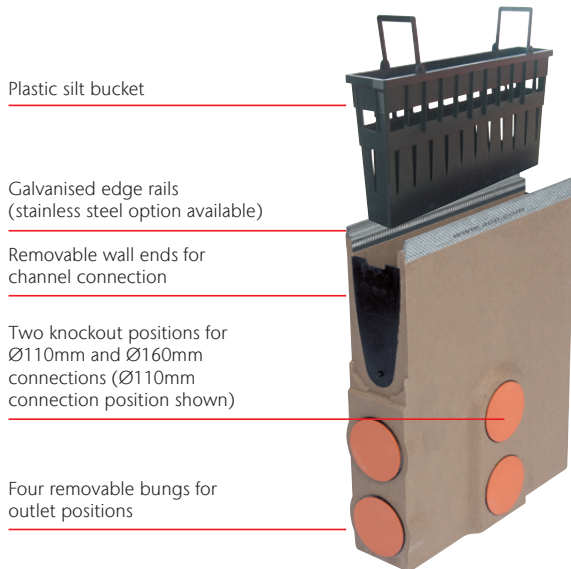

Roddable foul air traps

A drain connector available in Ø110mm and Ø160mm for connection to foul or combined drainage. Foul air traps come complete with removable bung for rodding and are manufactured from highly durable recyclable MDPE.



Ø160mm foul air trap



Ø110mm foul air trap

Function

STEP 1: Triple lipped seals for watertight connections.

STEP 2: Unit wall ends can easily be removed using knife or saw.

STEP 3: Two knockouts for Ø110mm and Ø160mm pipe connections. For knockout removal refer to method stated on page 45 headed 'Channel side wall connection detail'.

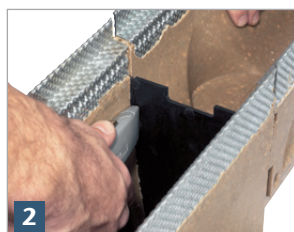

Function

STEP 1: Push the foul air trap into place.

STEP 2: Bung can be removed for rodding



ACO Universal Gully

A recycled plastic & ductile iron modular system purposely designed for use with ACO channel drainage systems up to 200mm internal width. The system provides a high capacity for retaining water and also an outlet for the drainage system.



Ductile cast iron locked cover

Cutting guide to suit most ACO channels

Silt bucket

Gully base including roddable foul air trap

Function

STEP 1: Once installed ACO Universal gully can be cut to match channel depth.

STEP 2: The cut ACO Universal gully matches the profile of the ACO MultiDrain® MD channel.

Note: Full installation details are available to download from www.aco.co.uk



Polymer concrete repair kit

ACO's Polymer concrete repair kit is available for bonding applications, for instance where a mitred channel joint is to be made or for the repair of small areas of aesthetic damage.



Function

STEP 1: Read enclosed safety and method sheet.

STEP 2: Apply polymer to clean dry surface and join the two surfaces. Smooth interior surface.

Repair kit not suitable for structural repairs



ACO Drainlock™ Gratings

ACO Drainlock™

Fitted as standard to ACO MultiDrain® MD gratings, this fast locking device removes the need for bolts and bars and improves the channels hydraulic capacity. The Drainlock™ mechanism simply clips into the channel edge rail for rapid installation. An installation guide is shown opposite.



Anti-shunt mechanism

A selection of the ACO Drainlock™ gratings are fitted with an anti-shunt mechanism that restricts unwanted grating movement when installed.



Function

- Push or stand on the grating until it clicks into place.
- To install, align the grating onto the channel. Align anti-shunt detail with recess.
- ACO Drainlock™ locking mechanism fastens into the channel. Gratings should be fitted in the channels before the installation concrete is installed.



Function

- The anti-shunt lines the grate up to the channel and prevents the grates ability to move linearly. When cutting channels to required lengths, remember to also align the grate to the channel so the anti-shunt engages.
- If your installation requires the channel to be cut or mitred, ensure the grate still aligns with the anti-shunt. Photo shows a poor quality installation where the grate overlaps the channel junction.

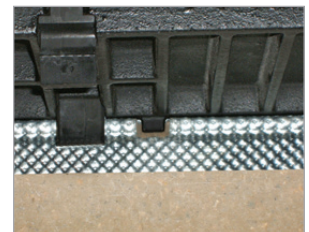

Removal of grating

It is recommended that all ACO grates are lifted with our Drainlock™ lifting tool, which allows quick and easy lifting of the grate close to the Drainlock™ mechanism.



Security locking

In areas such as schools and prisons, where unwanted grating removal needs to be restricted, a security locking can be used in conjunction with the following gratings; and options are available for most styles of galvanised and stainless steel grates. The system is fitted to the gratings by one or two M5/M6 screws and clamps the grating in place preventing removal. Security locking key for installation and removal supplied separately.



Function

- Insert tool as shown.
- Drainlock™ lifting tool available part no 1367.
- Pull upwards to unlock grating.



Function

- For ductile iron grates, fix the security screws and clamp the grating as shown.
- Place grating into the channel and tighten the fixing using the security locking key. Galvanised and stainless steel grate's security locking must be expanded rather than tightened to press against the Drainlock™ mechanism. Please refer to the product tables for more information.



Maintenance of ACO MultiDrain®

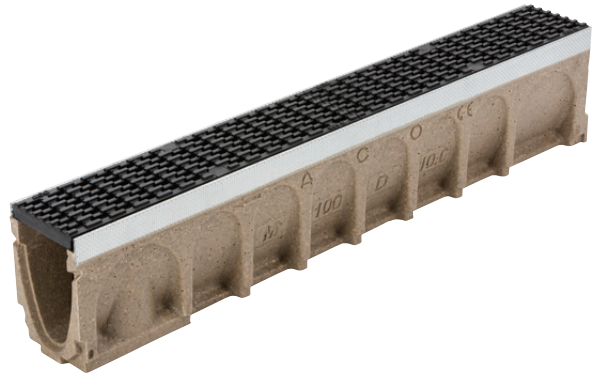

Method

- 1** Remove access unit top.
- 2** Position the jetting unit near the access unit or gully.
- 3** Attach a suitable jetting head and insert into access unit, towards the direction of travel. In this example a 1 inch (25mm) diameter tandem jetting head with forward and backward facing jets was used.
- 4** Introduce a 3-6 inch (75-150mm) suction hose into the adjacent gully/outlet.
- 5** This suction hose will remove the silt/detritus that the jetting hose flushes out.
- 6** Introduce the jet into the sump/access unit, facing the direction of channel section which is to be cleaned.
- 7** Activate the suction hose and jetting hose. A suitable initial jetting pressure is 80 bar or 1160 psi.
- 8** As the jetting head travels up the length of the channel, place boards or other suitable material over the channel grates to prevent the escape of water (spray back) and protect any vehicles or nearby property.
- 9** The jetting head will be propelled to the end of the channel or a determined length. When it reaches the end, increase the pressure to 150 bar (2176 psi).
- 10** Use a hydraulic winch to pull the jetting head backwards toward the access unit. The suction hose previously inserted in the gully/outlet will remove the water and detritus.
- 11** If a reduction of 'spray back' is required reduce the pressure to 80 bar (1160 psi). This pressure will still be sufficient to clean the channel.
- 12** If cleaning brickslot, pressure jet down through the slot with a standard hand held attachment, and repeat the flushing of the channel.
- 13** Replace the silt bucket and grate/access lid, and secure.



Lifting grates

When lifting gratings, use the Drainlock™ grating lifting tool (part number 1367). Insert the tool in from the end of the grate as shown, and gently lift the grate until the Drainlock™ clips release taking care not to bend or damage the grate.

Lifting with/without the lifting tool at the end of a grate, may result in damage/bending of the grate (particularly the composite and steel gratings). Always lift closer to the Drainlock™ clips as shown.



Access to Brickslot

Drainlock™ grating lifting tool



To remove the ACO Brickslot access unit tray, insert two lifting tools as shown.



Then lift the tray vertically from the frame.

Be aware that this unit complete with surfacing material, may be very heavy and safety precautions should be taken.



Further Learning

ACO Professional Development

ACO has recognised that knowledge transfer is fundamental in keeping up-to-date with the latest advancements in surface water management and has a unique training offer that can be accessed online, in-house or at the state-of-art training facility at the ACO Academy.

In Company

ACO offers face-to-face professional development sessions. These are carefully designed to last up to 1 hour, so they can be undertaken across a lunch break.



A member of our team will contact you directly to discuss your requirements and will tailor the session to meet your needs.

Webinars

ACO has developed a series of webinars that will keep you up to date, bringing you technical expertise as well as more specific product information. Whatever your involvement from specification to installation, there will be a webinar to meet your needs and further your learning.



ACO Academy Days

ACO's training facility at its UK head office in Bedfordshire has a theatre-style facility that can hold up to 50 people as well as a number of breakout rooms for small groups.



Professional development training can be combined with more in-depth product training at the on-site learning zone.

Seminars

ACO is bringing the experts to you via our programme of regional events, and by sharing information from key influencers within the industry as well as more specific product information. ACO's seminar events will include opportunities to enhance existing knowledge as well as network and discuss thoughts and ideas with other delegates.



www.aco.co.uk/professional_development | email: ukprofessionaldevelopment@aco.co.uk



Case Studies

ACO has operated in the UK for over 30 years and in this time we have worked on ground breaking projects that have pushed the boundaries of surface water management. Our case studies provide bite sized information that counts towards your professional development and can provide inspiration for future projects.

www.aco.co.uk/case-studies



Colab

Colab is a collaboration of partnerships, bringing together CPD and self-certified content to ensure that knowledge is shared and accessible to the construction industry. Visit our content and CPD partner website: Colab to see more professional development content from partners such as ACO, FutureBuild, CIHT, The Edge, and CIWEM.

www.colab-cpd.co.uk



askACO

train | design | support | care





-
- [ACO Water Management](#)
[Civils + Infrastructure](#)
[Building + Landscape](#)
 - [ACO Building Drainage](#)
 - [ACO Access](#)
 - [ACO Sport](#)
 - [ACO Wildlife](#)
-

ACO Water Management

A division of ACO Technologies plc

ACO Business Park
Hitchin Road
Shefford
Bedfordshire
SG17 5TE

Tel: 01462 816666
Sales: customersupport@aco.co.uk
Project pricing: awmprojects@aco.co.uk
Technical: technical@aco.co.uk

www.aco.co.uk

**ACO. creating
the future of drainage**

