

PROJECT-SPECIFIC
INSTRUCTIONS
INCLUDED WITH
YOUR DELIVERY

How to build with WoodBlocX

General building guide

WOOD
BlocX
LANDSCAPING

0800 389 1420 | hello@woodblocx.co.uk

Our modular timber system

Thank you for reading our general building guide, on the next few pages you will find all of the information you need about building with WoodBlocX.

Printed layer-by-layer building instructions are included with your material delivery.

WoodBlocX is made from sustainable, pressure-treated timber which is built to last for 20+ years. To maximise the lifespan of the structure you must build on a suitable and level surface. We strongly recommend installing a protective liner and adding a drainage layer in all of our structures.

Over the last 20 years, we're proud to have supplied thousands of commercial projects across the UK and throughout Europe. We hope you and your team enjoy building with WoodBlocX!

If you have any questions or require building support, give us a call: **0800 389 1420** or email us: **hello@woodblocx.co.uk**



Henry Blake

WoodBlocX Owner



WOOD
BlocX
LANDSCAPING

Contents

<u>Starting your build</u>	Page 4
<u>Levelling your build</u>	Page 5
<u>Building on soft ground</u>	Page 6
<u>Building on hard ground</u>	Page 8
<u>Connecting each layer together</u>	Page 10
<u>Using the dowel removal tool</u>	Page 11
<u>Installing a liner - best practice</u>	Page 12
<u>Final layer dowels</u>	Page 13
<u>Installing angle corner plates</u>	Page 14
<u>Adding the capping layer</u>	Page 15
<u>If your design includes buttresses</u>	Page 16
<u>If your design includes curves</u>	Page 17
<u>If your design includes 45° BlocX</u>	Page 18
<u>Building seating</u>	Page 19
<u>Building retaining walls</u>	Page 20
<u>Building steps</u>	Page 22
<u>WoodBlocX colour code</u>	Page 23

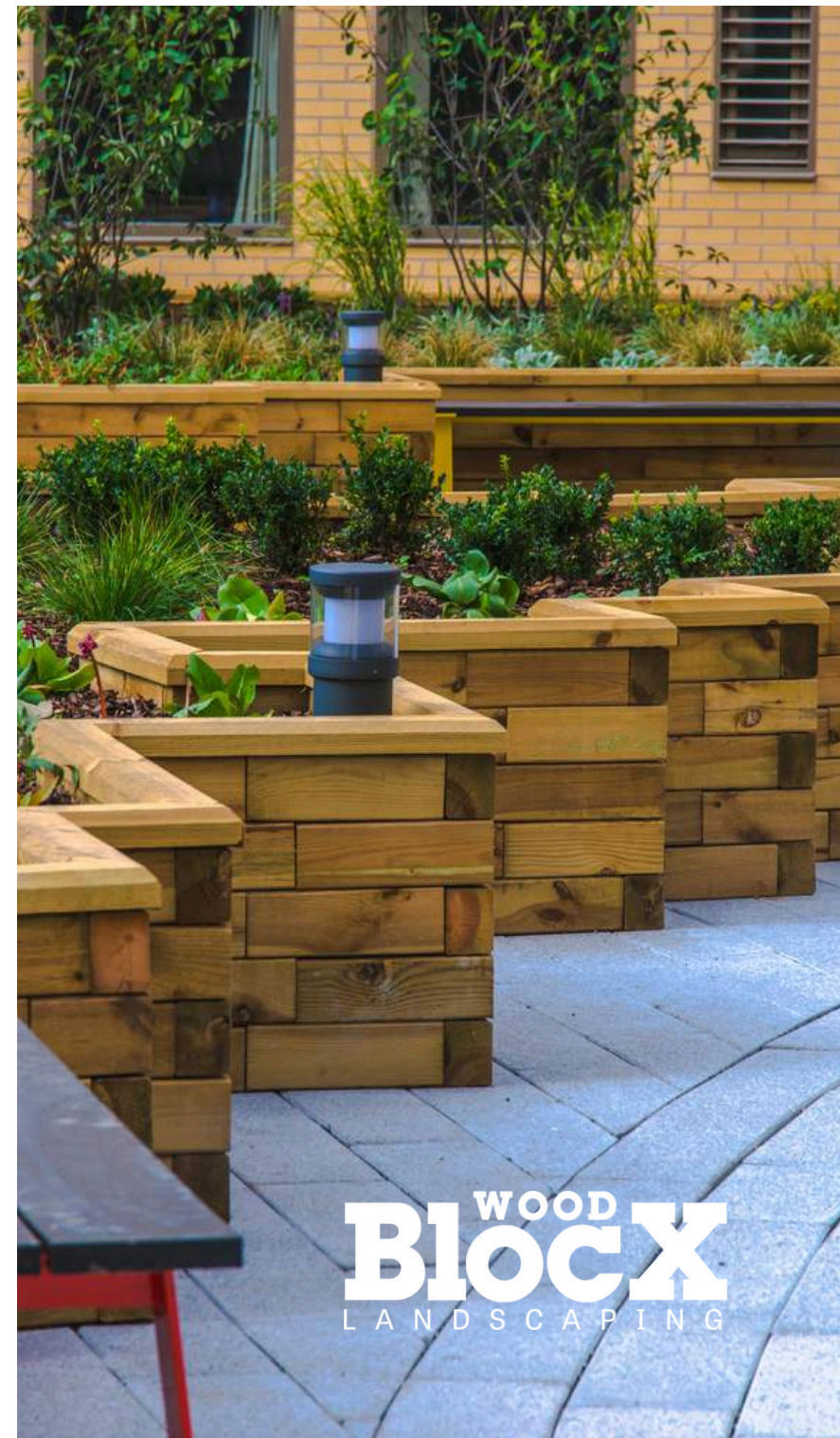

WOOD
BlocX
LANDSCAPING

Starting your build

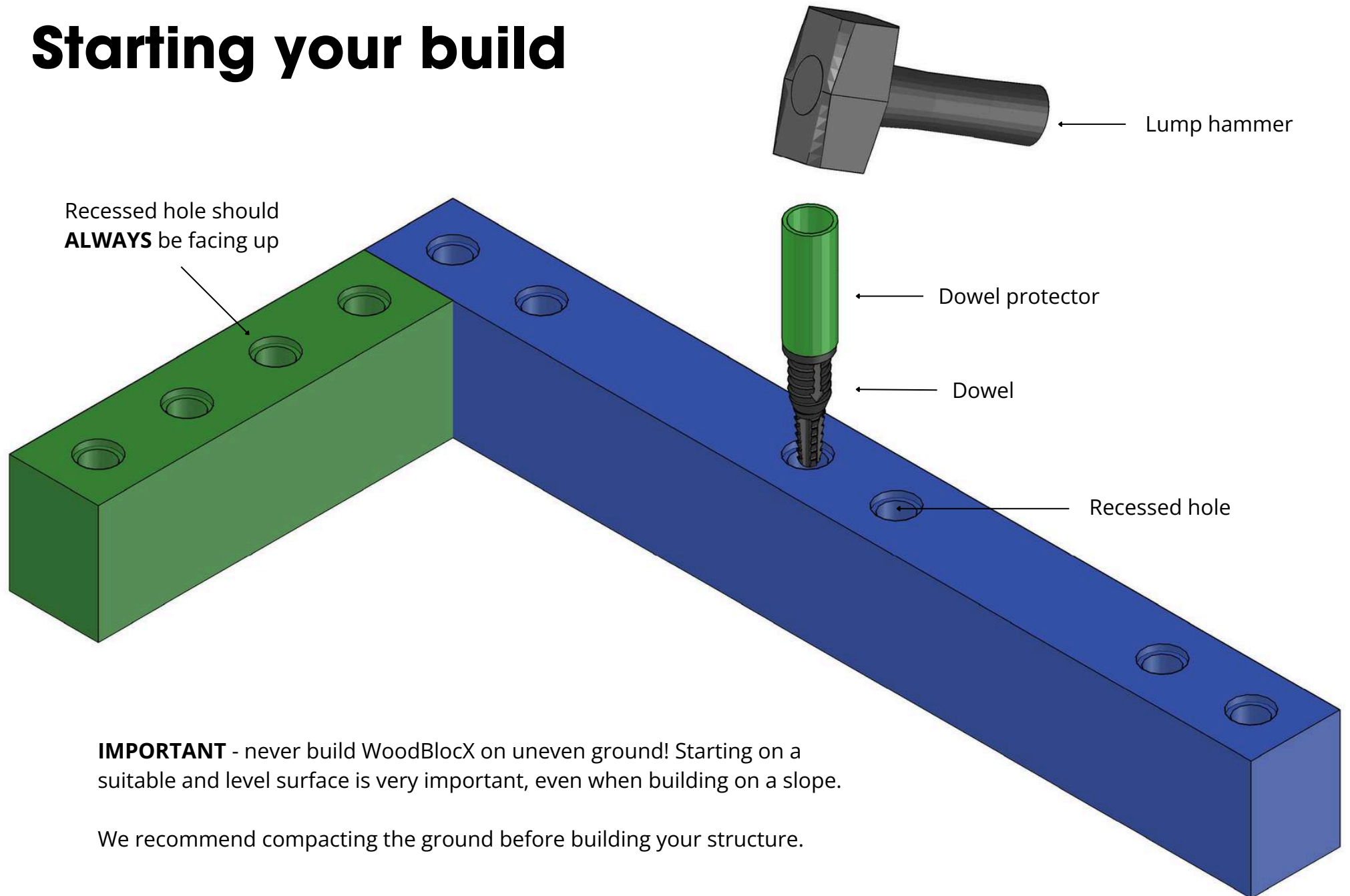

IMPORTANT - never build WoodBlocX on uneven ground! Starting on a suitable and level surface is very important, even when building on a slope.

We recommend compacting the ground before building your structure.

Levelling your build

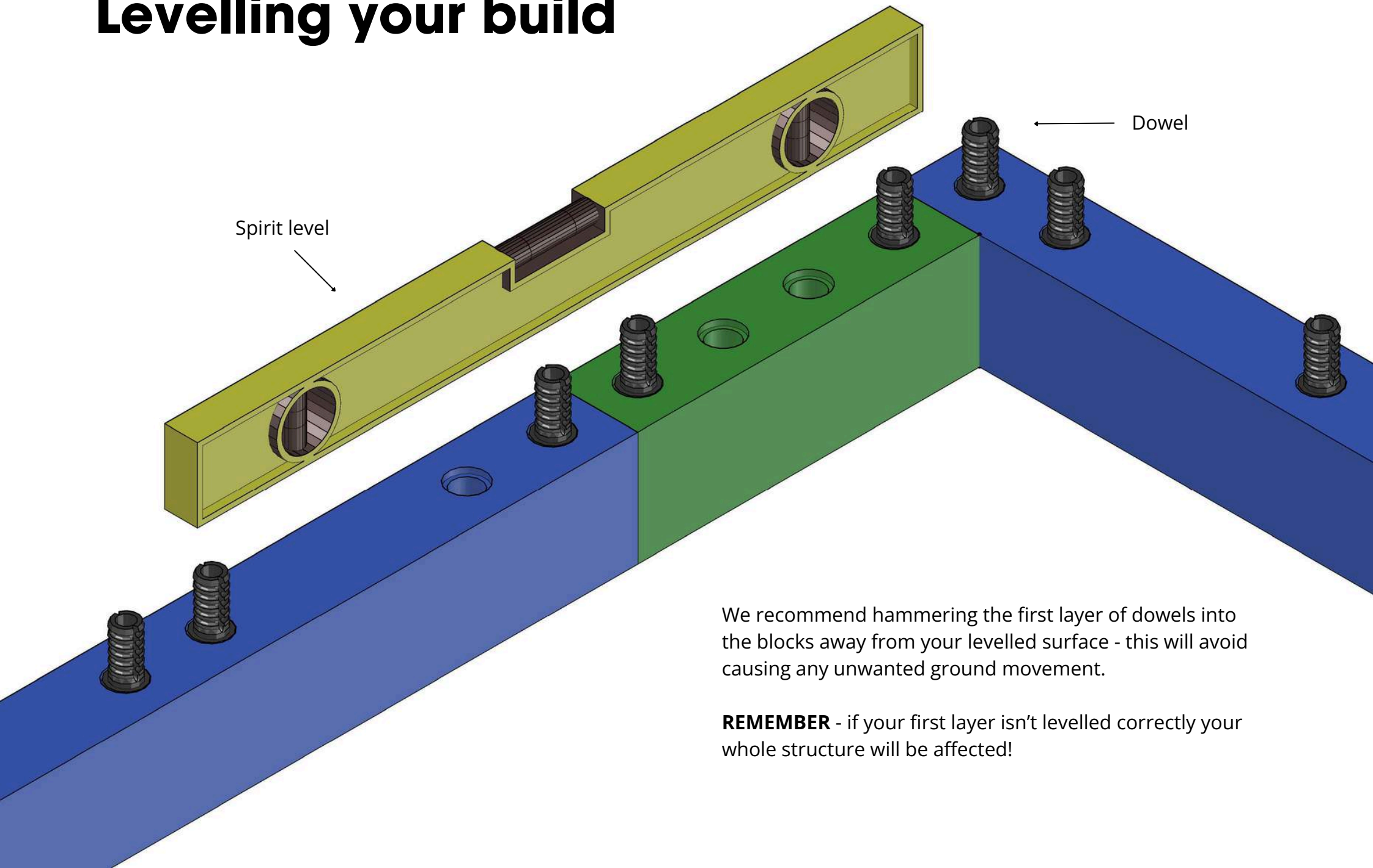

We recommend hammering the first layer of dowels into the blocks away from your levelled surface - this will avoid causing any unwanted ground movement.

REMEMBER - if your first layer isn't levelled correctly your whole structure will be affected!

Building on soft ground

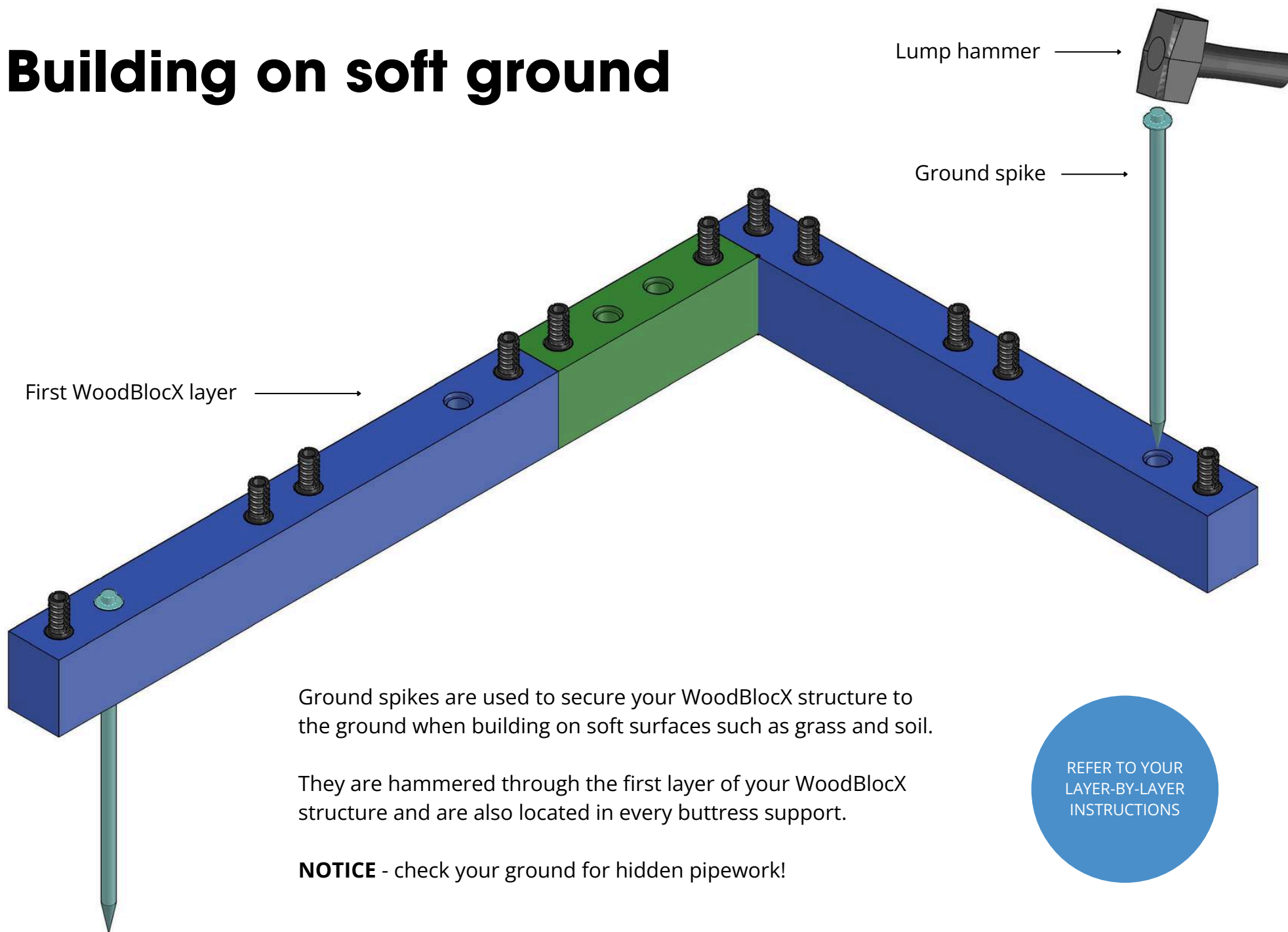

Ground spikes are used to secure your WoodBlocX structure to the ground when building on soft surfaces such as grass and soil.

They are hammered through the first layer of your WoodBlocX structure and are also located in every buttress support.

NOTICE - check your ground for hidden pipework!

REFER TO YOUR
LAYER-BY-LAYER
INSTRUCTIONS

Soft ground - technical detail

STANDARD DETAIL D-012

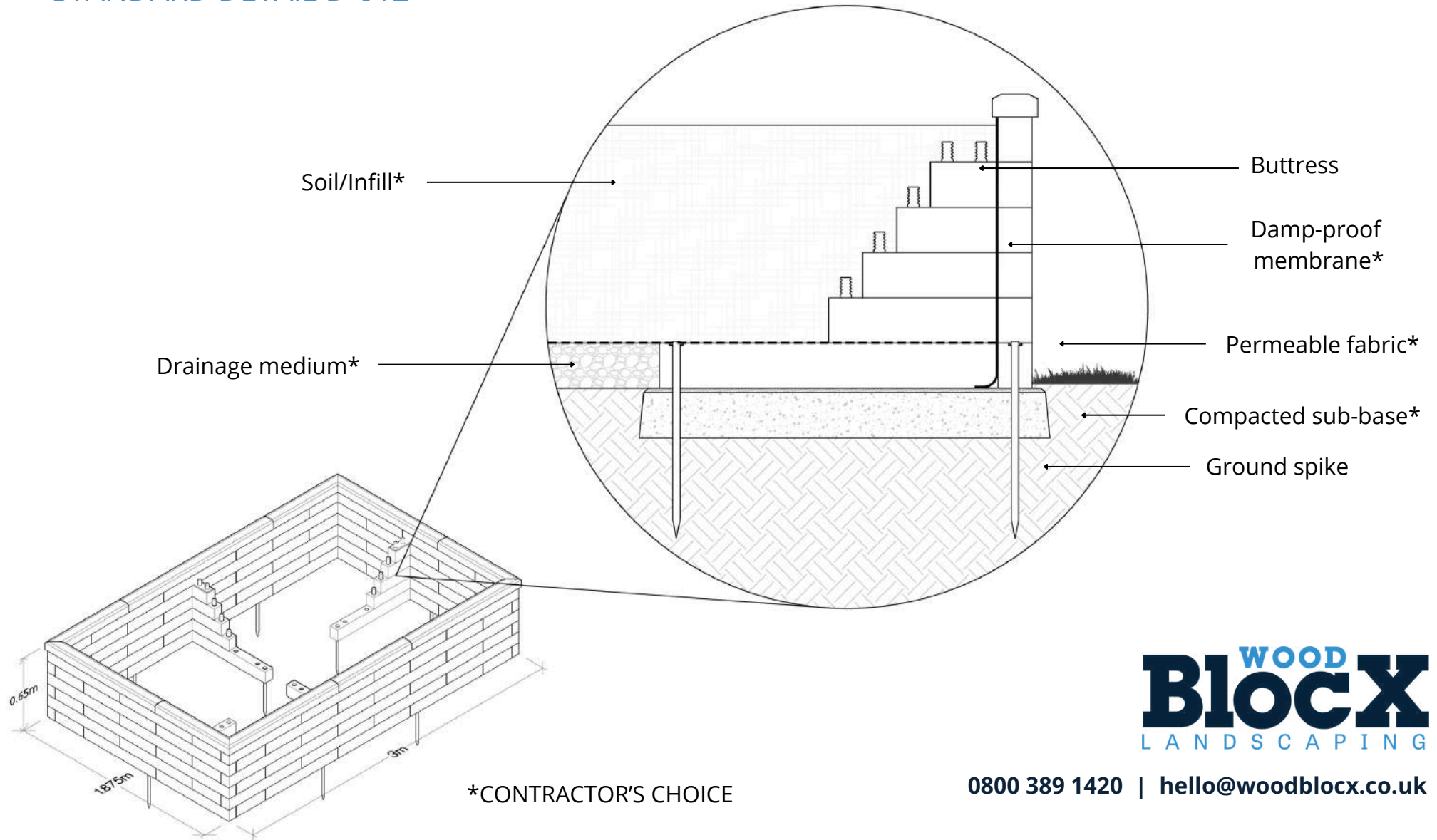

0800 389 1420 | hello@woodbloccx.co.uk

Building on hard ground

REFER TO YOUR
LAYER-BY-LAYER
INSTRUCTIONS

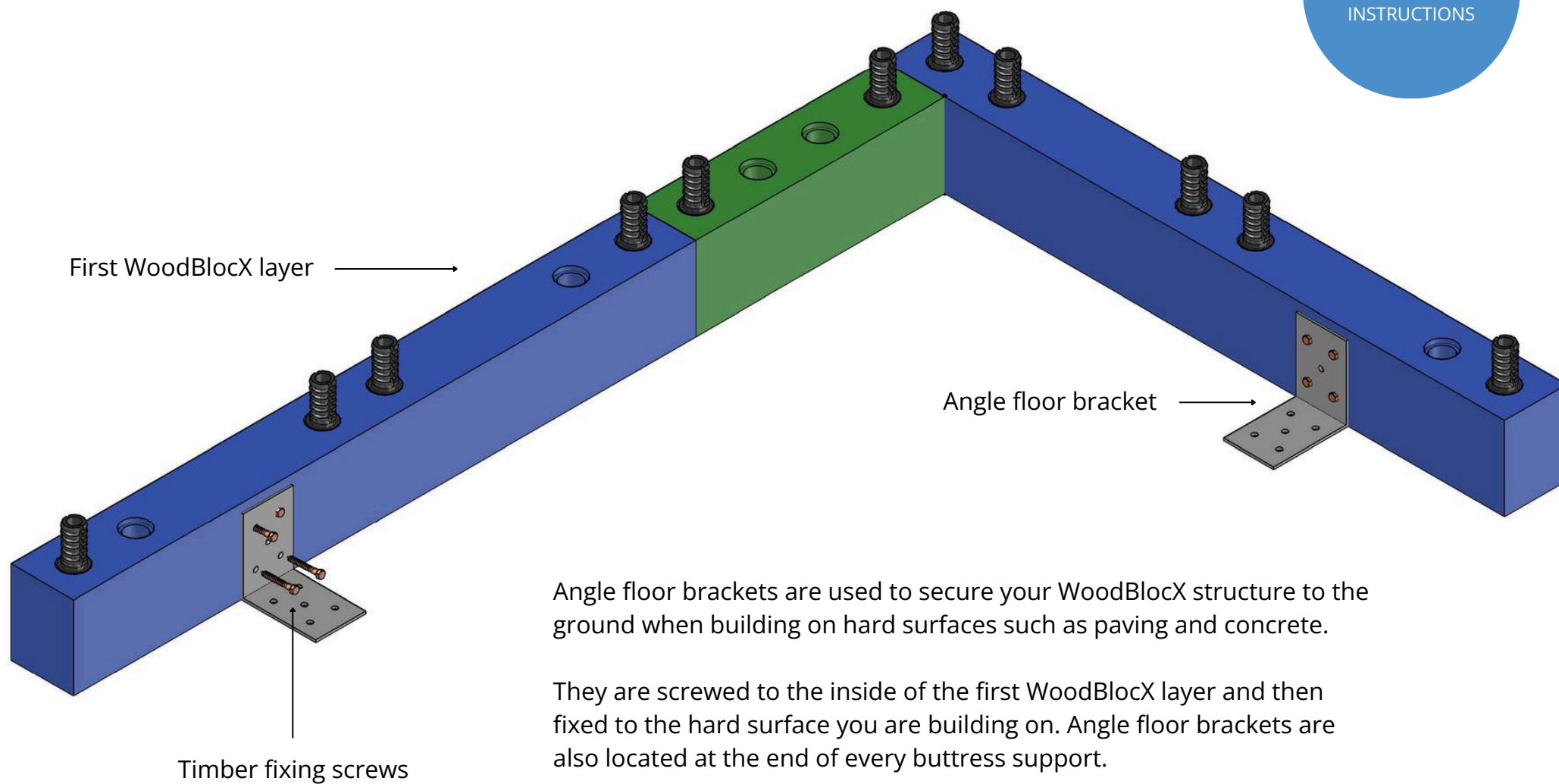

Angle floor brackets are used to secure your WoodBlocX structure to the ground when building on hard surfaces such as paving and concrete.

They are screwed to the inside of the first WoodBlocX layer and then fixed to the hard surface you are building on. Angle floor brackets are also located at the end of every buttress support.

NOTICE - you will need to source suitable fixings to securely attach the brackets to your hard ground type.

Hard ground - technical detail

STANDARD DETAIL D-013

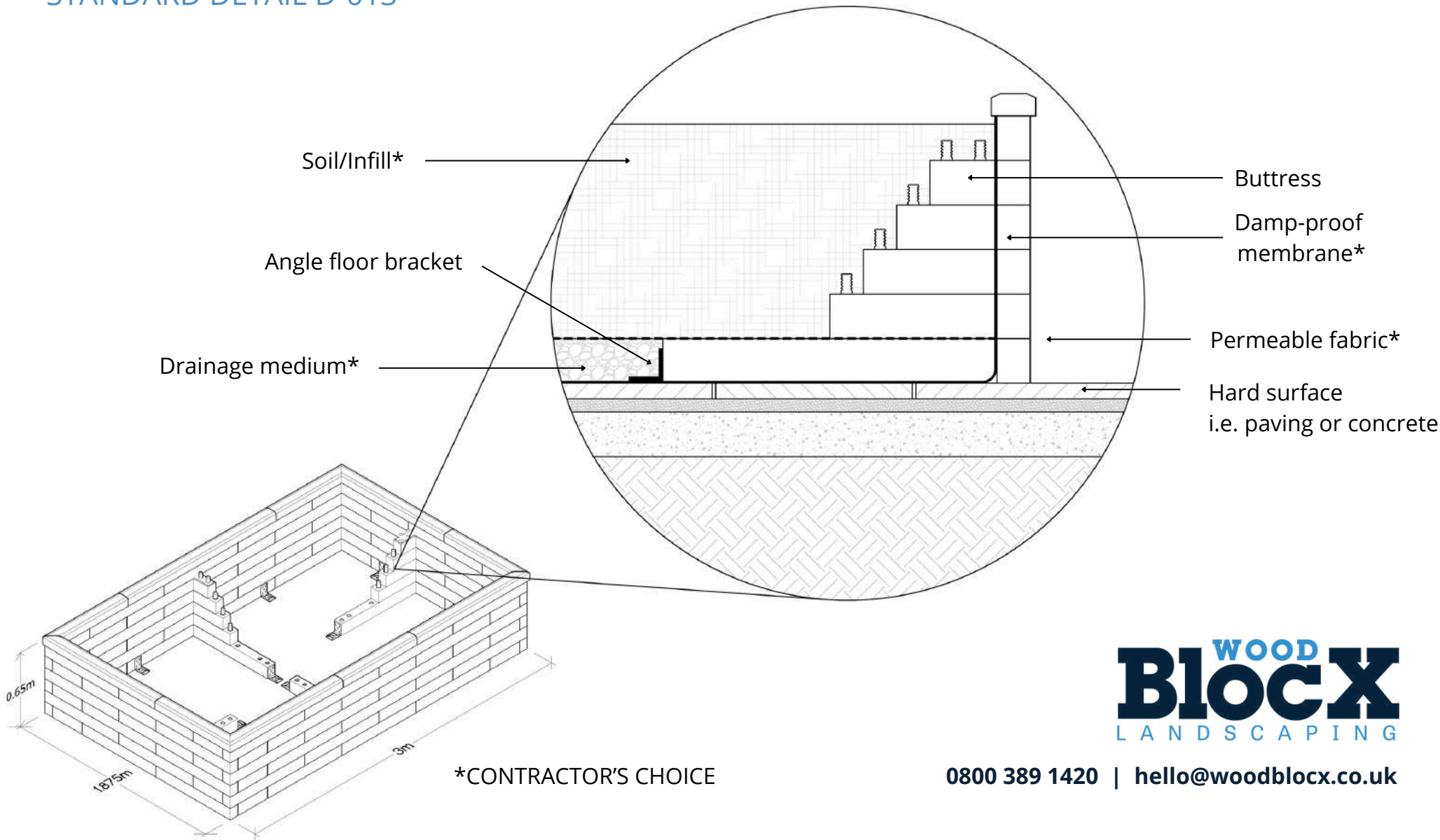

*CONTRACTOR'S CHOICE



0800 389 1420 | hello@woodblocx.co.uk

Connecting each layer together

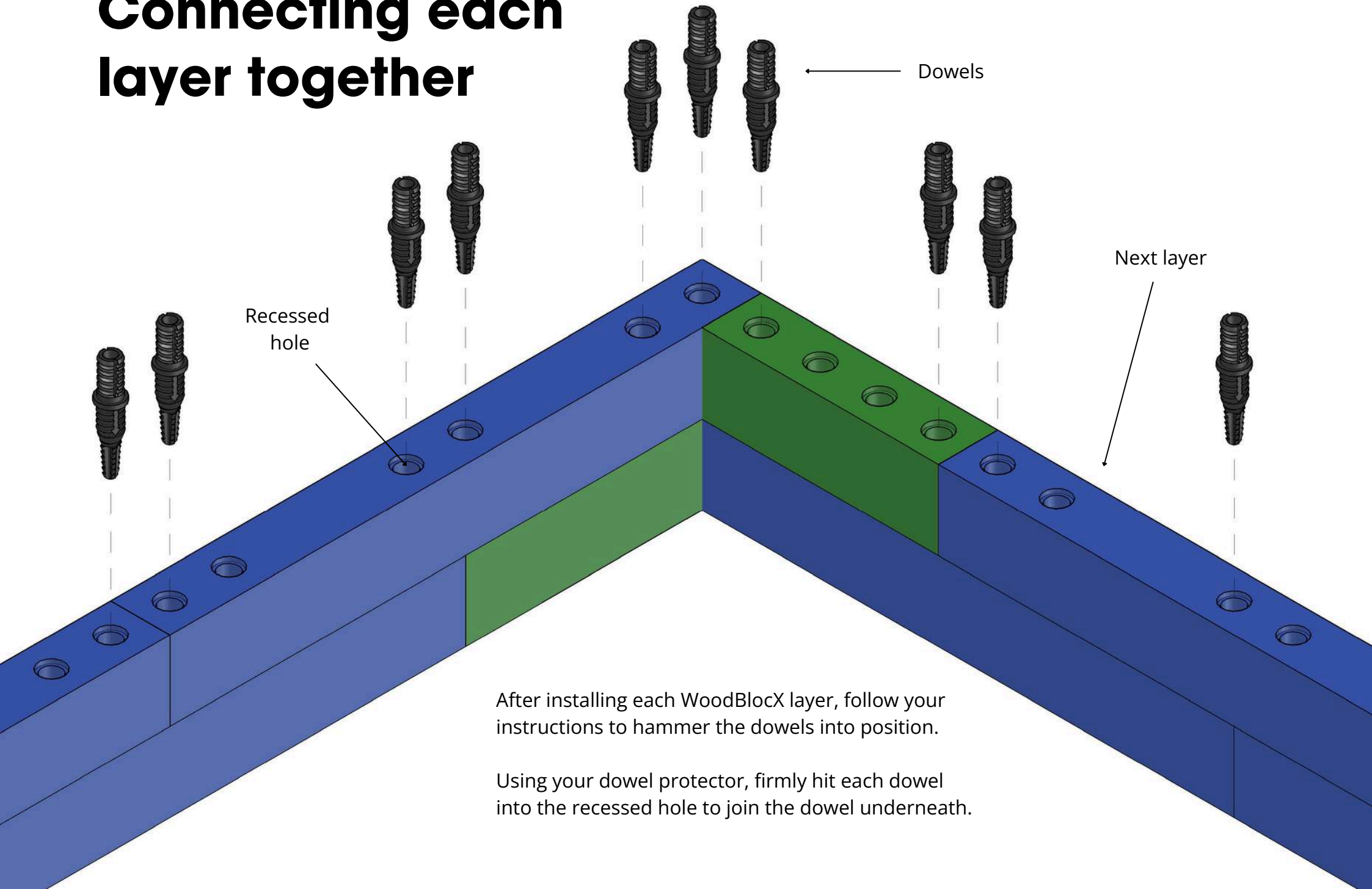

Recessed hole

Dowels

Next layer

After installing each WoodBlocX layer, follow your instructions to hammer the dowels into position.

Using your dowel protector, firmly hit each dowel into the recessed hole to join the dowel underneath.

Using the dowel removal tool

If you accidentally hammer a dowel into the wrong hole, it can be easily removed using the dowel removal tool.

Simply insert the tool into the top of the dowel, locating the groove on the inside, and **turn anticlockwise**.

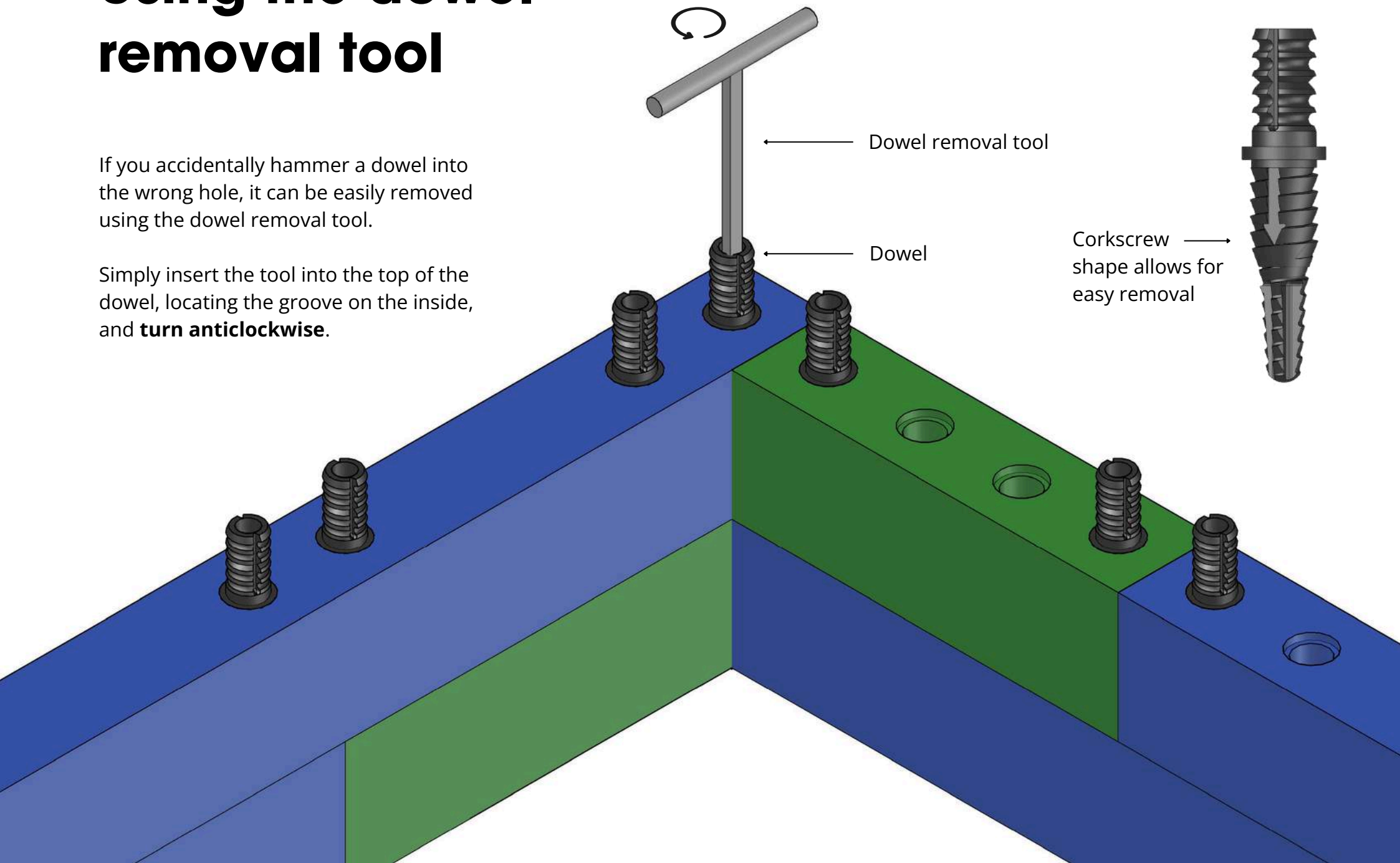

Installing a liner - best practice

SUBJECT TO CONTRACTOR'S CHOICE OF LINER

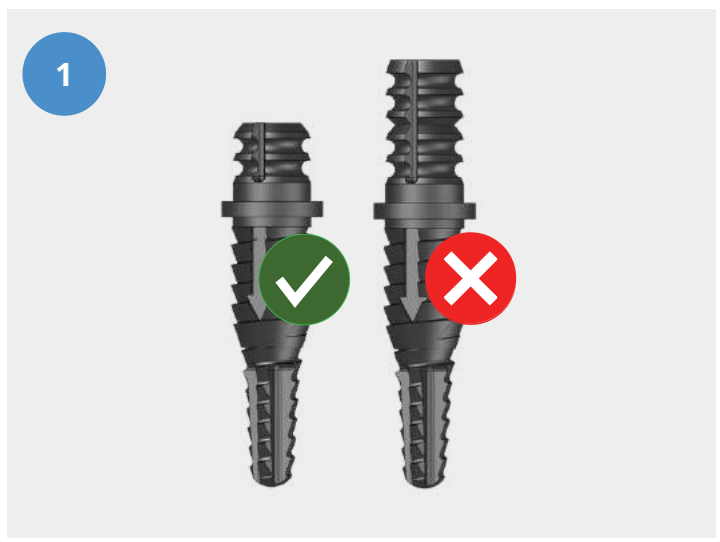

1

Final layer dowels (pre-cut) - before adding liner or the finishing capping layer, get your dowels ready!



2

COVER ALL SUPPORTING BUTTRESSES WITH LINER

Get your liner into position - make small incisions for the final layer dowels to push through the liner.



3

Trap your liner with dowels - hammer through your final layer dowels to secure the liner to the structure.



4

Trim excess liner with a sharp knife - using a retractable blade carefully cut away overhanging liner.



5

PAGE 14 - GENERAL BUILDING GUIDE

Install your angle corner plates - use your dowel protector to hammer these plates firmly into place.



6

Knock on your capping layer - use a spare BlocX to protect the wood when hammering. **JOB DONE!**

Final layer dowels

Before adding capping...

WoodBlocX designs now use our **NEW** final layer dowels. These are pre-cut to fit correctly under your capping layer.

Using your dowel protector, hammer the final layer dowels into place - you are then ready to install your capping layer.

FINAL LAYER DOWELS ARE PRE-CUT TO SIZE
DO NOT CUT!

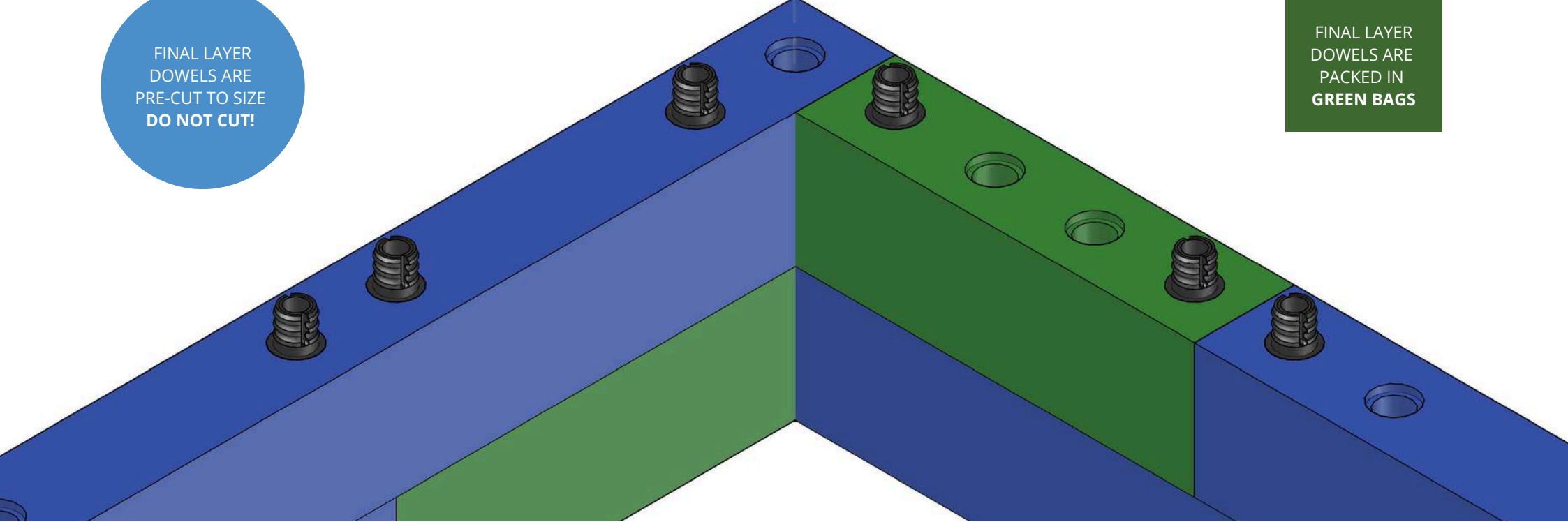
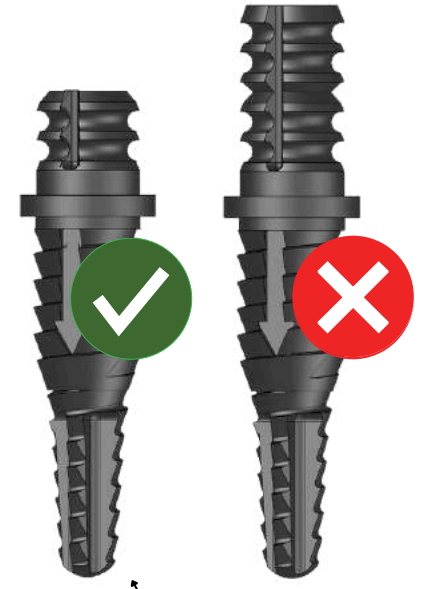
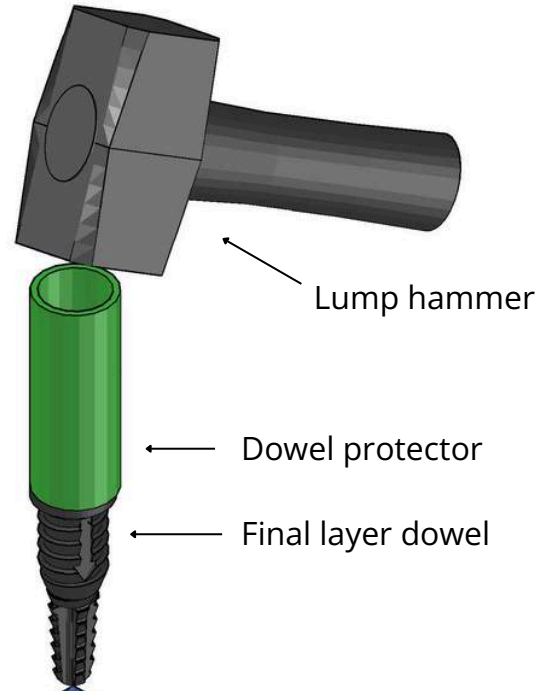

Installing angle corner plates

Angle corner plates are installed on the final WoodBlocX layer before you add the capping. Using your dowel protector, hammer them into place **over the top** of the final layer dowels.

Refer to your design's layer-by-layer instructions as your structure may include extras.

NOTE - Buttresses are designed with angle corner plates at every level - see [Page 16](#).

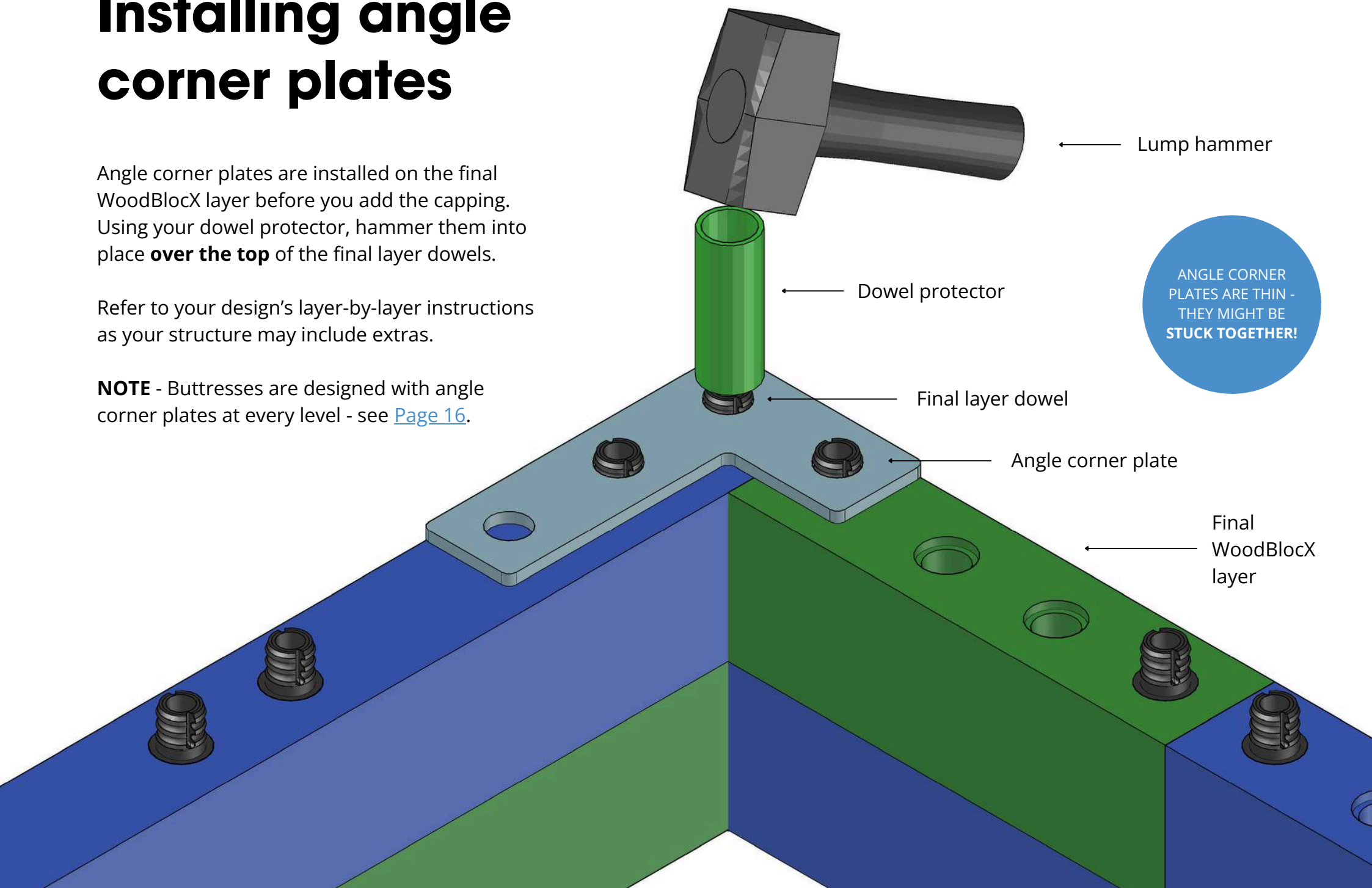

ANGLE CORNER PLATES ARE THIN - THEY MIGHT BE STUCK TOGETHER!

Adding the capping layer

Use a spare BlocX to prevent damage when hammering the capping layer into place.

Start at one corner and work your way around until it is all firmly in place.
It should sit tight against the layer below - force may be needed!

TRADITIONAL & MODERN CAPPING STYLES ARE FITTED THE SAME WAY

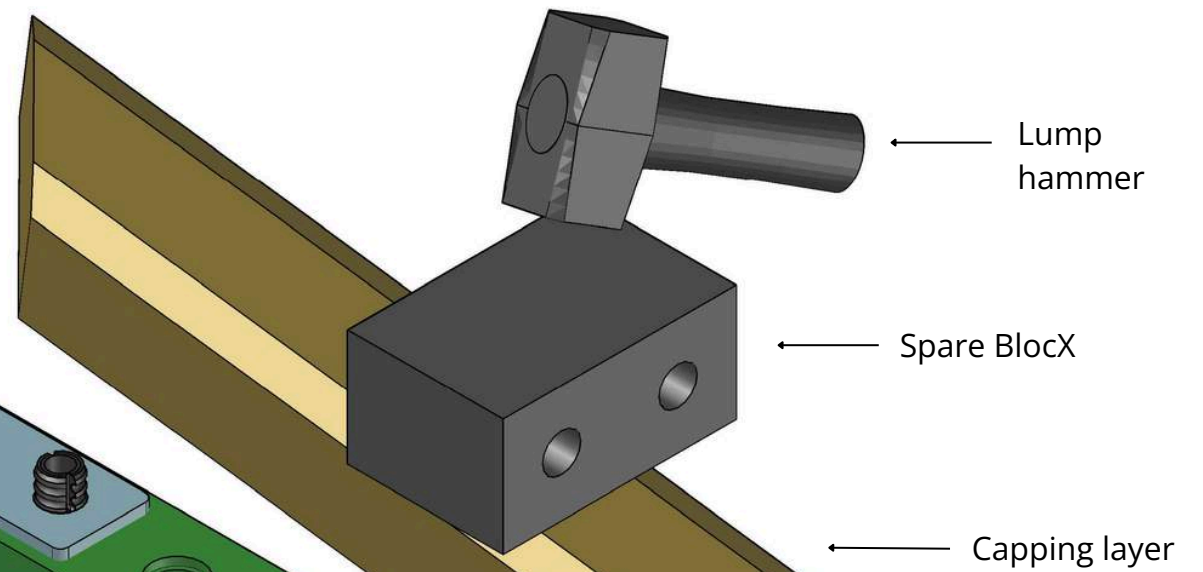

Capping can be identified by the number of holes on the underside.

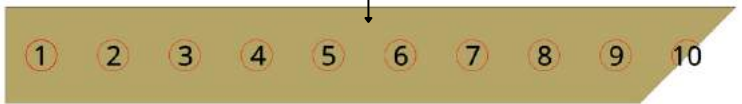

If your design includes buttresses

WoodBlocX buttress supports act as cantilevers under the weight of soil, keeping the main structure supported and strong.

Buttresses will always **finish one layer below** the main height of the structure. They are normally only required in structures larger than 2 metres in length and above 25cm in height.

In some instances, WoodBlocX designs will have a complete brace support spanning the width of the structure, rather than freestanding buttresses.

REFER TO YOUR LAYER-BY-LAYER INSTRUCTIONS

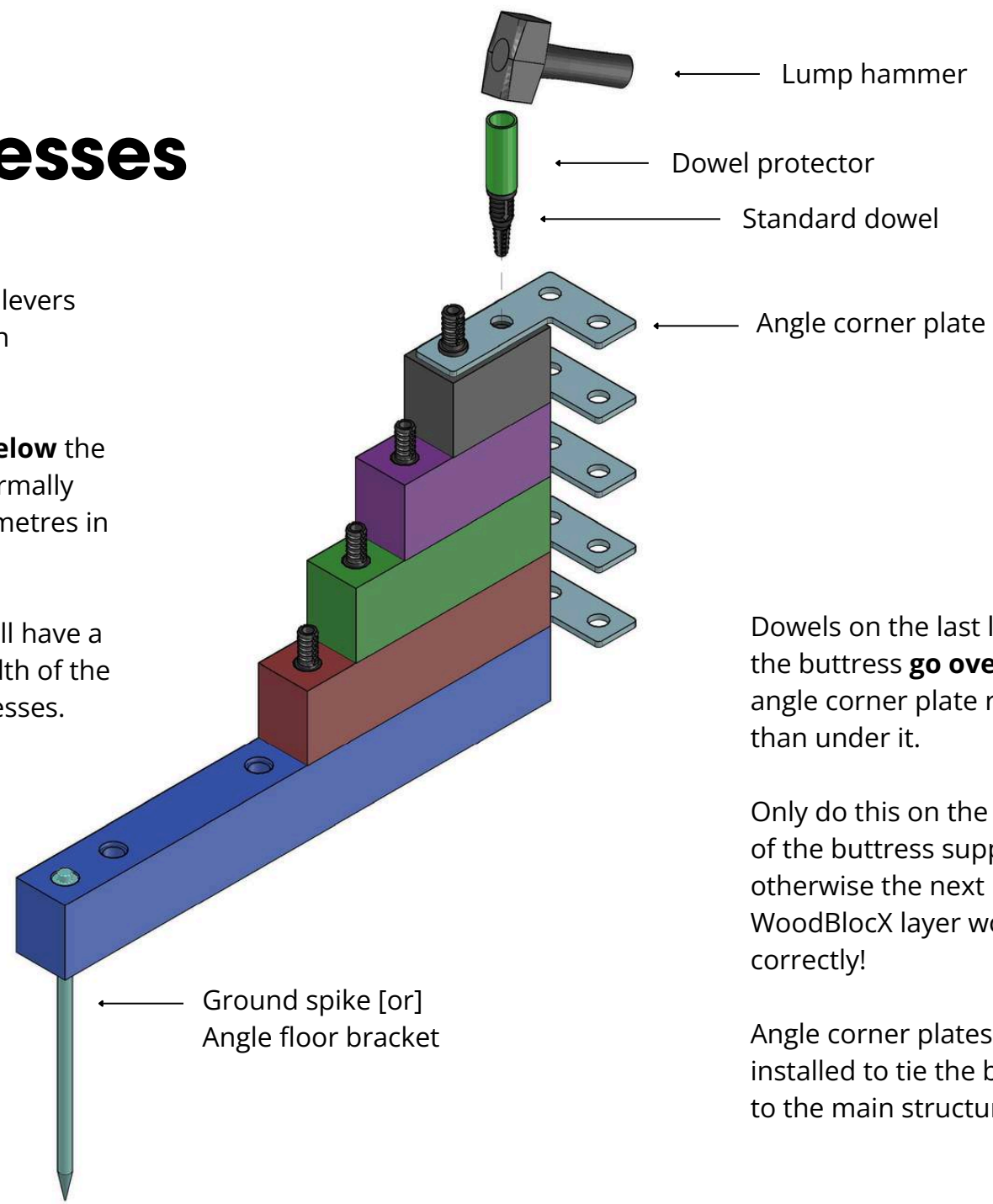

Dowels on the last level of the buttress **go over** the angle corner plate rather than under it.

Only do this on the top layer of the buttress support otherwise the next WoodBlocX layer won't fit correctly!

Angle corner plates must be installed to tie the buttress to the main structure.

If your design includes curves

Curved WoodBlocX sections are created from specially cut blocks which are countersunk on both sides.

Each curved joint creates a 15° angle. These angles are achieved using a combination of our curved WoodBlocX.

Due to their size, levelling these WoodBlocX can be difficult. We suggest you build them in sections on a firm level surface and then position them into place once built.

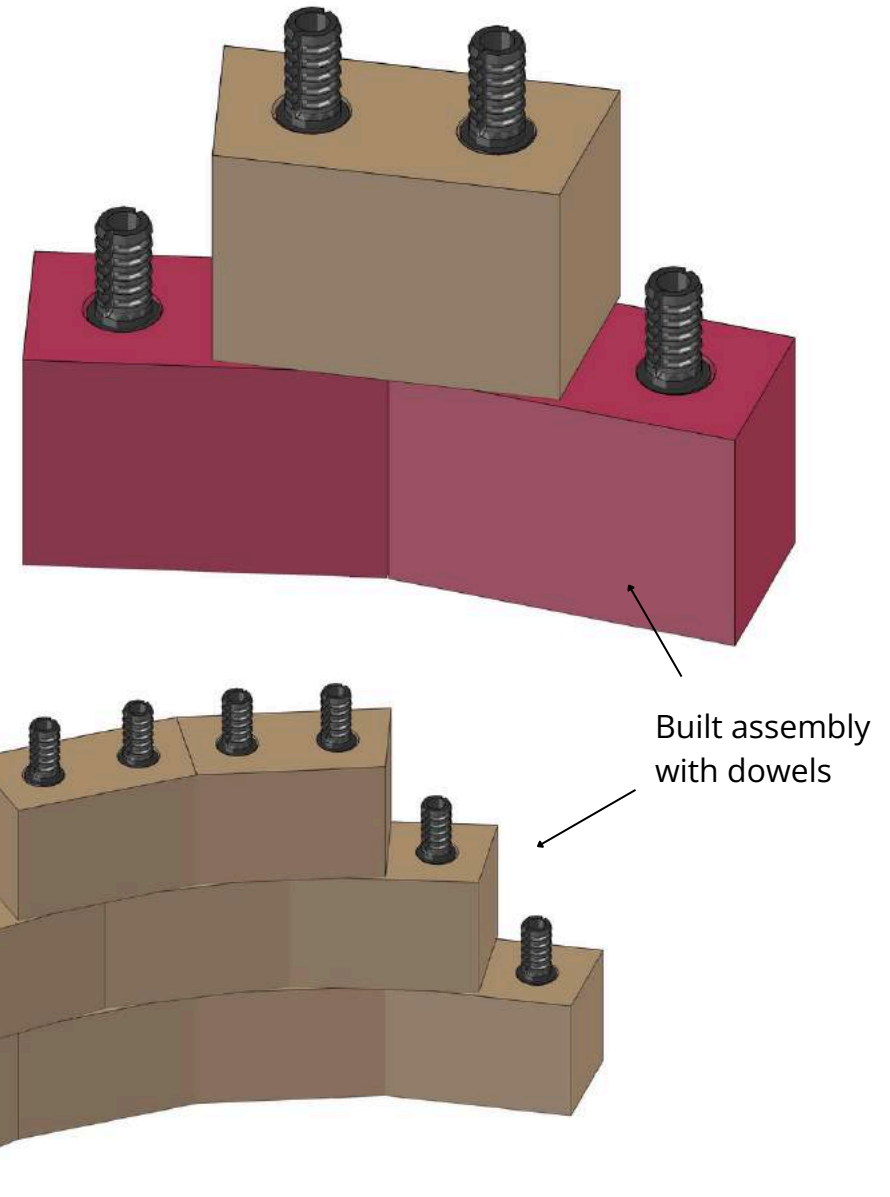
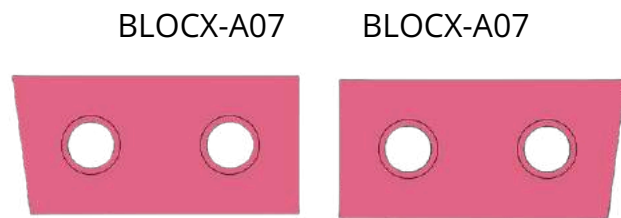
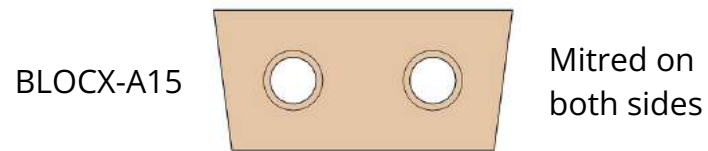

If your design includes 45° BlocX

45° angled WoodBlocX sections are created from specially cut WoodBlocX which are countersunk on both sides.

There are two types of 45° BlocX - long and short. These WoodBlocX combine as shown below to create obtuse 135° angles in our structures.

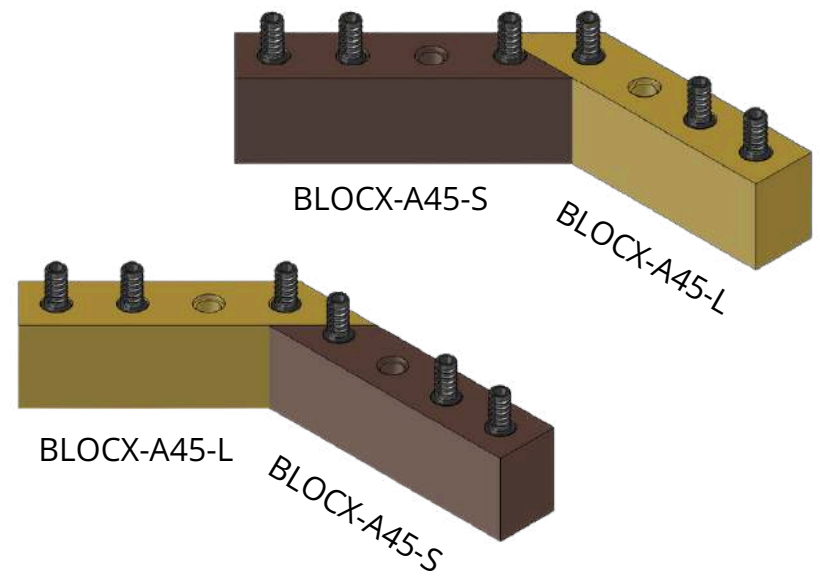
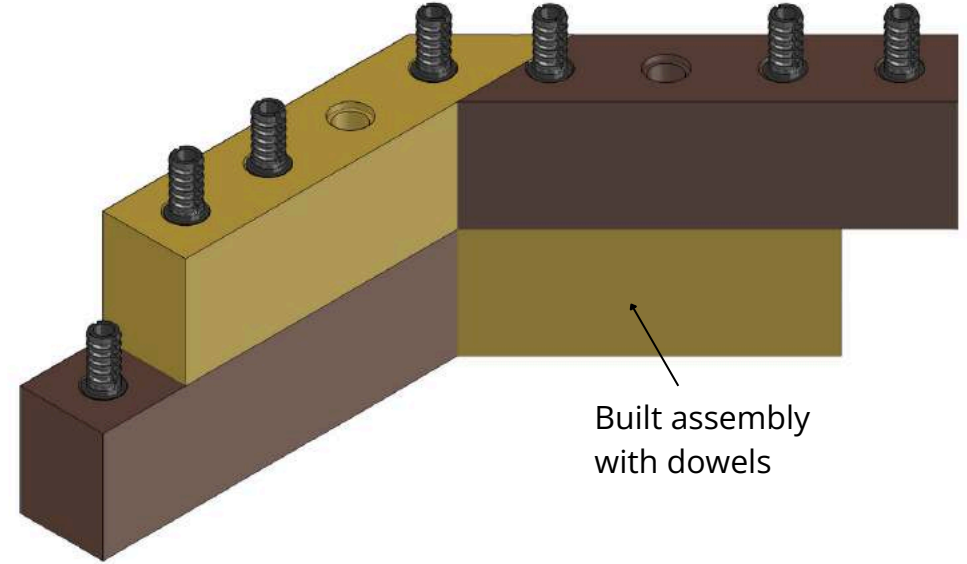
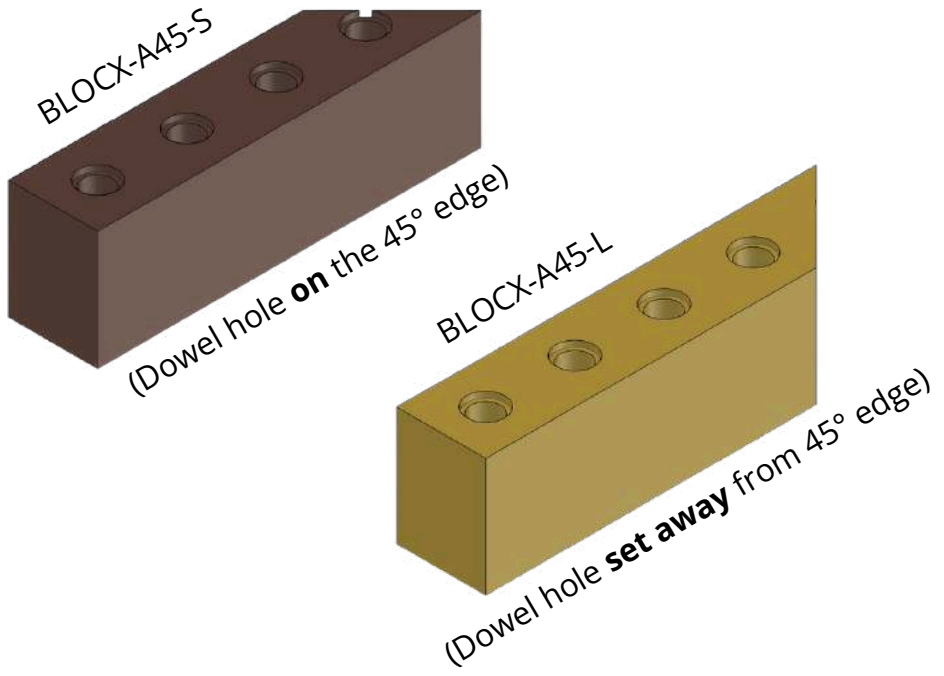

Building seating

If your WoodBlocX design includes seating, all the extra components you need to build the seating area will be included in your kit.

WoodBlocX seating areas are created from specially cut seat top capping which is pre-drilled only on the underside.

To install, simply hammer the seat top capping into place. Use a spare BlocX to prevent damage when hammering down.

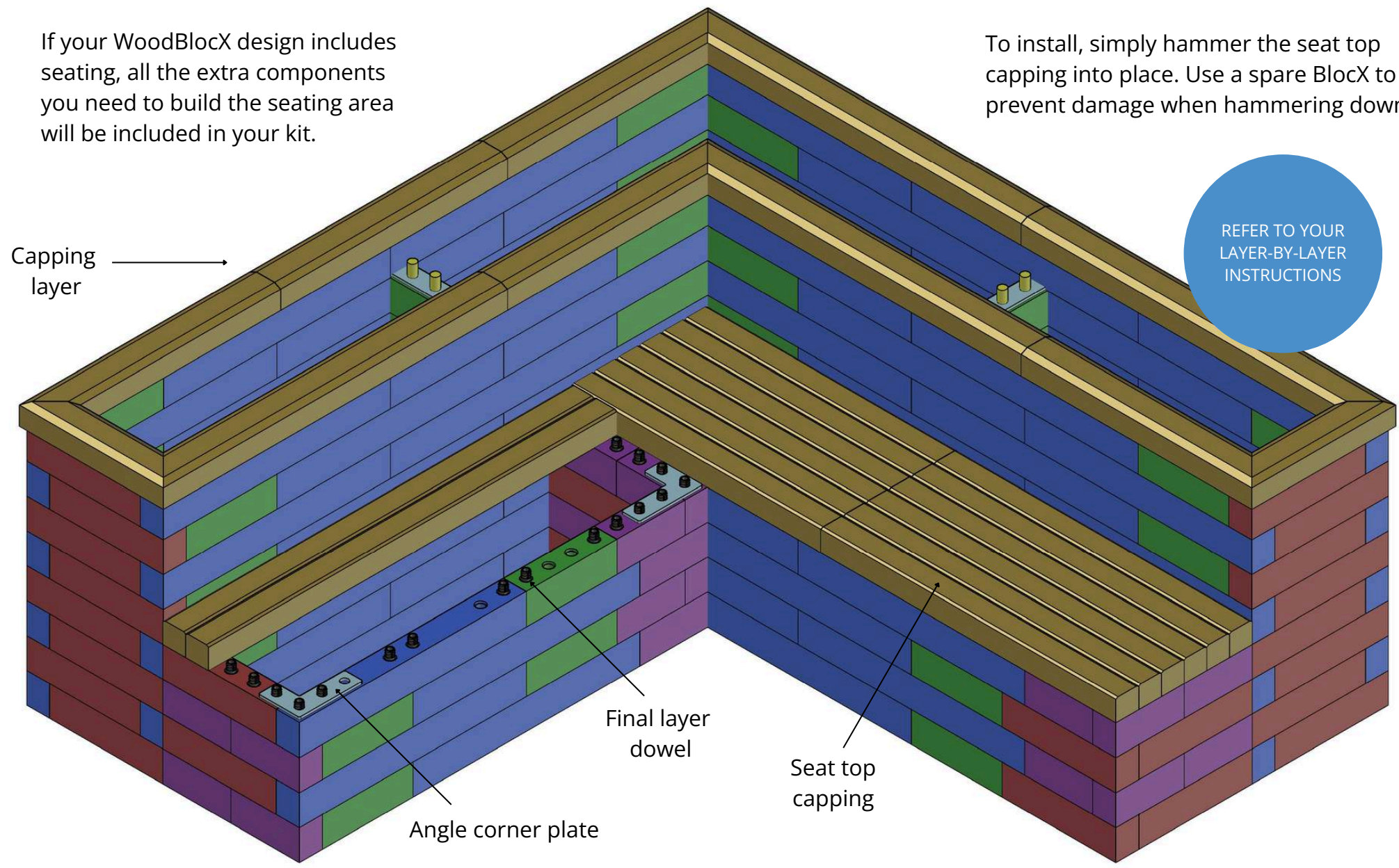

Capping layer

REFER TO YOUR LAYER-BY-LAYER INSTRUCTIONS

Final layer dowel

Seat top capping

Angle corner plate

Building retaining walls

If your WoodBlocX design includes retaining walls, it will be important to make sure the backfill is free draining to avoid water build up.

WoodBlocX buttresses are essential for providing retention strength. Please ensure you have read [Page 16](#) - *If your design includes buttresses.*

REFER TO YOUR LAYER-BY-LAYER INSTRUCTIONS

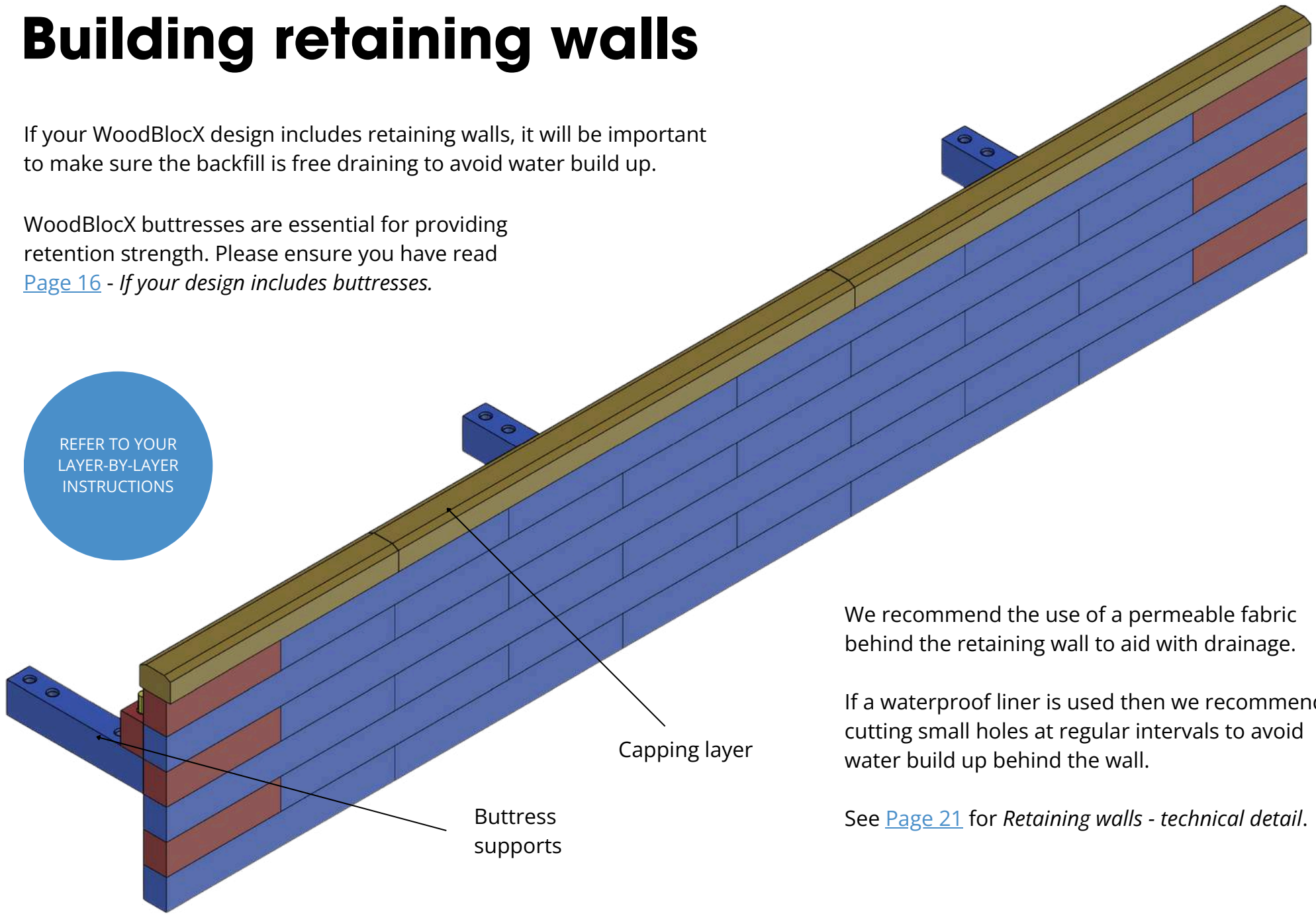

We recommend the use of a permeable fabric behind the retaining wall to aid with drainage.

If a waterproof liner is used then we recommend cutting small holes at regular intervals to avoid water build up behind the wall.

See [Page 21](#) for *Retaining walls - technical detail.*

Retaining walls - technical detail

STANDARD DETAIL D-011

Backfill by hand **ONLY**.

Allow for adequate drainage to maximise lifespan.

*CONTRACTOR'S CHOICE

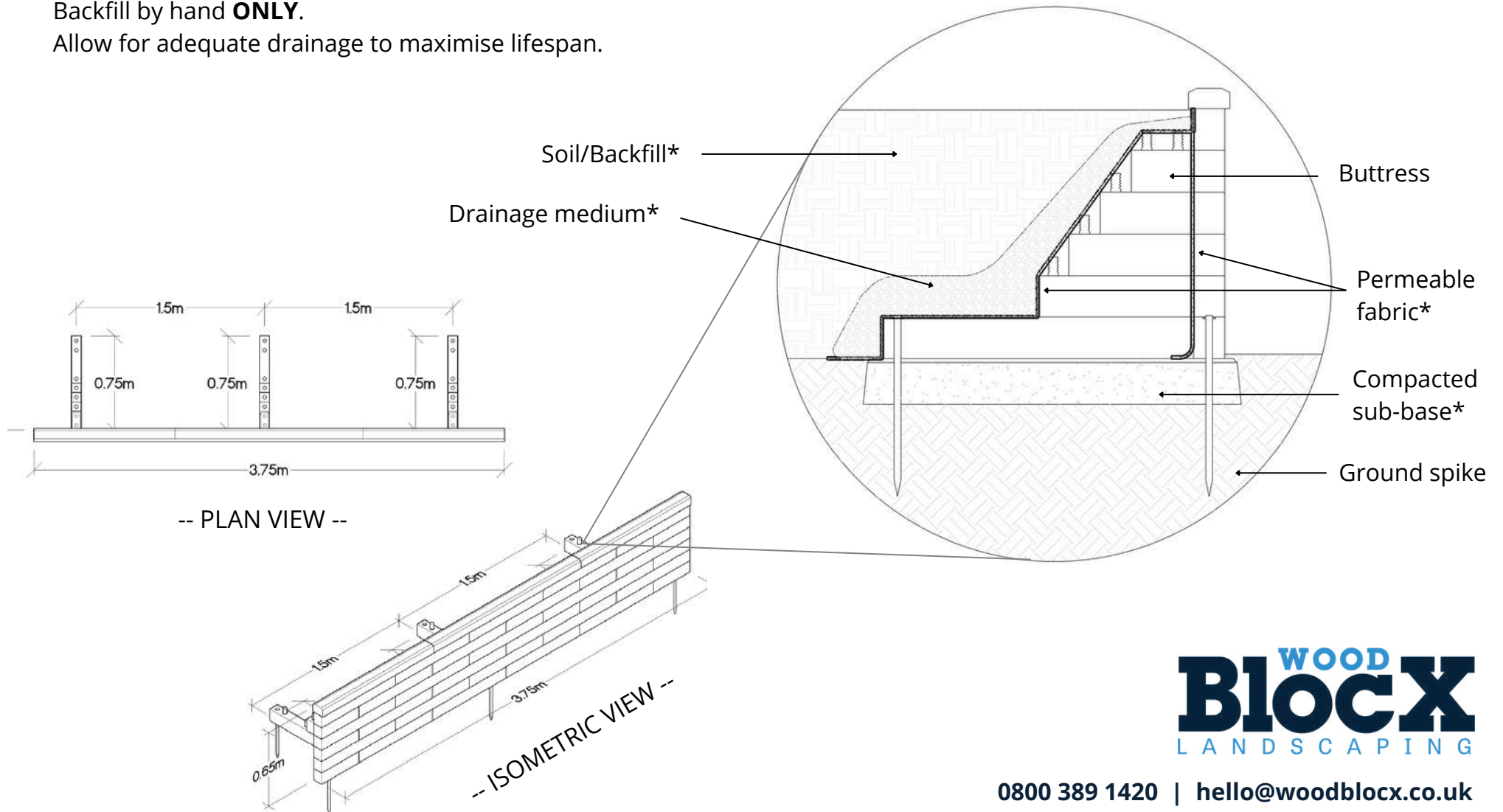

WOOD
BlocX
LANDSCAPING

0800 389 1420 | hello@woodblocx.co.uk

Building steps

If your WoodBlocX design includes steps, all the extra components you need to build the steps will be included in your kit.

Our steps are designed to be cut into a bank of earth and are not a solid unit built to the floor.

WoodBlocX steps are created from specially cut step tread capping which is pre-drilled only on the underside.

To install, simply hammer the step tread capping into place. Use a spare BlocX to prevent damage when hammering down.

REFER TO YOUR LAYER-BY-LAYER INSTRUCTIONS

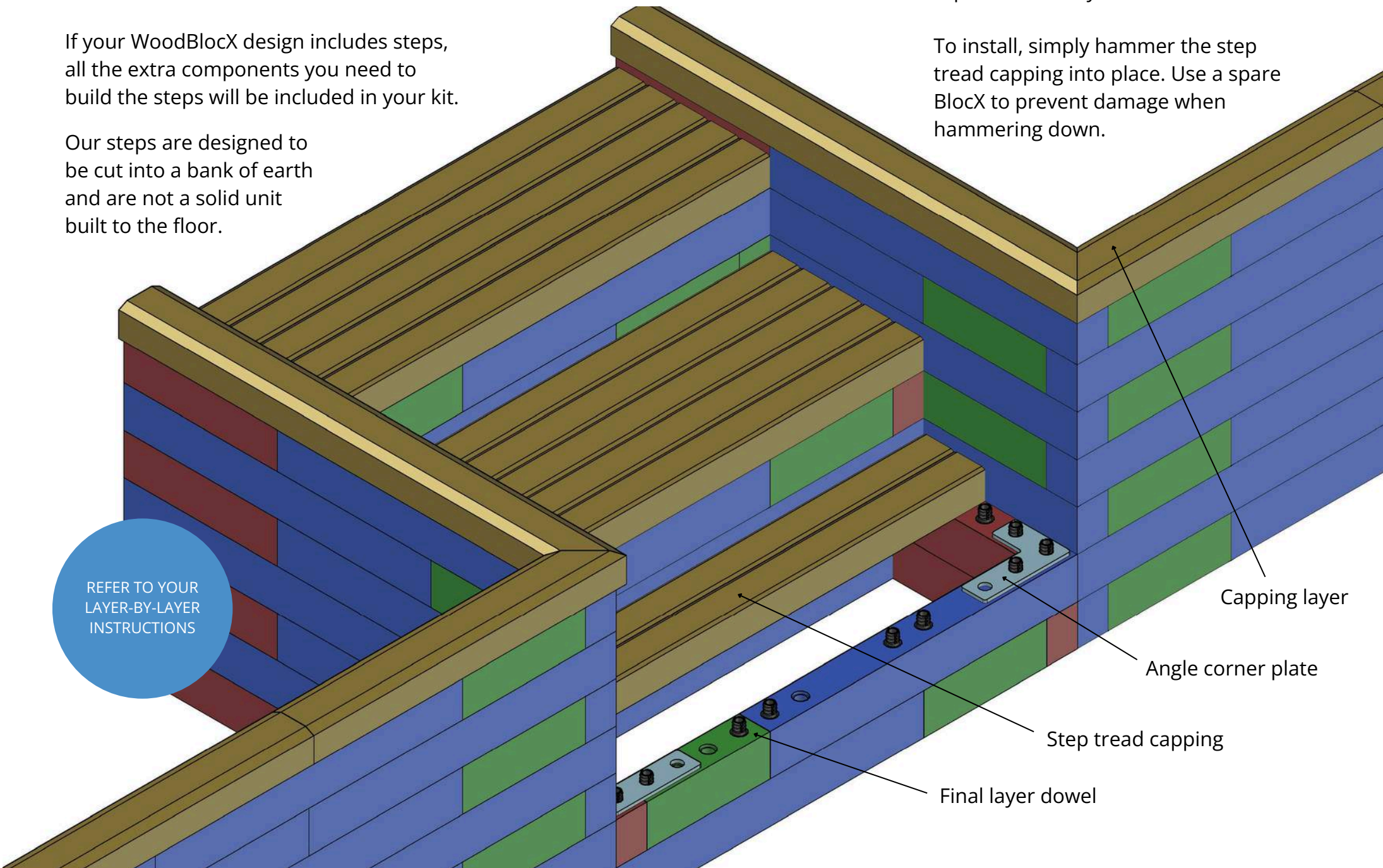

Capping layer

Angle corner plate

Step tread capping

Final layer dowel

WoodBlocX colour code



BLOCX-10 (L 750 x W 75 x H 100 mm)

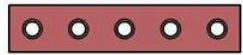

BLOCX-05 (L 375 x W 75 x H 100 mm)



BLOCX-04 (L 300 x W 75 x H 100 mm)



BLOCX-03 (L 225 x W 75 x H 100 mm)



BLOCX-02 (L 150 x W 75 x H 100 mm)



BLOCX-A15 (L 160 x W 75 x H 100 mm)



BLOCX-A07 (L 155 x W 75 x H 100 mm)



BLOCX-A45-L (L 353 x W 75 x H 100 mm)



BLOCX-A45-S (L 322 x W 75 x H 100 mm)



Standard dowel



Final layer dowel



Angle corner plate



Ground spike



Angle floor bracket



PROJECT-SPECIFIC
INSTRUCTIONS
INCLUDED WITH
YOUR DELIVERY

WOOD
BlocX
LANDSCAPING

0800 389 1420 | hello@woodblocx.co.uk