



PERIMETER
SECURITY
MANUFACTURER

PRODUCT TITLE:

Network Rail Class 1A Combi™ Palisade

PRODUCT DATA SHEET



WHY CHOOSE NETWORK RAIL COMBI™ PALISADE MANUFACTURED BY LOCHRIN BAIN

- Approved manufacturer to Network Rail for over 30 years.
- Manufactured in the UK using British Steel.
- Secured By Design product which is a Police preferred specification.
- The most cost-effective Class 1A solution on the market.
- LPS1175 certification to A1 (SR1) available on request.
- Patented Vee slot design for added security.
- Unique counter bored bolt to pale fixing fittings for added security.
- Manufactured to minimum BS1722-12:2016.
- Drawings can be supplied in both CAD and BIM format.
- 40 year design life guarantee.
- Combi™ is supplied in kit-form for ease of transportation, Handling and installation.
- Designed to rake to suit uneven or sloping ground conditions.
- Full range of Pedestrian and Vehicle gates available.
- Cantilever, Tracked and Bi-folding gates available.
- Available in a choice of RAL colours.



COMMERCIAL



UTILITY



PUBLIC AREAS



RAIL



#WESECUREWHATYOUNEEDTOPROTECT

WWW.LOCHRIN-BAIN.CO.UK SALES@LOCHRIN-BAIN.CO.UK +44 (0)1236 457333





PERIMETER
SECURITY
MANUFACTURER

PRODUCT TITLE:

Network Rail Class 1A Combi™ Palisade

PRODUCT DATA SHEET

Product Technical Information

Standards:	Manufacturing: BS1722-12:2016. Galvanizing: BS EN ISO 1461:2009. Powder Coating: BS EN 13438:2013.
Panel Height:	1.8m / 2.4m / 3.0m high – bespoke heights available from 1.8m up to 4.5m.
Post Centres:	2.75m (+/-5mm) Bespoke widths available upon request.
Post:	1 No. 102x44x2525mm RSJ (1.8m) / 1 No. 102x44x3175mm RSJ (2.4m) / 1 No. 127x76x3925mm UB (3.0m).
Post to Rail Fixings:	30x8mm x 160mm Fishplate for connecting to rails using M12x30 Cup Square Bolts c/w M12 Shear Nuts.
Rails:	2 No. 45x45x6mm Vee slot RSA (1.8m) / 2 No. 45x45x6mm Vee slot RSA (2.4m) / 3 No. 50x50x6mm Vee slot RSA (3.0m).
Pales:	17 No. 'D' 3mm x 1750mm (1.8m) / 17 No. 'D' 3mm x 2350mm (2.4m) / 17 No. 'D' 3.0mm x 2950mm (3.0m).
Pale Heads:	Single Point or Rounded.
Pale Fixings:	M8x25 Cup Square Bolts c/w M8 Shear cone.
Finish:	Hot Dipped Galvanized as standard with an option to powder coat to various RAL colours including marine grade if required.
Anti-Climb Toppings:	Various options available on request including extensions for Barb, Barbed Tape, Razor Coil & Rotating Spikes.
Gates:	Pedestrian and Vehicle gates are manufactured in various widths to suit Network Rail Class 1A Palisade specification.
Enhancements:	Compatible with all EPID & MPID systems.
Foundations:	Foundation details vary depending on site location and ground conditions, refer to BS1722-12:2016 for guidance.
Warranty:	40 Year design life guarantee provided upon request.

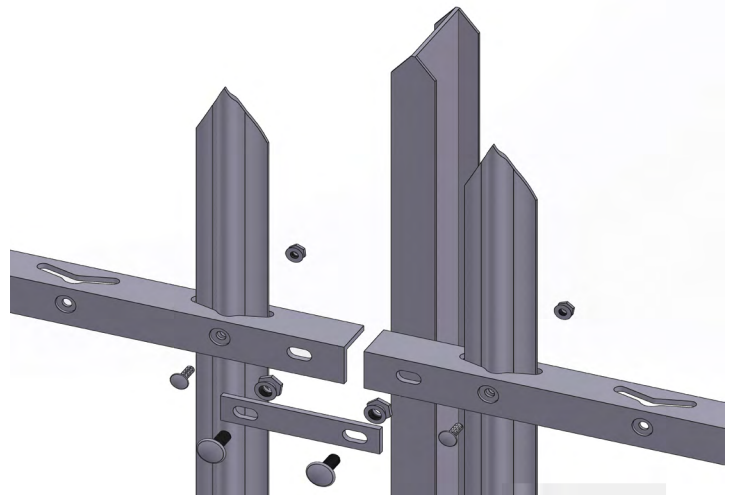

CLICK NOW

SCAN
QR CODE
TO FIND
OUT MORE

DISCLAIMER

Contractors shall employ experienced installers, providing qualified supervision to complete works as specified by the manufacturer and in accordance with BS1722-12:2016. Every care has been taken to ensure that the information provided in this document is accurate at date of print. Lochrin Bain Ltd reserve the right to change product specification at any time. Contractors must ensure exact dimensions and specification is confirmed prior to ordering of material and installation.

Document Ref: DS/NRCLASS1ACOM



#WESECUREWHATYOUNEEDTOPROTECT

WWW.LOCHRIN-BAIN.CO.UK SALES@LOCHRIN-BAIN.CO.UK +44 (0)1236 457333

