

Wardale® Two Tier Cycle Shelter BXMW-WAR-TWO-TIER



Standard Unit Dimensions:

Width: 3191mm
Height: 3000mm

Length with Capacities:

3600mm (16 Cycles)
4100mm (20 Cycles)
5000mm (24 Cycles)

Colours/Finishes:

| | | |
|--------------------------------|-----------------------------|-------------------------------|
| | RAL 9006 White Aluminium | RAL 7016 Anthracite Grey |
| BS 4800 10 A 07 Nimbus Grey | RAL 3020 Traffic Red | RAL 9005 Jet Black |
| BS 4800 14 C 39 Holly Green | RAL 1023 Traffic Yellow | BS 4800 00 A 05 Goose Grey |
| RAL 5015 Mid Blue | RAL 5013 Dark Blue | RAL 9016 Traffic White |

The colours shown are a guide only.
Please check a colour chart to see the actual colour.

Product Information

The Wardale® Two Tier cycle shelter uses the best selling Wardale design while utilising the space saving Easi-Riser Two Tier Cycle Parking System (sold separately). Available with Fully Enclosed or Open Extension End frames, The Wardale Two Tier Shelter provides the most protection from the elements of all of our two tier shelters.

Features

- Robust Modular Construction Featuring Load Bearing Purlins
- Welded End Frames and Purlin Section Made From Heavy-Duty Box Section Assembled with Anti-Tamper High Strength Bolts
- Anti-Climb End Frames
- Adjustable Baseplates
- Bottom Purlin Provides Anti-Crawl Bar on Level Surface
- Hot Dipped Galvanized to BS EN ISO 1461:2009
- 4mm Clear View PETg UV Roof and Side Cladding
- Can contribute towards gaining ENE8 credits when used in the appropriate situation, under the Code for Sustainable Homes.
- BREEAM and Code for Sustainable Homes Compliant.

Materials Used

- Framework - Mild Steel
- Cladding - 4mm PETg UV
- Fasteners - Zinc Plated
- Cover Strips - Pre-galvanized steel flat

Broxap Limited, Rowhurst Industrial Estate, Chesterton, Newcastle-under-Lyme, Staffordshire, ST5 6BD T: 01782 564411 E: info@broxap.com W: www.broxap.com



Wardale® Two Tier Cycle Shelter BXMW-WAR-TWO-TIER

Finish Options

- Galvanised to BS EN ISO 1461:2009
- Galvanised to BS EN ISO 1461:2009 & Polyester Powder Coated

Weather Resistance

Cladding is UV Stabilised
Wind resistant to 23m/s

Fire Resistance

Cladding is fire tested to EN ISO 11925-2

Guarantees, Warranties, Design-Life and Life-Expectancies

- 25 year structural guarantee*
- 34 year (min) life expectancy for Hot Dip Galvanizing
- 8-10 year life expectancy on standard powder coatings
- 10-15 year life expectancy on Duplex (Zinc Coated) powder coatings
- 10 years' manufacturers guarantees* on cladding material(s)
- 10 years' warranty* on material (only)
- 12 months' warranty* on parts & labour

*Maintenance and other qualifying criteria apply

Options

- Steel Profile, Trapezoidal Roof Cladding
- Open or Enclosed Extension End Frames
- Extended Adjustable Baseplates for Submerged Fixing
- Swinging Security Gates
- Digital Mechanical or Keyed Locks
- Further Anti Crawl Bars can be fitted Dependant on Surface Level
- Powder Coating to a wide range of colours
- LED or solar lighting
- Multiple Banks to Increase Cycle Capacity
- Full Installation Service













Standard Unit Dimensions:

Width: 3191mm
Height: 3000mm

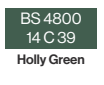
Length with Capacities:

3600mm (16 Cycles)
4100mm (20 Cycles)
5000mm (24 Cycles)

Colours/Finishes:

| | | |
|---|---|---|
|  |  |  |
|  |  |  |
|  |  |  |
|  |  |  |

The colours shown are a guide only.
Please check a colour chart to see the actual colour.

Diagram

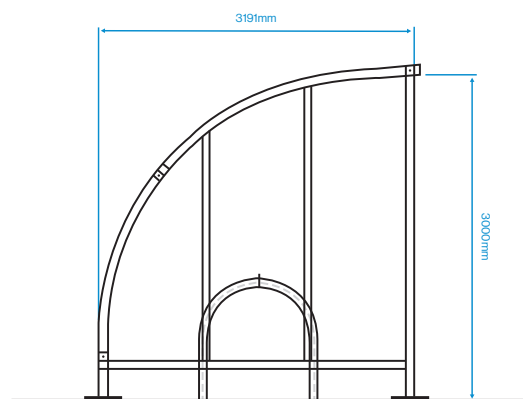

Installation

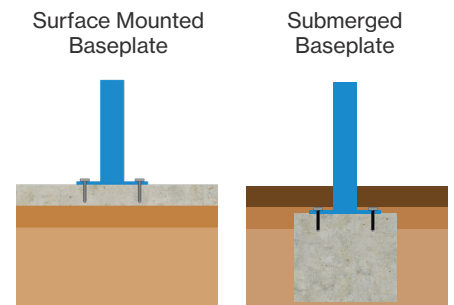

Broxap Limited, Rowhurst Industrial Estate, Chesterton, Newcastle-under-Lyme, Staffordshire, ST5 6BD T: 01782 564411 E: info@broxap.com W: www.broxap.com

