

## Lunar Cycle Shelter BXMW/LUNAR



### Standard Unit Dimensions:

Length: 3600mm/4000mm  
Width: 2500mm  
Height to eaves: 2200mm

### Framework Material:



Redwood Timber

## Product Information

Similar to the Delamere Timber Symmetric Canopy, the Lunar Cycle Shelter offers a natural and stylish solution for bike storage, with a curved symmetric roof and supported by a central column.

## Features

- Symmetric curved roof
- Supplied to site flat packed
- Groundworks : Length x Width of Shelter + 500mm Minimum
- Fire rated treatment is available for an additional cost
- Root fixed or Surface mounted baseplates

## Materials Used

- Redwood timber treated for external use
- Roof Cladding : 4mm PETg UV ClearView

## Weather Resistance

Cladding is UV Stabilised  
Wind resistant to 23m/s

## Fire Resistance

Cladding is fire tested to '1Y' for BS 476

Broxap Limited, Rowhurst Industrial Estate, Chesterton, Newcastle-under-Lyme, Staffordshire, ST5 6BD T: 01782 564411 E: info@broxap.com W: www.broxap.com



ISO 9001  
Quality  
Management  
Systems  
CERTIFIED

ISO 14001  
Environmental  
Management  
CERTIFIED

ISO 45001  
Occupational  
Health and Safety  
Management  
CERTIFIED



### Guarantees, Warranties, Design-Life and Life-Expectancies

- 25 year structural guarantee\*
- 34 year (min) life expectancy for Hot Dip Galvanizing
- 8-10 year life expectancy on standard powder coatings
- 10-15 year life expectancy on Duplex (Zinc Coated) powder coatings
- 10 years' manufacturers guarantees\* on cladding material(s)
- 10 years' warranty\* on material (only)
- 12 months' warranty\* on parts & labour
- 10 year timber guarantee\*

\*Maintenance and other qualifying criteria apply

### Options

- Varied Range of Cycle Racks
- Varied Range of Cycle Stands
- Fixing: Root fixed or Surface mounted baseplates
- Full installation service
- Available in 3600mm and 4100mm lengths

### Diagram

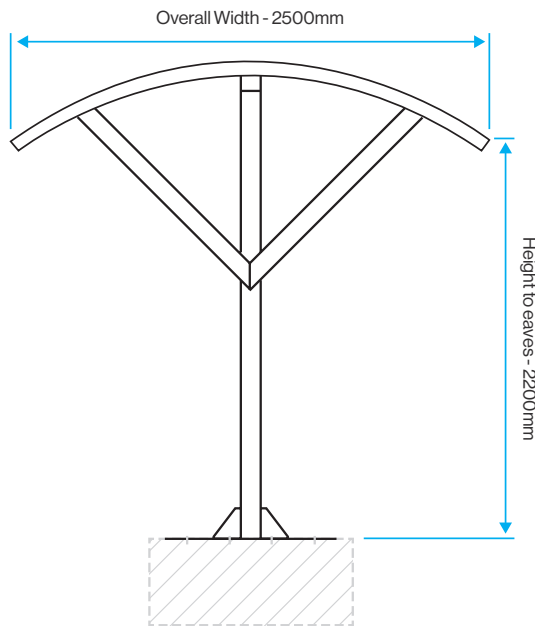

### Installation

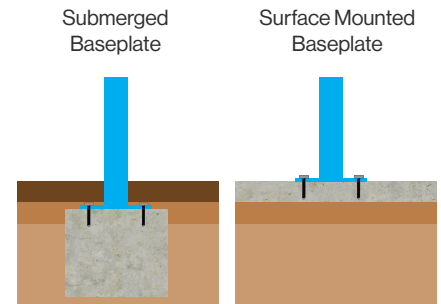

#### Standard Unit Dimensions:

Length: 3600mm/4000mm  
Width: 2500mm  
Height to eaves: 2200mm

#### Framework Material:



Redwood Timber

Broxap Limited, Rowhurst Industrial Estate, Chesterton, Newcastle-under-Lyme, Staffordshire, ST5 6BD T: 01782 564411 E: info@broxap.com W: www.broxap.com



ISO 9001  
Quality  
Management  
Systems  
CERTIFIED  
IRM 202378

ISO 14001  
Environmental  
Management  
CERTIFIED  
EMS 45525

ISO 45001  
Occupational  
Health and Safety  
Management  
CERTIFIED  
OHS 547079

