

Installation Instructions

Install Instrument with 1.5m free space (from widest point) around it.

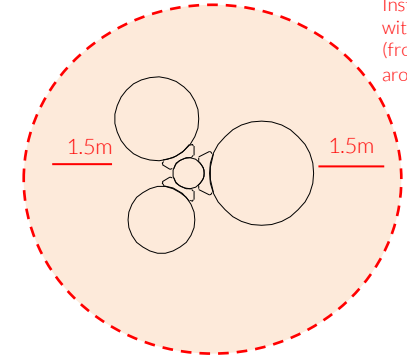

1. Attach the steel leg to each of the bongos with the M10x50 security screws, square washers and PU mounts. (See Assembly Guide)

2. Attach Ground Fixings to legs. (1.1) (See Ground Fix Post Installation Sheet)

3. Excavate 1 hole for the Steel leg 250mm diameter by 300mm deep, in desired location upon decision from customer.

4. Locate (lower) leg into hole making sure they are vertical and level prior to concreting in place.

5. Once happy with location of the Instrument, fill hole using rapid hardening concrete. Be sure to compact concrete around legs and leave to dry according to manufactures guidelines.

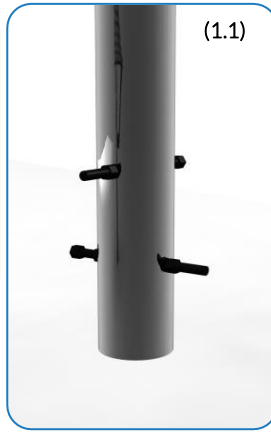
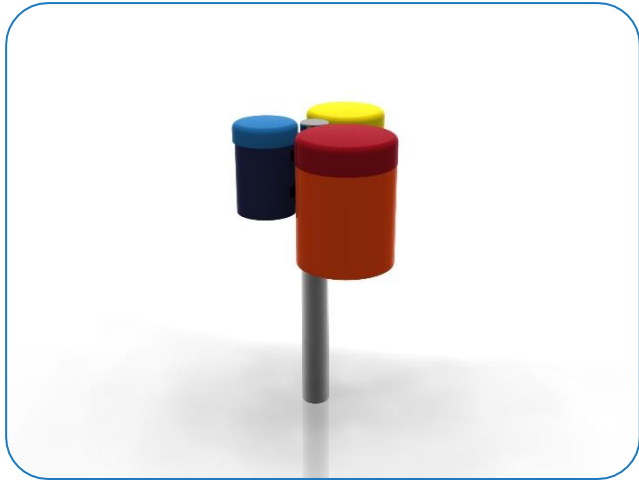
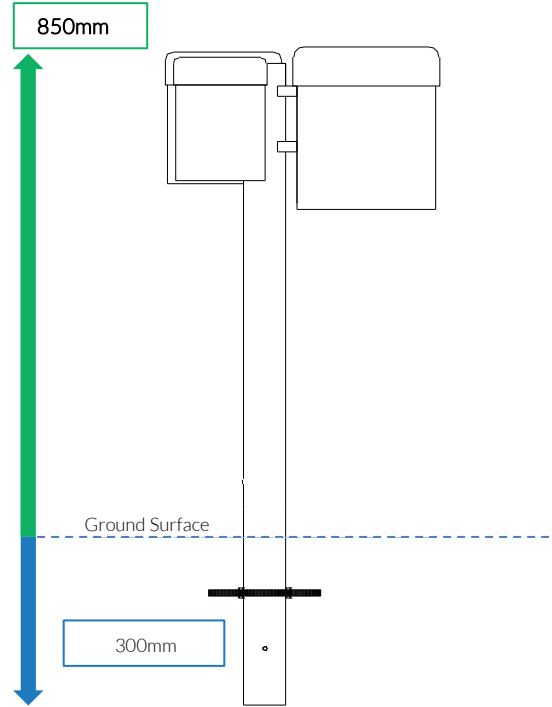

Ground Fixed Rainbow Trio Bongos Page 1 of 3



Components:

- x6
M10x50 Security Screw
- x6
M10x50x3 Square washer
- x4
PU 200 Mount
- x2
PU 250 Mount

Metric Conversion:
250mm/ 10"
850mm/ 33"
1.5m/ 59"

Weight of heaviest part 7 kg (bongos)



Played with hands

Ground Fix Components:

- x2
M10x200 Threaded Bar
- x4
M10 Nut



Spares available from percussionplay.com or from your local distributor

15 Kg

Tools:
 x1

COMPONENTS LIST:

- M 10x50 Pin torx X6
- M 10x50x3 square washer X6
- PU MOUNT 200 X4
- PU MOUNT 250 X2
- M 10 Nut X4
- M 10x200 Threaded Bar X2

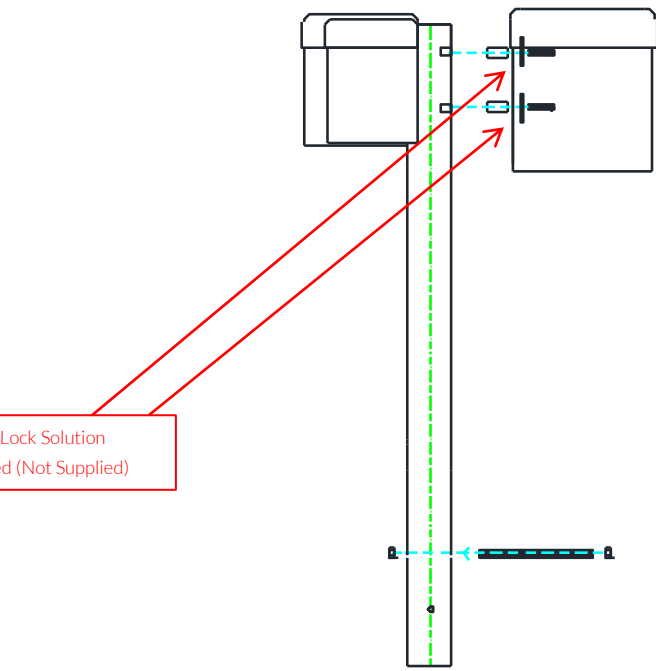
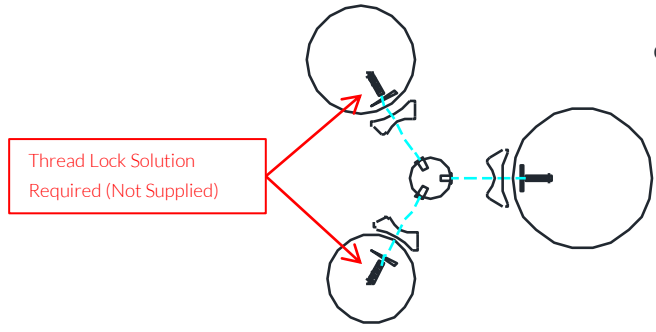

PPRTBON FRONT

Ground Fixed
 Rainbow Trio Bongos
 Page 2 of 3



Components:

- x6
- M10x50 Security Screw
- x6
- M10x50x3 Square washer
- x4
- PU 200 Mount
- x2
- PU 250 Mount

Thread Lock Solution
 Required (Not Supplied)



Ground Fix
 Components:

- x2
- M10x200 Threaded Bar
- x4
- M10 Nut



Spares available from
percussionplay.com or from your
 local distributor

14.8 Kg
 15 Kg
 20 Kg

Ground Fix Post Installation

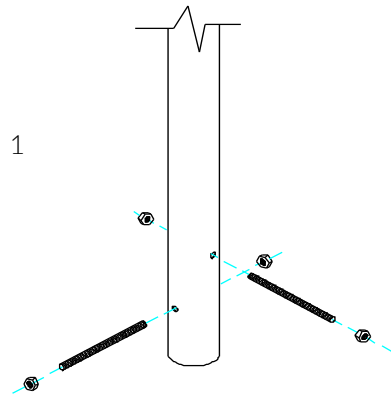

1
Insert M10x 200 Threaded bar into pre drilled holes in Ground Fixing Post

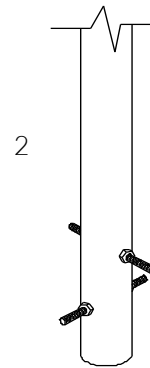

2
Fix M10x 200 Threaded bar in place using M10 Nuts

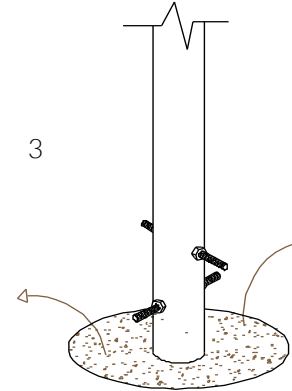

3
Excavate a hole with a 250mm diameter tapering down to 350mm diameter and 350mm depth

Foundations should not present a hazard. These foundations are recommended as a guide, for more information on foundation details for various surface see Part 1 of BS EN 1176.

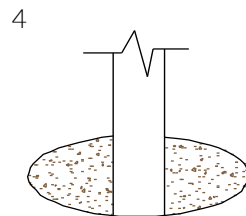

4
Compact base of hole with 50mm of aggregate. Lower ground Fix post attached of instrument into hole (check instrument straight and level before filling with concrete)

300mm min depth

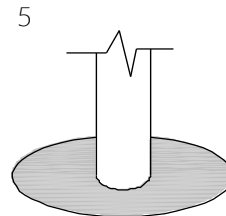

5
Fill hole with fast drying concrete to manufacturers specifications.

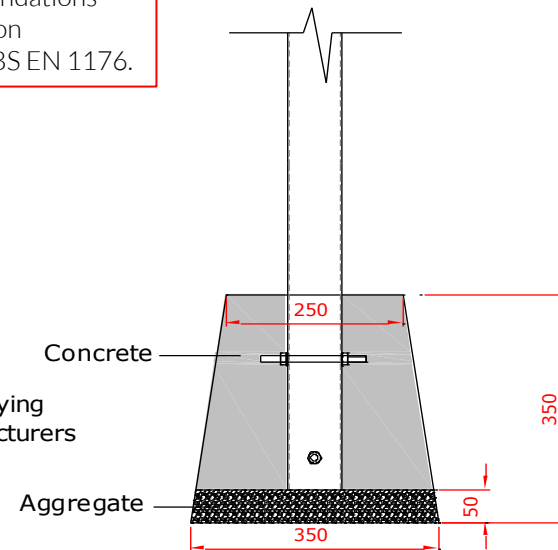

Ground Fixed Rainbow Trio Bongos Page 3 of 3



Components:



Metric Conversion:
50mm/ 2"
250mm/ 10"
350mm/ 14"

