

Installation Instructions

Surface Fixed
Petal Drum
Page 1 of 3

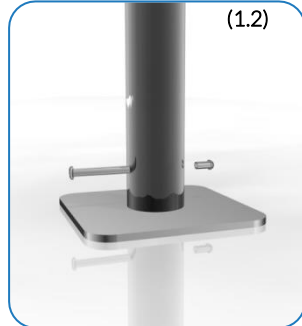

Weight of heaviest part 7.5kg

1. Instrument will arrive on site fully assembled. **(1.1)**
(See Assembly Guide)

2. Attach Surface Fixing posts to legs. **(1.2)** (See Surface Fix Post Installation Sheet)

3. **Locate Plate** in desired location and mark holes to fix to desired surface.

4. **Fix to Surface** using recommended ground anchors not supplied

5. Make sure all fixings are covered and secure using cover caps provided.

6. Attach the 1 of the beaters to each of the saddle strap on the hex frame. **(1.3)**

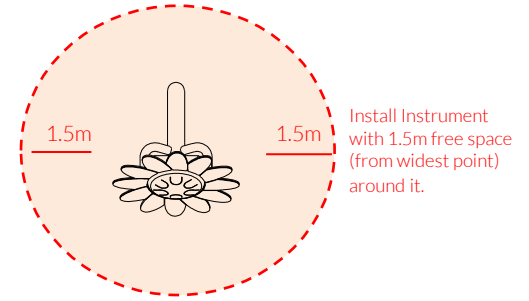

Install Instrument with 1.5m free space (from widest point) around it.

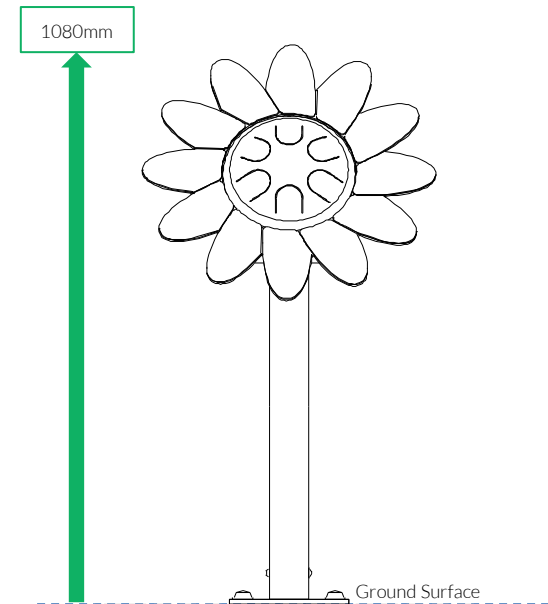

Instrument Components:



 x4
M6x20 Security Screw

 x2
M6 Saddle Strap

Metric Conversion:
1080mm/ 42.5"
1.5m/ 59"



Surface Fix Components:



 x1
 x1
M10x70 Security Screw M10 Barrel Nut



Spares available from percussionplay.com or from your local distributor

17 Kg

Tools:

 x1
 x2

Install 3X PU Inserts into each arm before installing petal section

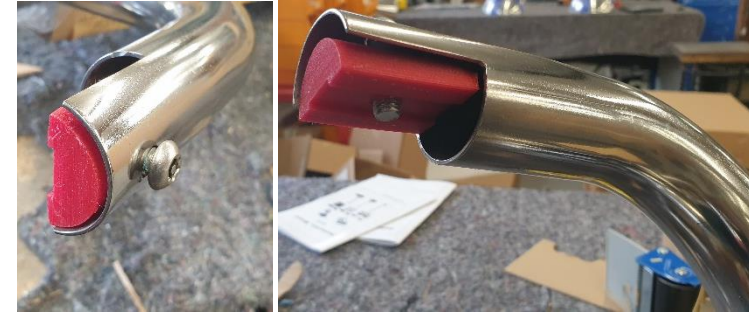

COMPONENTS LIST:

-  2 Part Cover Cap X8
-  M8X30 Pin trox X3
-  Saddle Strap X2
-  M6x20 Pin torx X6
-  M10x70 Pin torx X1
-  M10 Barrel Nut Pin torx X1
-  Petal Drum Frame Insert X3

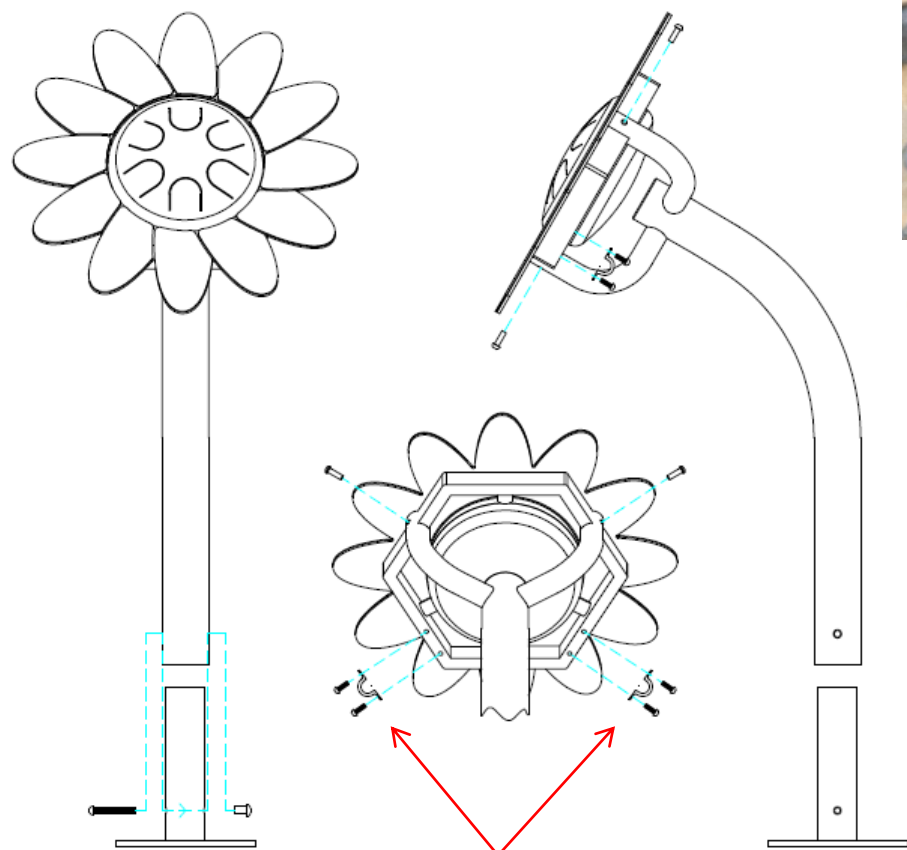

Thread Lock Solution Required (Not Supplied)

Surface Fixed
Petal Drum
Page 2 of 3



Instrument Components:

-  x4
M6x20 Security Screw
-  x2
M6 Saddle Strap

Thread Lock Solution Required (Not Supplied)



Pair Babel Beaters X1

Surface Fix Components:

-  x1
M10x70 Security Screw
-  x1
M10 Barrel Nut



Spares available from percussionplay.com or from your local distributor

17 Kg

Surface Fixed
Petal Drum
Page 3 of 3



Components:



x1

M10 Barrel Nut



x1

M10x70 Security Screw

Thread Lock Solution
Required (Not Supplied)

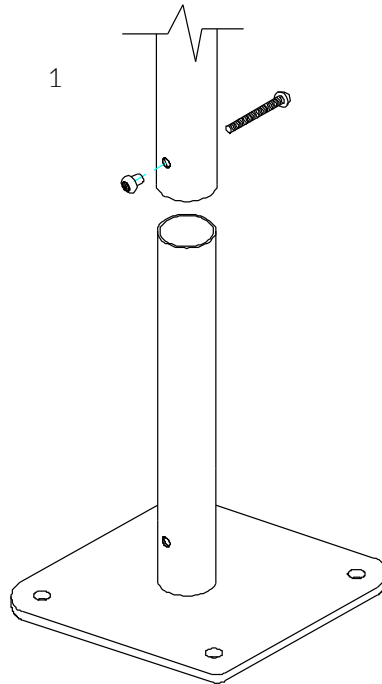

1
Locate the Surface fix Plate into the leg of the instrument.

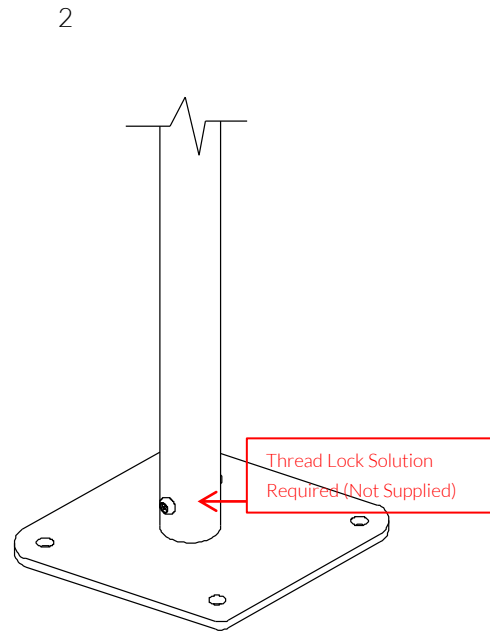

2
Fix instrument to Surface fix plate using M10 bolt and Barrel Nut and use **thread locking solution** to prevent fixings working loose.

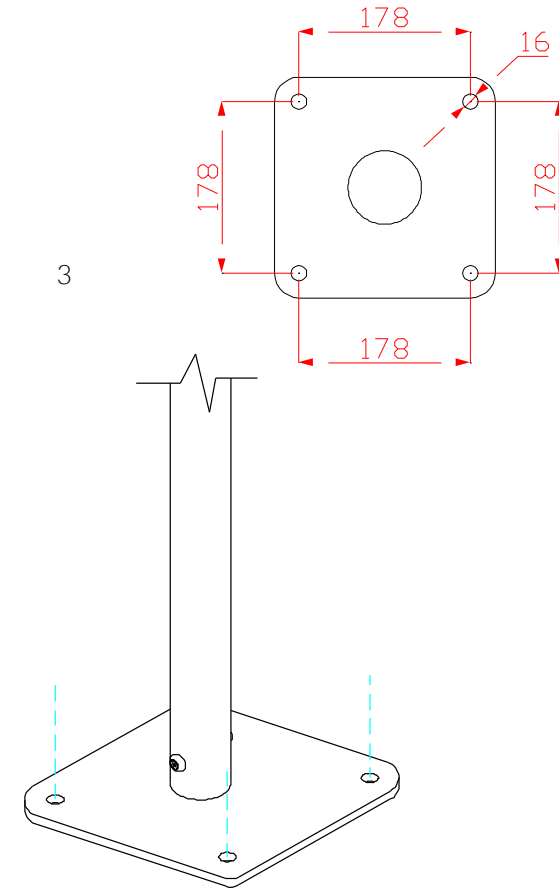

3
Fix Surface Plate to the ground surface **Ground Anchors Not provided** cover fixings with caps provided



MADE IN
BRITAIN

BSEN 1176

