

High Density Cycle Rack BXMW/HD







Standard Unit Dimensions:

Width: 1540mm
Height: 1742mm

Length with Capacities:

1750mm (10 Cycles)
2100mm (12 Cycles)
2450mm (14 Cycles)

Colours/Finishes:

		
Galvanised Only	White Aluminium	Anthracite Grey
		
BS 4800 10 A 07 Nimbus Grey	Traffic Red	Jet Black
		
BS 4800 14 C 39 Holly Green	Traffic Yellow	Goose Grey
		
Mid Blue	Dark Blue	Traffic White

The colours shown are a guide only.
Please check a colour chart to see the actual colour.

Product Information

The High Density Cycle Rack is designed to increase cycle parking density where space is limited with a specific focus on inner city and urban areas. Note cycle locking hoop for securing cycles to stand.

Features

- Designed to significantly increase the cycle parking density where space is limited, specifically for inner city and urban areas where space is at a premium.
- Access from both sides and cycles interlink on a semi vertical basis.
- The footprint of the rack almost doubles the capacity when comparing it to space required by Sheffield or Harrogate style stand installations.
- The trough is a revolutionary shape which accommodates a wide variety of tyres (racing, hybrid, mountain bike style, etc) to be held firmly when placed in the rack.
- Can contribute towards gaining ENE8 credits when used in the appropriate situation, under the Code for Sustainable Homes.
- BREEAM and Code for Sustainable Homes Compliant.

Materials Used

- Framework - Mild Steel

Finish Options

- Galvanised to BS EN ISO 1461:2009
- Galvanised to BS EN ISO 1461:2009 & Polyester Powder Coated

Broxap Limited, Rowhurst Industrial Estate, Chesterton, Newcastle-under-Lyme, Staffordshire, ST5 6BD T: 01782 564411 E: info@broxap.com W: www.broxap.com



ISO 9001
Quality Management Systems
CERTIFIED

ISO 14001
Environmental Management
CERTIFIED

ISO 45001
Occupational Health and Safety Management
CERTIFIED



High Density Cycle Rack BXMW/HD

Guarantees, Warranties, Design-Life and Life-Expectancies

- 34 year (min) life expectancy for Hot Dip Galvanizing
- 8-10 year life expectancy on standard powder coatings
- 10-15 year life expectancy on Duplex (Zinc Coated) powder coatings
- 12 months' warranty* on parts & labour

*Maintenance and other qualifying criteria apply

Options

- Available in a range of size options

Diagram

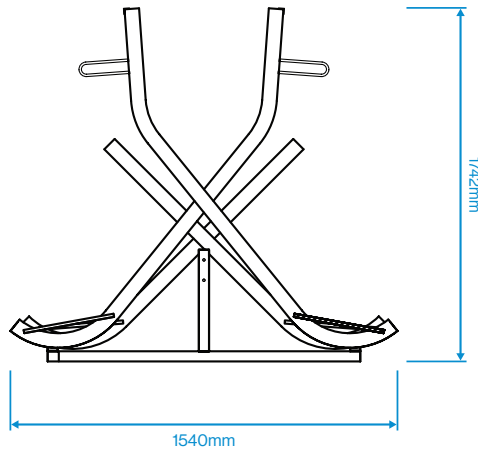

Standard Unit Dimensions:

Width: 1540mm
Height: 1742mm

Length with Capacities:

1750mm (10 Cycles)
2100mm (12 Cycles)
2450mm (14 Cycles)

Colours/Finishes:

Galvanised Only	RAL 9006 White Aluminium	RAL 7016 Anthracite Grey
BS 4800 10 A 07 Nimbus Grey	RAL 3020 Traffic Red	RAL 9005 Jet Black
BS 4800 14 C 39 Holly Green	RAL 1023 Traffic Yellow	BS 4800 00 A 05 Goose Grey
RAL 5015 Mid Blue	RAL 5013 Dark Blue	RAL 9016 Traffic White

The colours shown are a guide only.
Please check a colour chart to see the actual colour.

Broxap Limited, Rowhurst Industrial Estate, Chesterton, Newcastle-under-Lyme, Staffordshire, ST5 6BD T: 01782 564411 E: info@broxap.com W: www.broxap.com



ISO 9001
Quality Management Systems
CERTIFIED

ISO 14001
Environmental Management
CERTIFIED

ISO 45001
Occupational Health and Safety Management
CERTIFIED

