

Installation Instructions



1. Attach the steel legs to the base of the instrument with the M8 Nyloc Nuts and 2 part security caps. (1.1) (See Assembly Guide)

2. Attach Ground Fixing posts to legs (1.2) (See Ground Fix Post Installation Sheet)

3. Excavate 1 hole for the Steel legs 250mm diameter by 400-550mm deep depending on Key stage, in desired location upon decision from customer.

4. Locate (lower) legs into holes making sure they are vertical and level prior to concreting in place.

5. Once happy with location of the Instrument, fill holes using rapid hardening concrete. Be sure to compact concrete around legs and leave to dry according to manufactures guidelines.

6. Attach the 1 pair of beater to the saddle strap on the leg. (1.3)

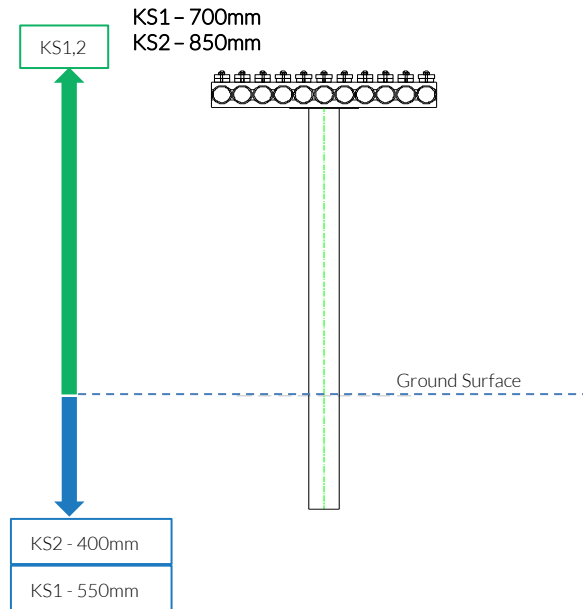
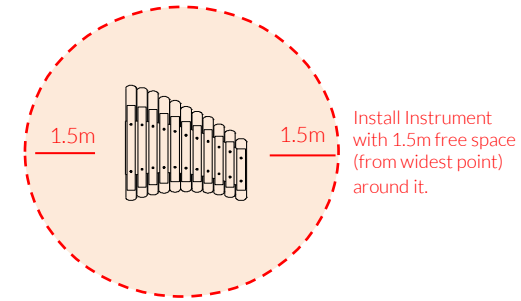

Weight of heaviest part 7kg (Cadenza) SD
Weight of heaviest part 13kg (Cadenza) HD

Ground Fixed

Cadenza
Page 1 of 3

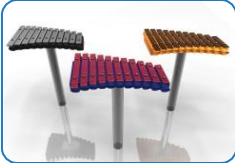

Components:

- x4
M8 Nyloc Nut
- x2
M6x20 Security Screw
- x4
2 Part Cover Cap
- x1
M6 Saddle Strap

Metric
Conversion:
250mm/ 10"
400mm/ 15 3/4"
550mm/ 21 21/32"
700mm/ 27 9/16"
850mm/ 33 15/32"
1.5m/ 59"



Pair Small Red Beaters X1



Ground Fix Components:



Spares available from percussionplay.com or from your local distributor

12 - 18Kg

Tools:

 x1
  x1
 TX 30 Driver Bit TX 40 Driver Bit



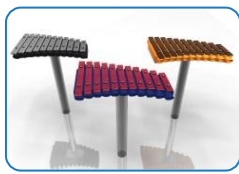



Ground Fixed
Cadenza
Page 2 of 3

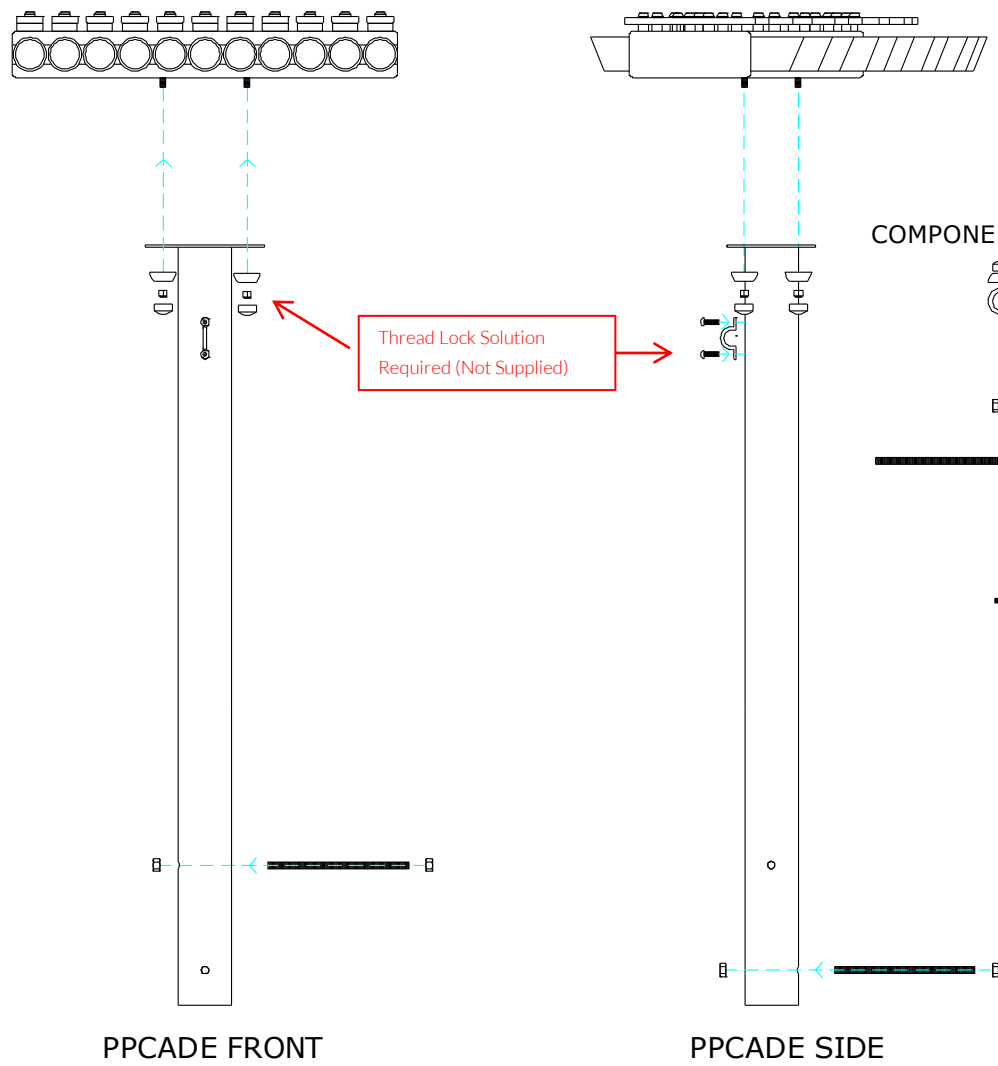

- Components:**
-  x4
M8 Nyloc Nut
 -  x2
M6x20 Security Screw
 -  x4
2 Part Cover Cap
 -  x1
M6 Saddle Strap

Thread Lock Solution
Required (Not Supplied)





- COMPONENTS LIST:**
-  2 Part Cover Cap X4
 -  M8 Nyloc nut X4
 -  M10 Nut X4
 -  M10x200 Threaded Bar X2
 -  Saddle Strap X1
 -  M6x20 Pin torx X2



Pair Small Red Beaters X1

Ground Fix Components:

 x2
 M10x200 Threaded Bar

 x4
 M10 Nut

Spares available from percussionplay.com or from your local distributor

14 Kg

Ground Fix Post Installation

Foundations should not present a hazard. These foundations are recommended as a guide, for more information on foundation details for various surface see Part 1 of BS EN 1176.

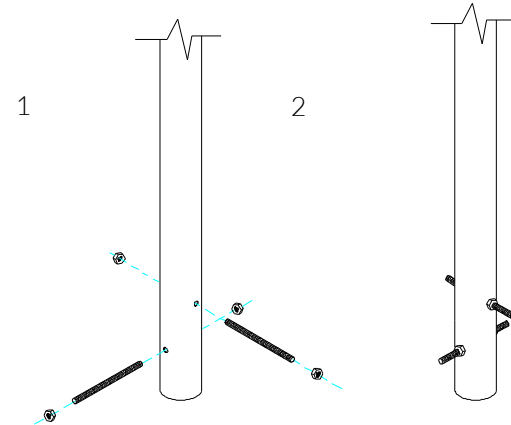

1
2
Insert M10x200 Threaded bar into pre drilled holes in Ground Fixing Post

Fix M10x 200 Threaded bar in place using M10 Nuts

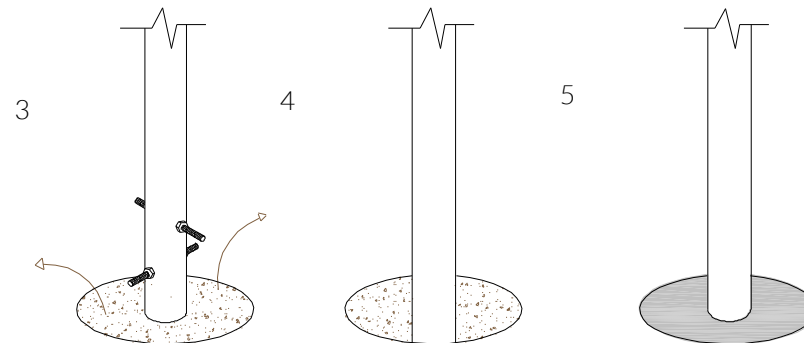

3
4
5
Excavate 1 holes with a 250mm diameter tapering down to 350mm diameter and 450mm depth

Compact base of hole with 50mm of aggregate. Lower ground Fix post attached to instrument into hole (check instrument straight and level before filling with concrete)

Fix hole with fast drying concrete to manufacturers specifications.

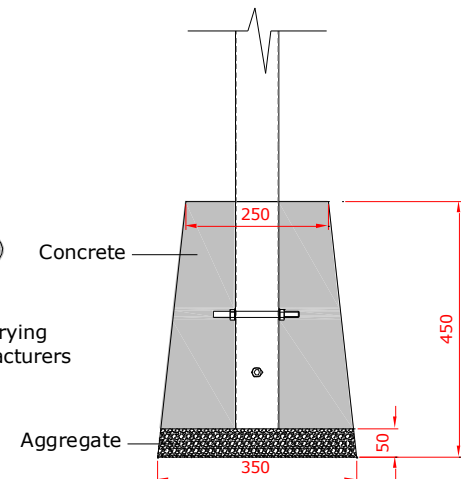

400mm min depth



Ground Fixed

Cadenza
Page 3 of 3

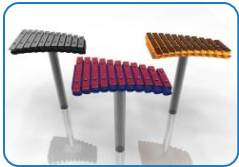

Components:

 x2
M10x200
Threaded Bar

 x4
M10 Nut

Metric Conversion:
50mm/ 2"
250mm/ 10"
350mm/ 14"
400mm/ 16"
450mm/ 18"

