



Standard Unit Dimensions:

Length: 4100mm
Width: 2200mm
Height: 2200mm

Length with Capacities:

4100mm (10 cycles)

Colours/Finishes:

The colours shown are a guide only.
Please check a colour chart to see the actual colour.

Product Information

A Contemporary modular Cycle Shelter, the Burntwood offers a stylish alternative to the PETg and Polycarbonate shelters. Integral Guttering offers built in rainwater management. While roof cladding constructed of pre-finished steel offers a robust design which also offers vandal resistant properties, while maintaining an appealing, eye catching finish.

Features

- Robust modular construction
- Welded end frames and pulin section made from heavy-duty box section assembled with anti-tamper high strength bolts
- Anti-climb end frames
- Submerged baseplates
- Hot Dipped Galvanized to BS EN ISO 1461:2009
- Trapezoidal Roof Cladding
- Bream Compliant Configurations

Materials Used

- Framework - Mild Steel
- Cladding - Steel Profile, Trapezoidal roof cladding
- Fasteners - Zinc Plated
- Cover Strips - Pre-galvanized steel flat

Finish Options

- Hot-Dip Galvanized to BS EN ISO 1461:2009
- Hot-Dip Galvanized & Polyester Power Coated 60mm-120mm dft
- Hot-Dip Galvanized with Duplex (Zinc Coated) Powder Coating (coastal) 180-240 overall dft

Broxap Limited, Rowhurst Industrial Estate, Chesterton, Newcastle-under-Lyme, Staffordshire, ST5 6BD T: 01782 564411 E: info@broxap.com W: www.broxap.com



ISO 9001
Quality
Management
Systems
CERTIFIED

ISO 14001
Environmental
Management
CERTIFIED

ISO 45001
Occupational
Health and Safety
Management
CERTIFIED



Burntwood Cycle Shelter BXMW/BURNT

Weather Resistance

Cladding is UV Stabilised
Wind resistant to 23m/s

Fire Resistance

Cladding is fire tested to '1Y' for BS 476

Guarantees, Warranties, Design-Life and Life-Expectancies

- 25 year structural guarantee*
- 34 year (min) life expectancy for Hot Dip Galvanizing
- 8-10 year life expectancy on standard powder coatings
- 10-15 year life expectancy on Duplex (Zinc Coated) powder coatings
- 10 years' manufacturers guarantees* on cladding material(s)
- 10 years' warranty* on material (only)
- 12 months' warranty* on parts & labour

*Maintenance and other qualifying criteria apply

Options

- Opal Cladding to Roof and Sides
- Powder Coating to a wide range of colours
- LED or solar lighting
- Full Installation Service
- Varied Range of Cycle Racks
- Varied Range of Cycle Stands

Standard Unit Dimensions:

Length: 4100mm
Width: 2200mm
Height: 2200mm

Length with Capacities:

4100mm (10 cycles)

Colours/Finishes:

Galvanised Only	RAL 9006 White Aluminium	RAL 7016 Anthracite Grey
BS 4800 10 A 07 Nimbus Grey	RAL 3020 Traffic Red	RAL 9005 Jet Black
BS 4800 14 C 39 Holly Green	RAL 1023 Traffic Yellow	BS 4800 00 A 05 Goose Grey
RAL 5015 Mid Blue	RAL 5013 Dark Blue	RAL 9016 Traffic White

The colours shown are a guide only.
Please check a colour chart to see the actual colour.

Diagram

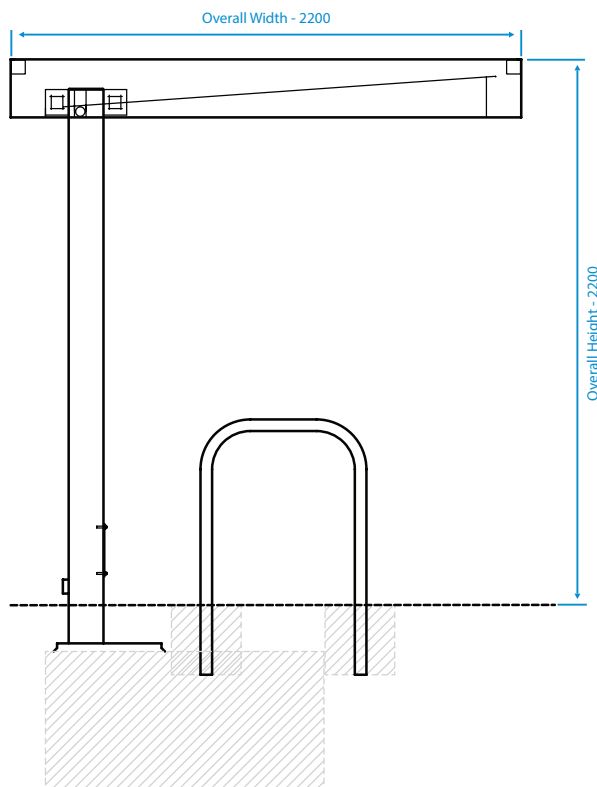

Installation

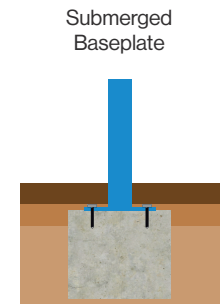

Broxap Limited, Rowhurst Industrial Estate, Chesterton, Newcastle-under-Lyme, Staffordshire, ST5 6BD T: 01782 564411 E: info@broxap.com W: www.broxap.com



ISO 9001
Quality Management Systems
CERTIFIED

ISO 14001
Environmental Management
CERTIFIED

ISO 45001
Occupational Health and Safety Management
CERTIFIED

