

# Quantum Flooring Solutions - Product Drawing

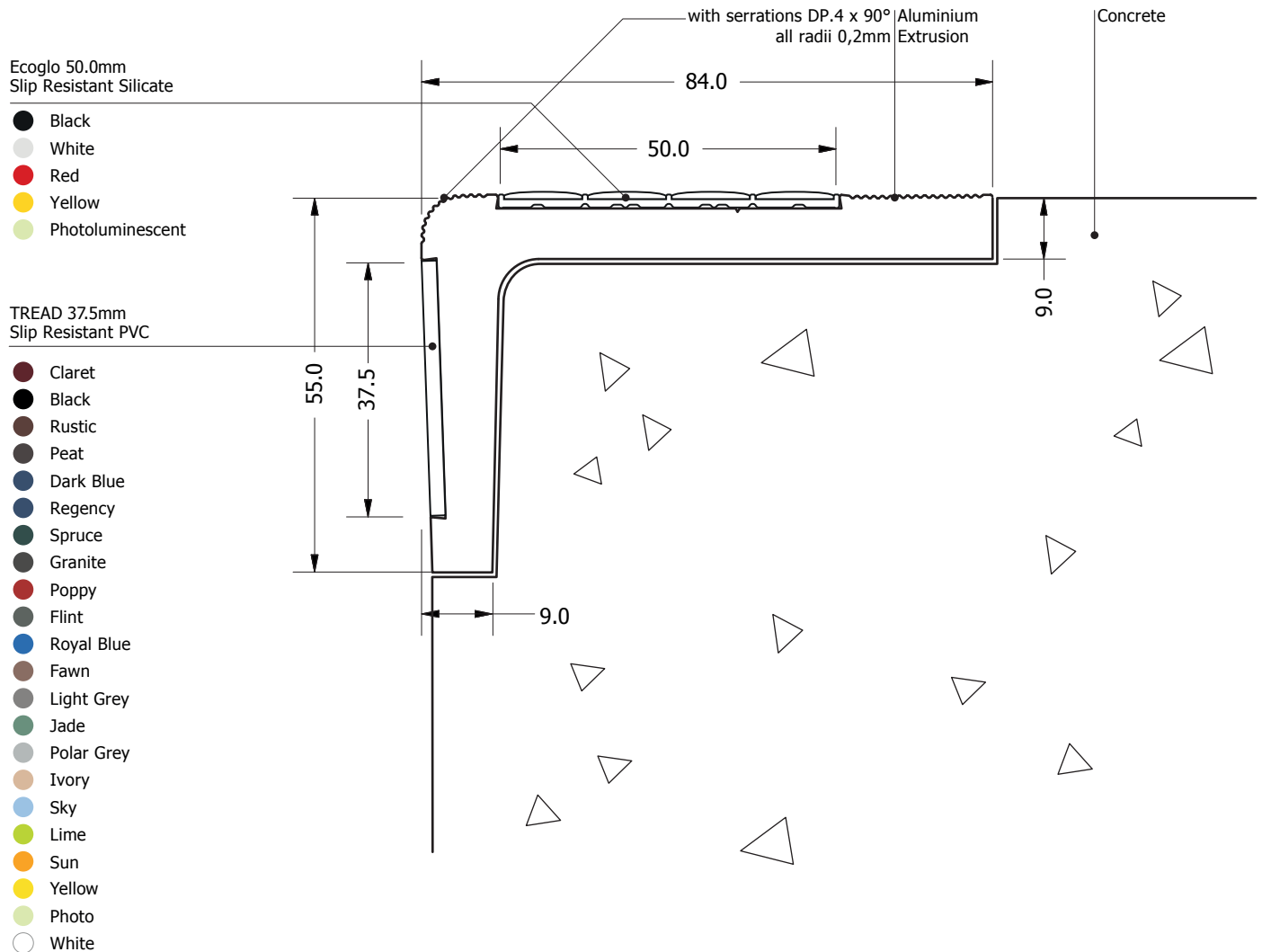

Quantum Profile Systems Ltd.  
 Salmon Fields, Royton, Oldham, Lancashire, OL2 6JG  
 Tel: 0161 627 4222 Fax: 0161 627 4333 email: info@quantum-ps.co.uk

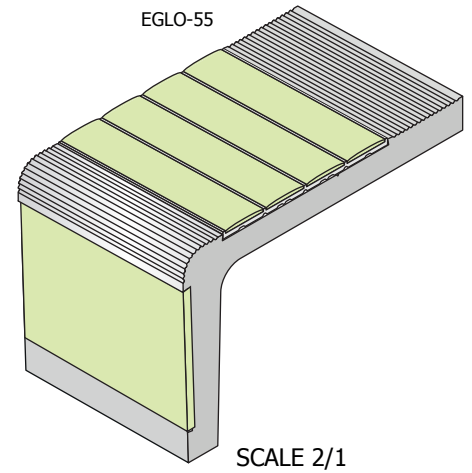

Product: Aluminium Set-in Nosing / Extrusion

Scale: 1:1

Material: Aluminium



QPSL

This drawing should be used for illustration purposes only. It can not be used as a specification of the part.  
 For more information please call +44 (0) 161 627 4222 or mailto CustomerService@quantum-ps.co.uk  
 Copyright © 2015 Quantum Profile Systems Limited. All rights reserved.

Date: 02/02/2016  
 Author: diane.luther  
 File: Alu-set-in.pdf