



FREE UK DELIVERY



SITE SURVEYS



10 YEAR GUARANTEE



INSTALLATION SERVICE



MADE IN BRITAIN

# GAS ASSISTED TWO TIER CYCLE RACK

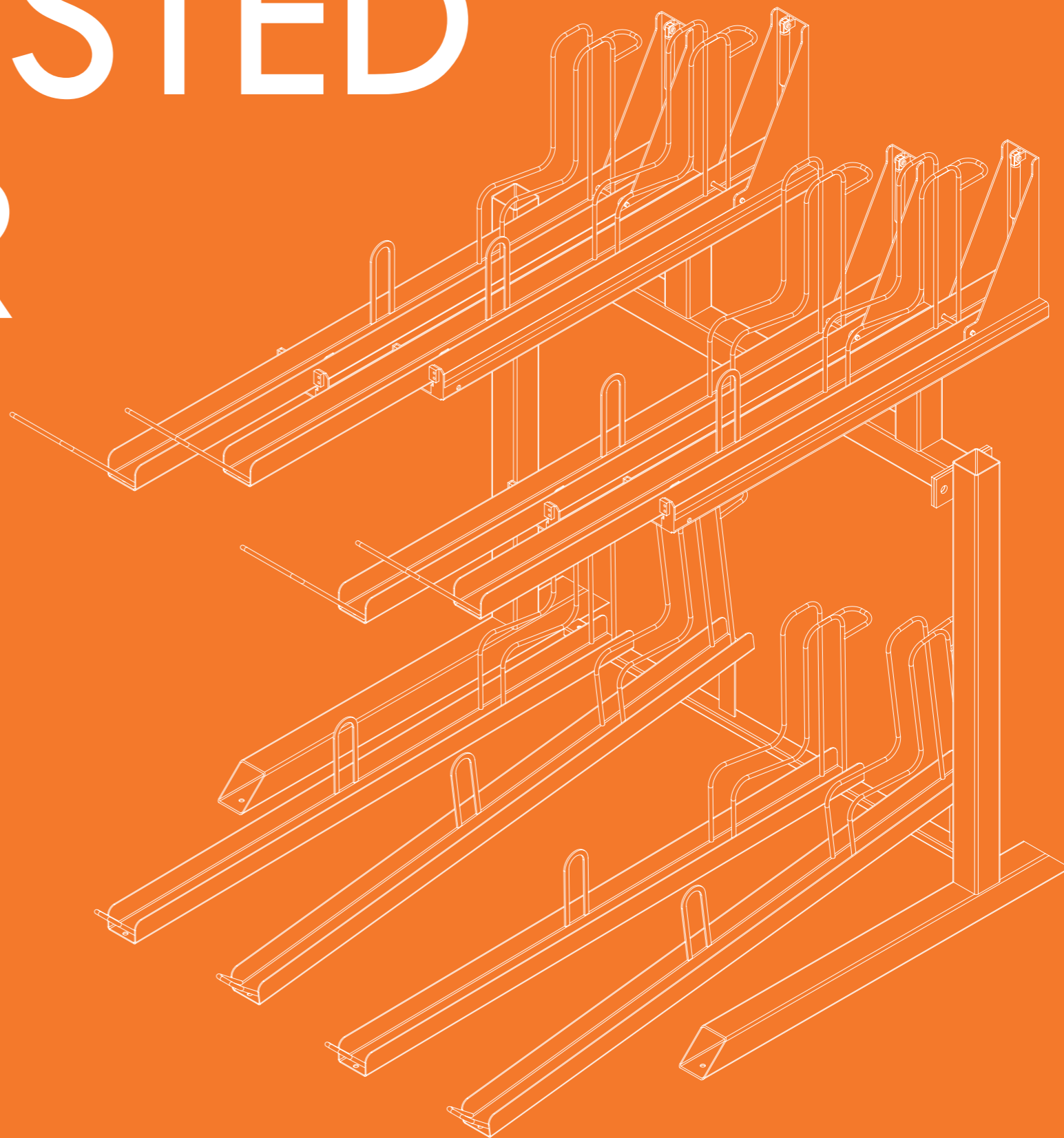

THE  
**BIKE STORAGE**  
COMPANY

SPECIFICATION DOCUMENT

0800 246 1723

[www.thebikestoragecompany.co.uk](http://www.thebikestoragecompany.co.uk)

[hello@thebikestoragecompany.co.uk](mailto:hello@thebikestoragecompany.co.uk)

306 Harbour Yard, London, SW10 0XD.

Registered in England No. 9189322.



# GAS ASSISTED TWO TIER CYCLE RACK

0800 246 1723  
thebikestoragecompany.co.uk

THE BIKE STORAGE COMPANY

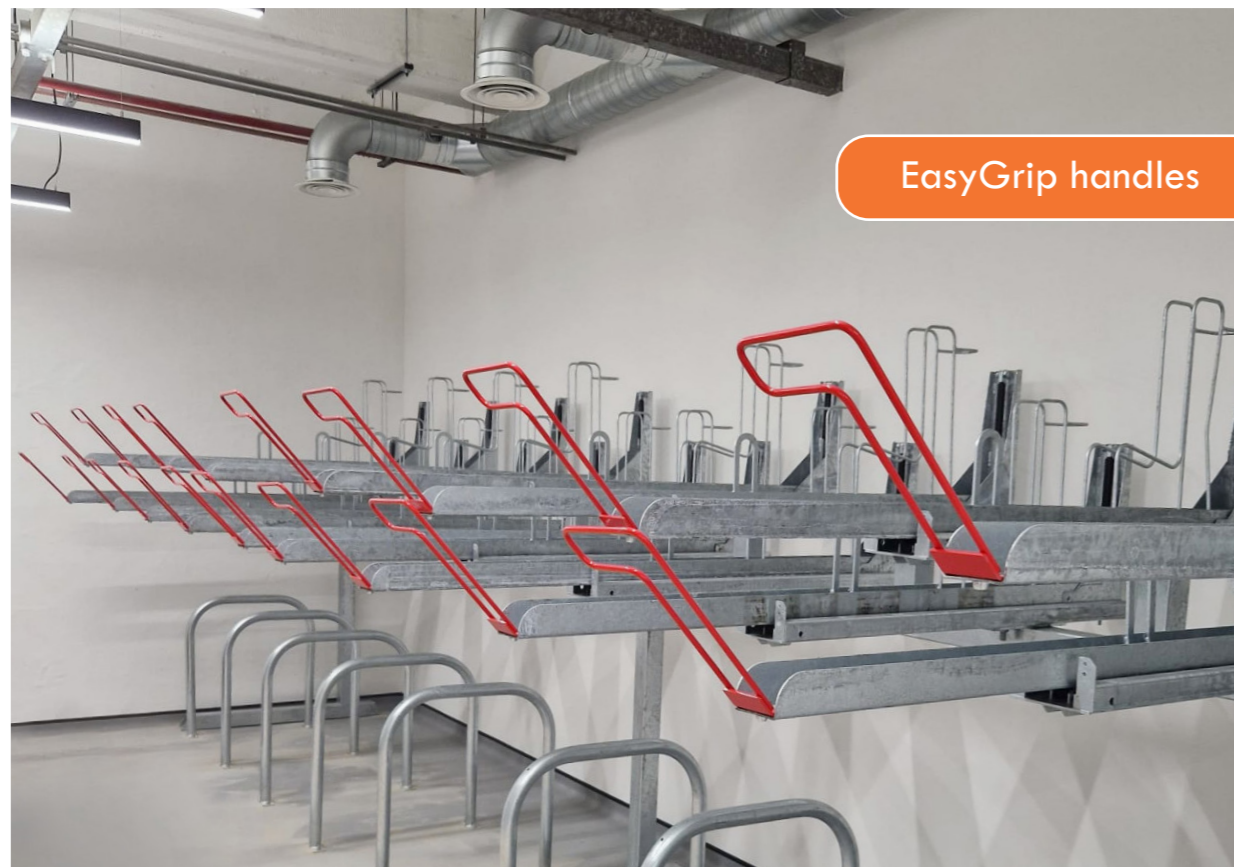

TOP

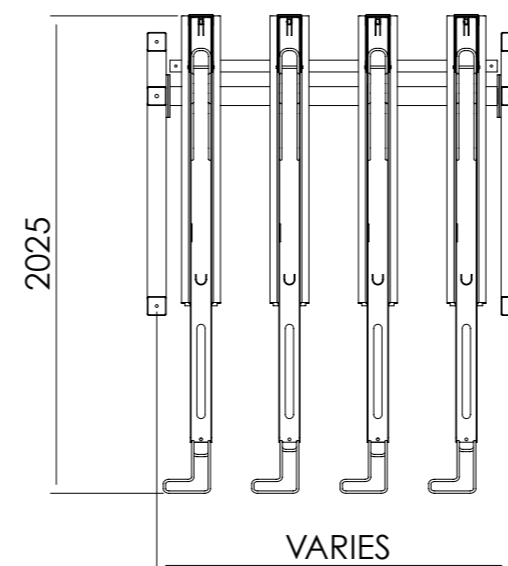

SIDE

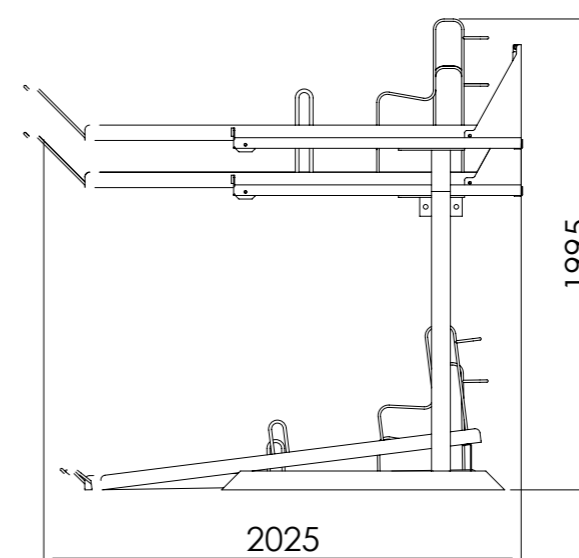

FRONT

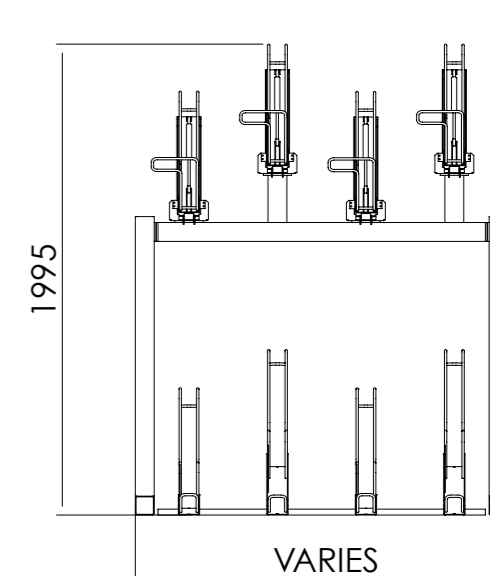

The Gas Assisted Two Tier Bike Rack provides convenient high density bicycle parking alongside the ultimate user-friendly experience. Each upper-level rack has a tamper-proof gas strut integrated at the back; this assistance eliminates all strain from the bike loading process and has been rated up to 30kg. Both the bike's wheels and frame can be secured to the locking point, ensuring a high security cycle rack. Gas strut tested to over 30,000 uses. Supports any bike with a maximum tyre width of 64mm. This rack can help you achieve BREEAM Compliant status.

## FEATURES

- UK Manufactured
- Hot Dipped Galvanised to BS EN ISO 1461:2022
- Minimum height required 2500mm
- Gas-assisted counterbalance lifting mechanism
- Tested to over 30,000 uses
- Allows for both the wheels and the frame to be locked to the rack
- Code for Sustainable Homes compliant and BREEAM Compliant
- 375mm spacing between racks and a staggered height design allows for great utilisation of space whilst
- Allowing easy access to bikes
- Single or back-to-back versions available
- Manufactured against your dimensions and room layout at no extra cost
- Full site visit and layout design provided free of charge
- Free delivery

## OPTIONAL EXTRA

- Easy grip red handle
- Lower level channels (rack is provided as standard with Sheffield Stands for lower level)
- Intergrated back-to-back channel arrangement
- Powder coating (excluding inner channel)

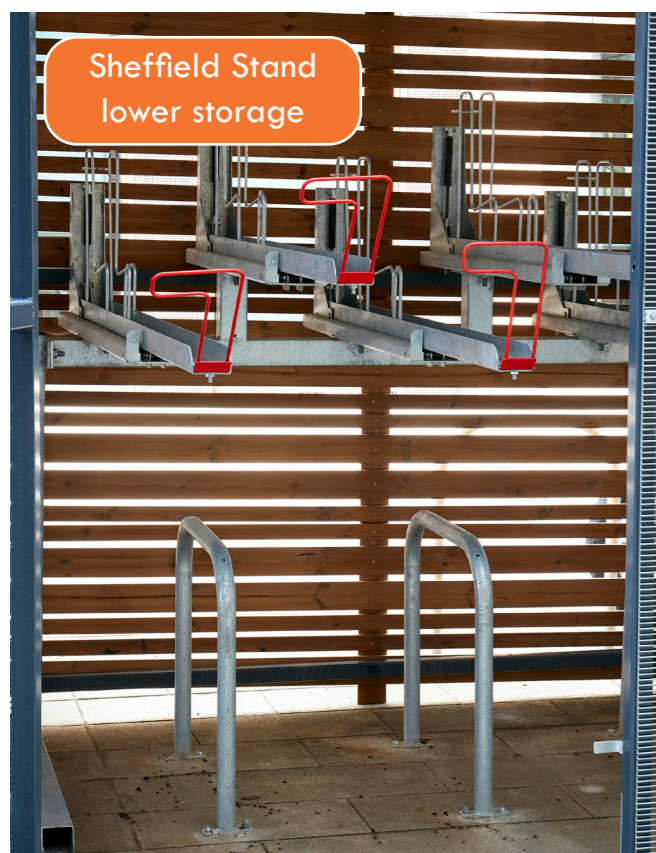

- Install Requirements**
- Rack to rack aisle width: 1635mm
  - Rack to wall aisle width: 1635mm
  - Centre of rack leg to wall tolerance: 300mm
  - Minimum ceiling height: 2500mm

**SPACING REQUIREMENTS**

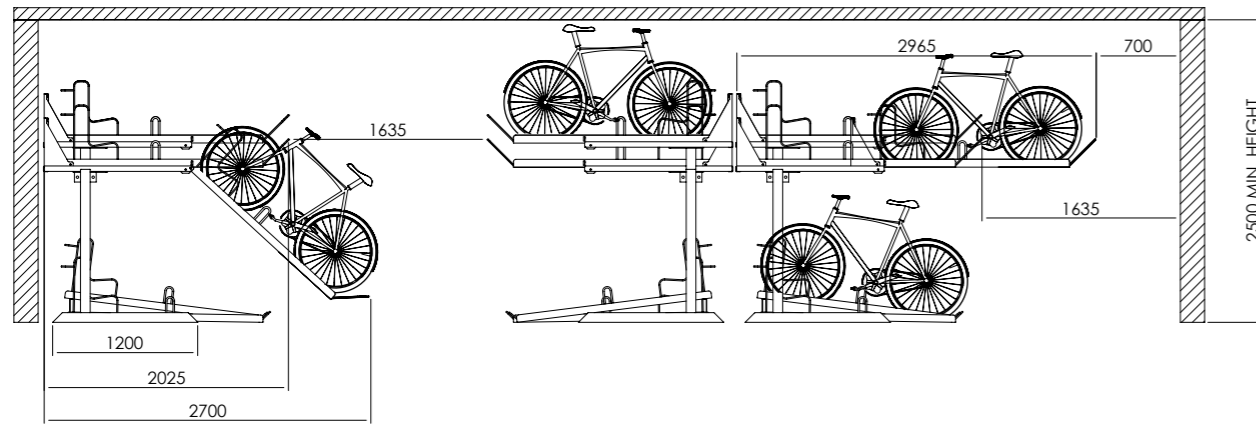

TOP

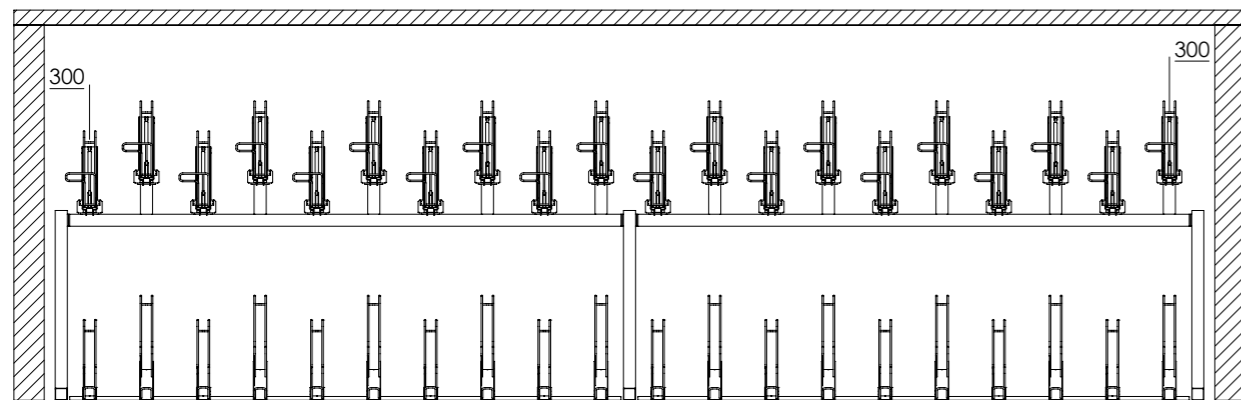

FRONT

**LAYOUT 1**

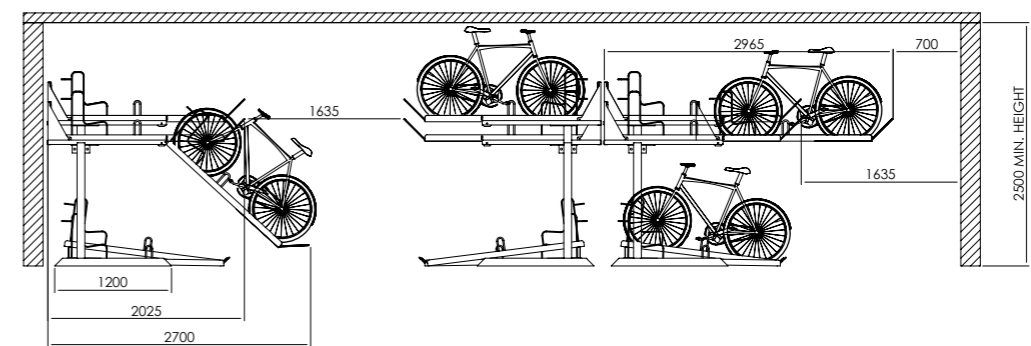
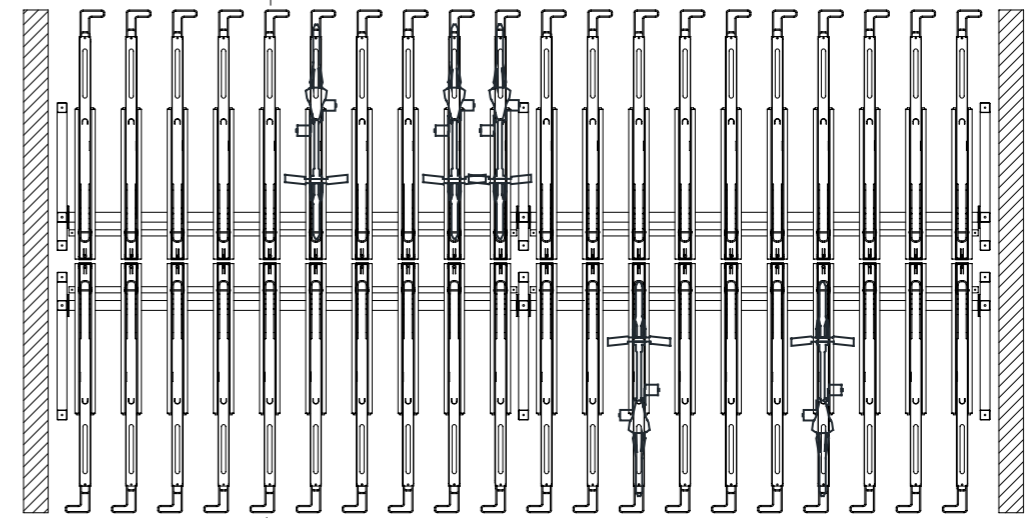
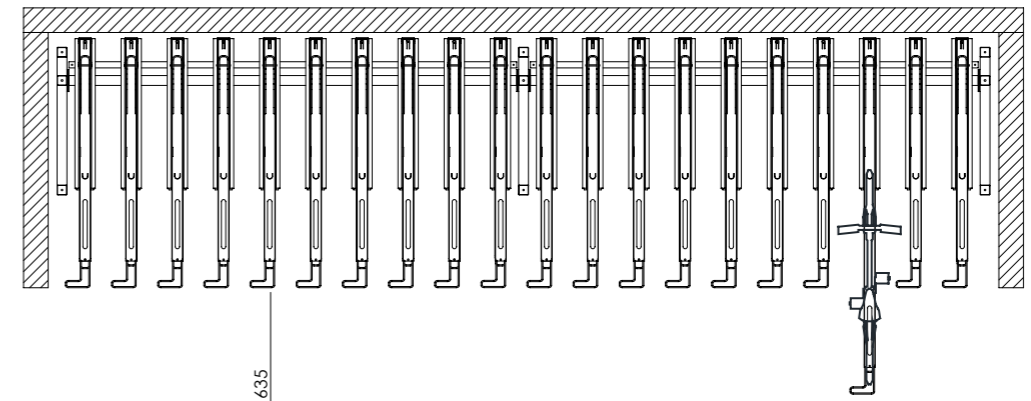

SIDE

## LAYOUT 2

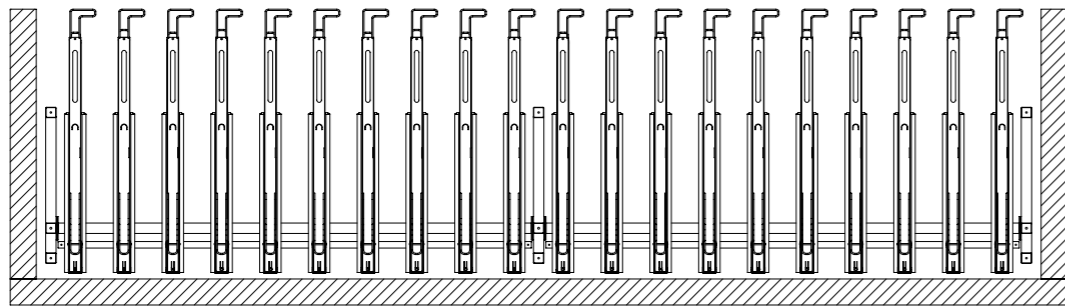
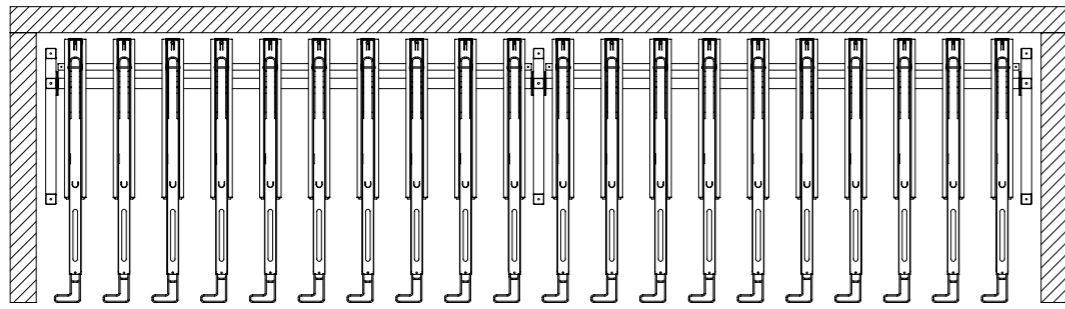

TOP

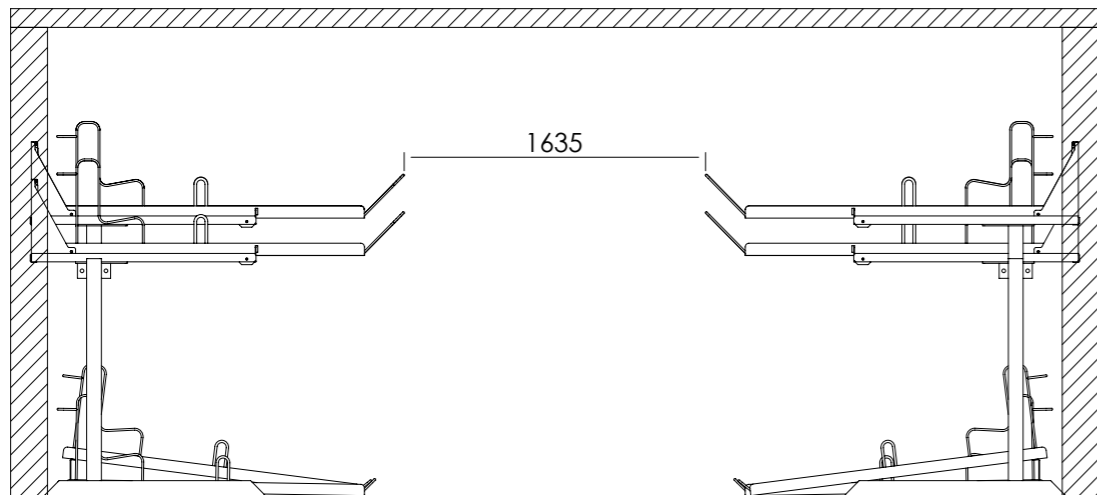

SIDE

## LAYOUT 3

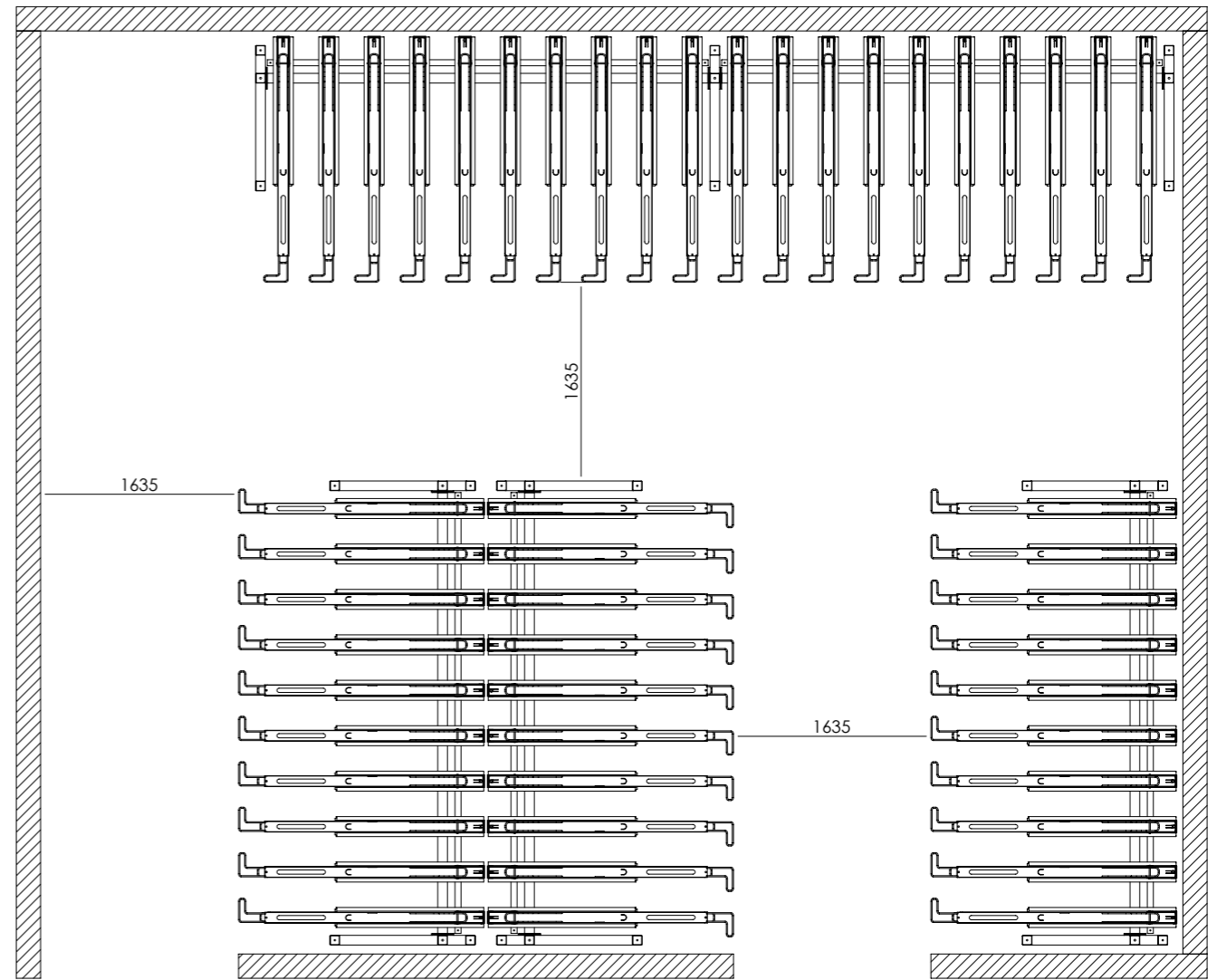

TOP

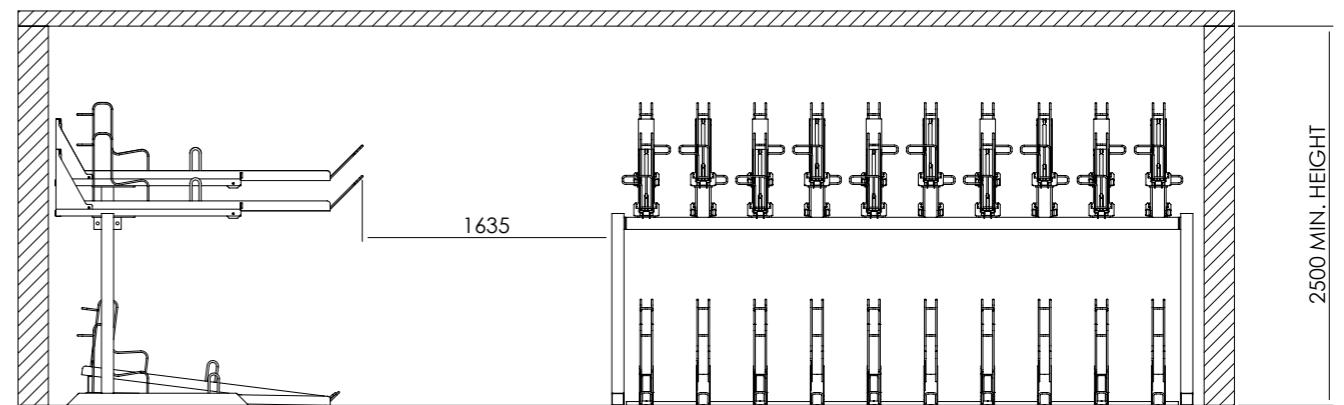

SIDE