

ROCKERPLAY

ROCKING HORSE

PROD CODE:	6060-011 (Ground Fix) 6060-811 (Bark Fix)
SIZE:	500 x 1000 x 2700
AGE RANGE:	5 – 10 years
FREE FALL HEIGHT:	1000 mm
FREE SPACE:	2000 x 1500 x 4342 mm
WEIGHT OF HEAVIEST PART	150 Kg
OVERALL WEIGHT OF UNIT	285 Kg

DELIVERY LIST

Part No.	Description	Qty
5114-005	MAJOR BODY ASSY.	1
4200-110	STANCHION ASSY.	2
5113-101	TIE BAR ASSY.	2
	FIXINGS PACK	1

SPECIFICATION

Manufactured from M.S. Sheet to BS 1449 Pt. 1 (1983) and from M.S. angle to BS 4360 (1986). Castings shall be grey cast iron grade 14/17 to BS 1452 (1977).

All metal parts will be protected with low lead powder paint (within the meaning of the Toy and Safety Regulations 1367 (1974) and the Pencil and Graphics Regulations.

INSTALLATION INSTRUCTIONS

1. Read instructions carefully before commencing erection of unit.
2. Do not tighten fastenings until unit is completely assembled.
3. Excavate foundations in accordance with details shown in foundation plan on page 5.
4. Attach 2 tie bars (C) between stanchions (B), using 4 off 3/4" BSW nuts (M) and M20 washers (N) as shown on page 2.
5. Place Stanchion/Tie Bar Assembly into prepared foundations so that each Stanchion stands on a standard red house brick. If necessary prop Stanchions to prevent movement.
6. Backfill foundations with approx 0.7 cubic metres of concrete and prevent use for 48 hours or until set.
7. Remove 10 Pentagon Head Screws from Under Body Panels leaving brackets attached to side panels.
8. Position Main Body Assembly Damper Unit so the rubber buffers point outwards and fix Stanchions (B) to Damper Unit using M16 x 120 High Tensile Bolts (J) with M16 Washer (L) and M16 Spring Washers (K) as shown on page 2.
9. Replace Under Body Panels using 10 Pentagon Head Screws.

ENSURE A GAP OF NO MORE THAN 6mm IS PRESENT BETWEEN UNDERBODY PANELS AND STANCHIONS.

Notes:

M8 bolts to be torqued to 18Nm (13lbf.)
M10 bolts to be torqued to 34Nm (25lbf)
M12 bolts to be torqued to 55Nm (40lbf)

All protruding screw threads to be peened over to remove sharp edges.

Lifting aid will be required when installing this piece of equipment.

Note:-Ensure all installation aids are removed before first use.

INSTALLATION INSTRUCTIONS

Attaching Tie Bars to Stanchions

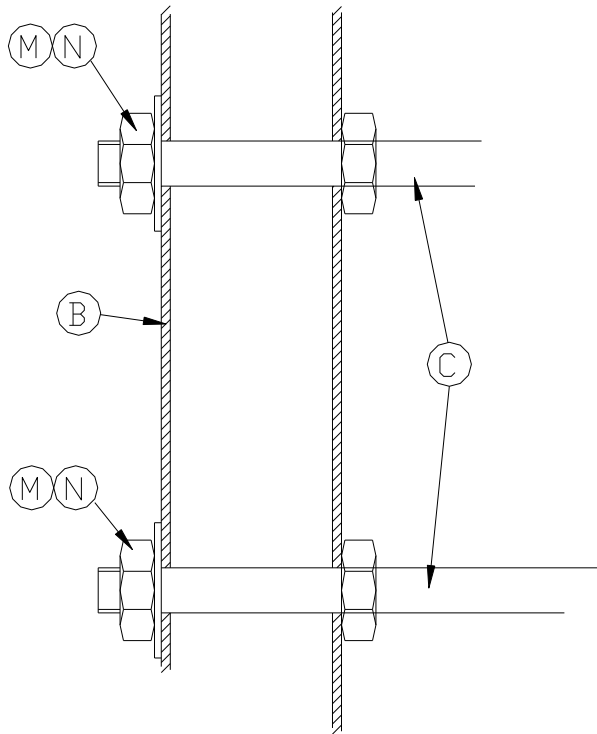

Attaching Main Body Assembly Damper Unit to Stanchions

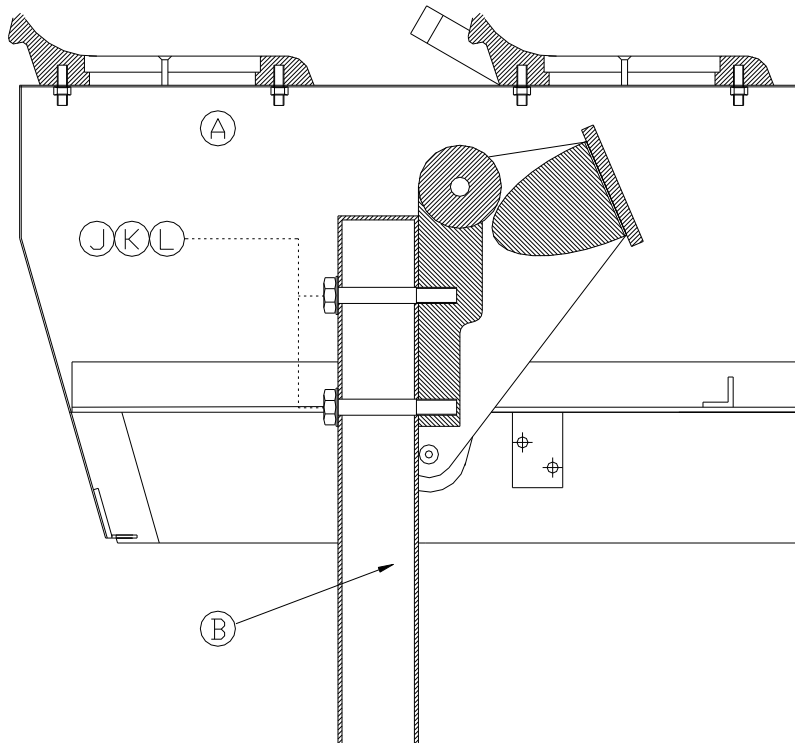

INSTALLATION INSTRUCTIONS

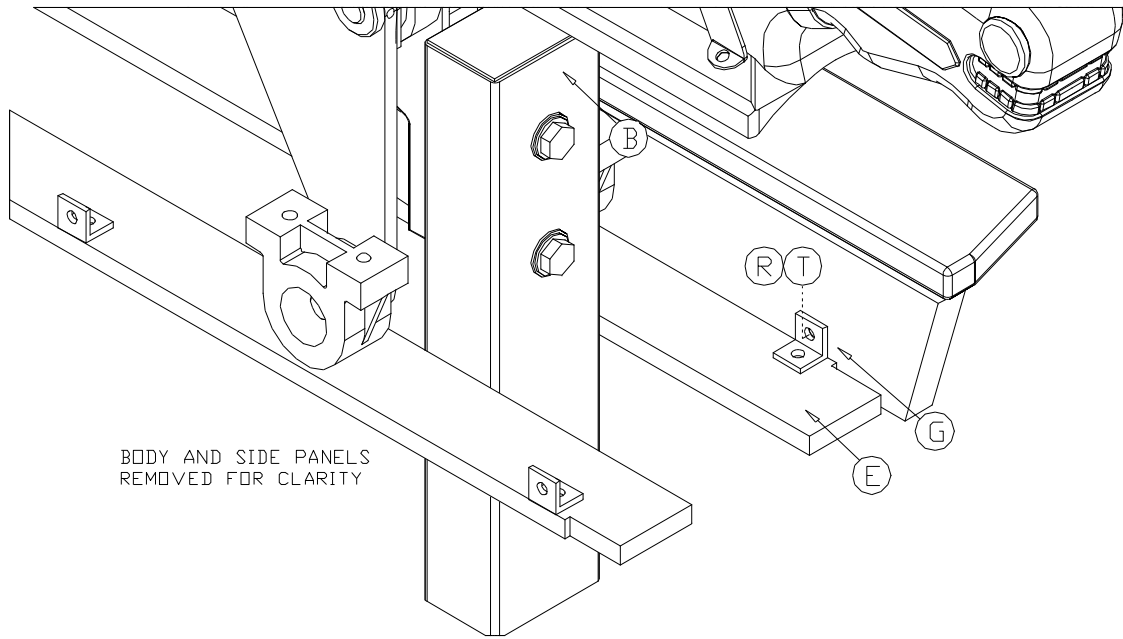

**ENSURE A GAP OF NO MORE THAN 6mm IS PRESENT BETWEEN
UNDERBODY PANELS AND STANCHIONS**

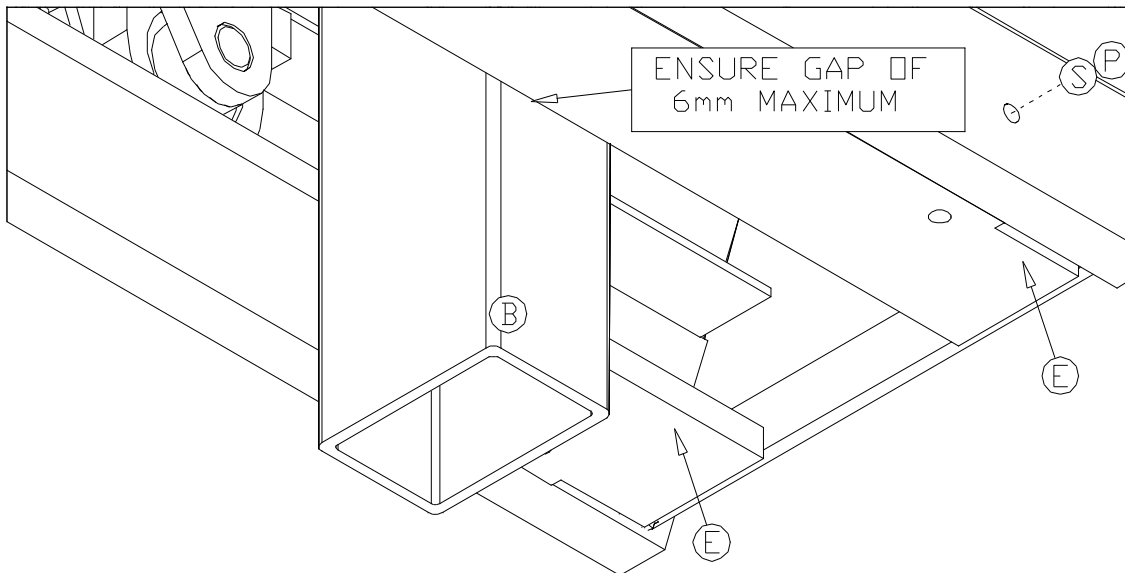

**VIEW FROM BELOW
STANCHION SECTIONED
FOR ILLUSTRATION ONLY**

FOUNDATION DETAILS

FSL=FINISHED SURFACE LEVEL

GROUND FIX

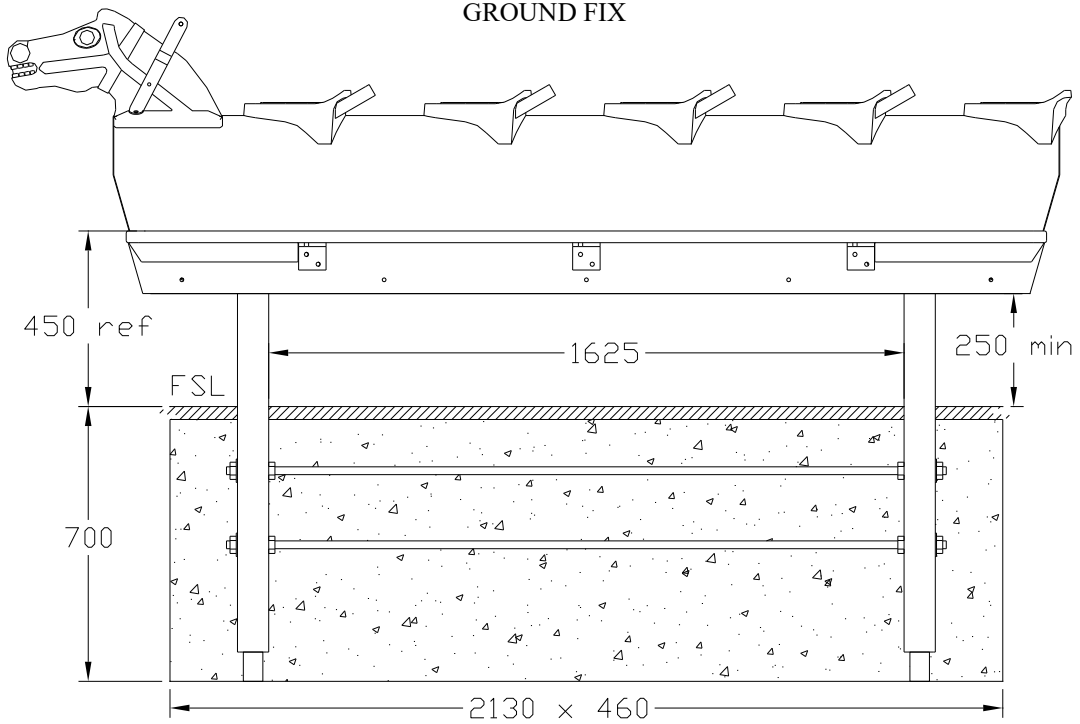

BARK FIX

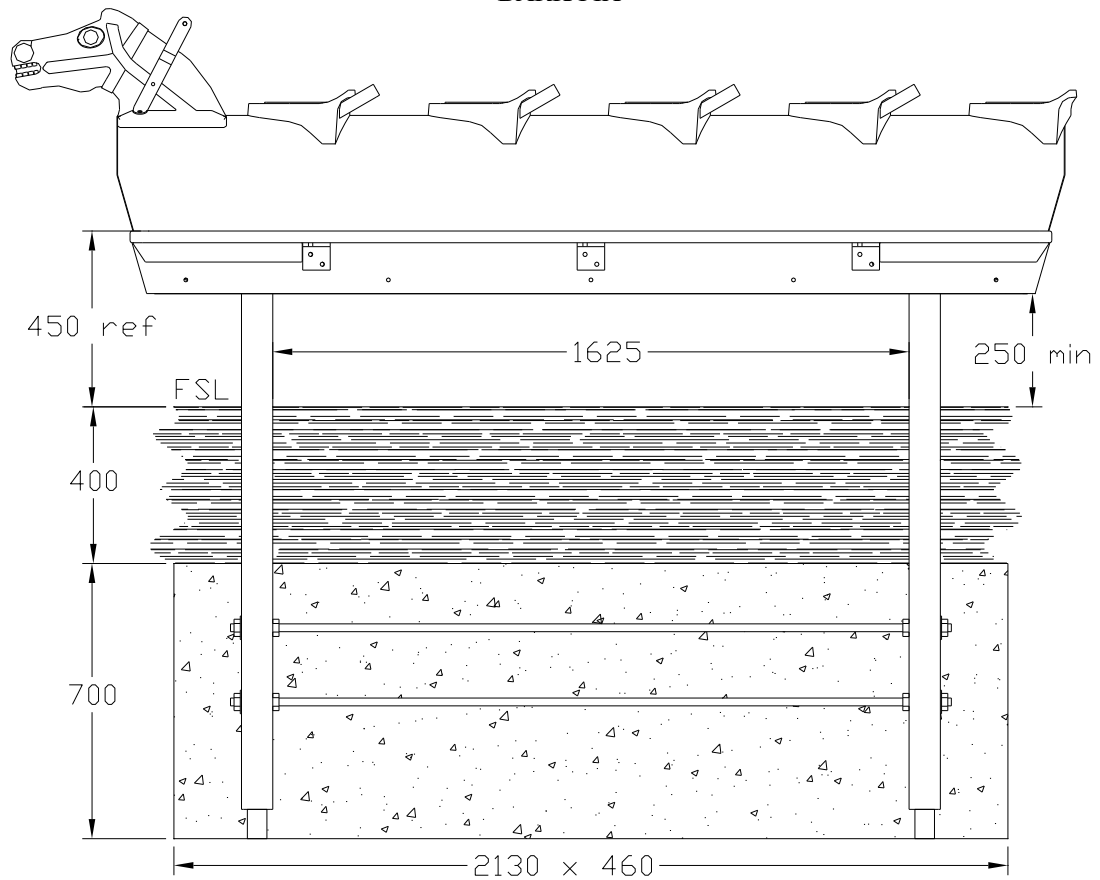

MINIMUM & FREE SPACE DETAIL

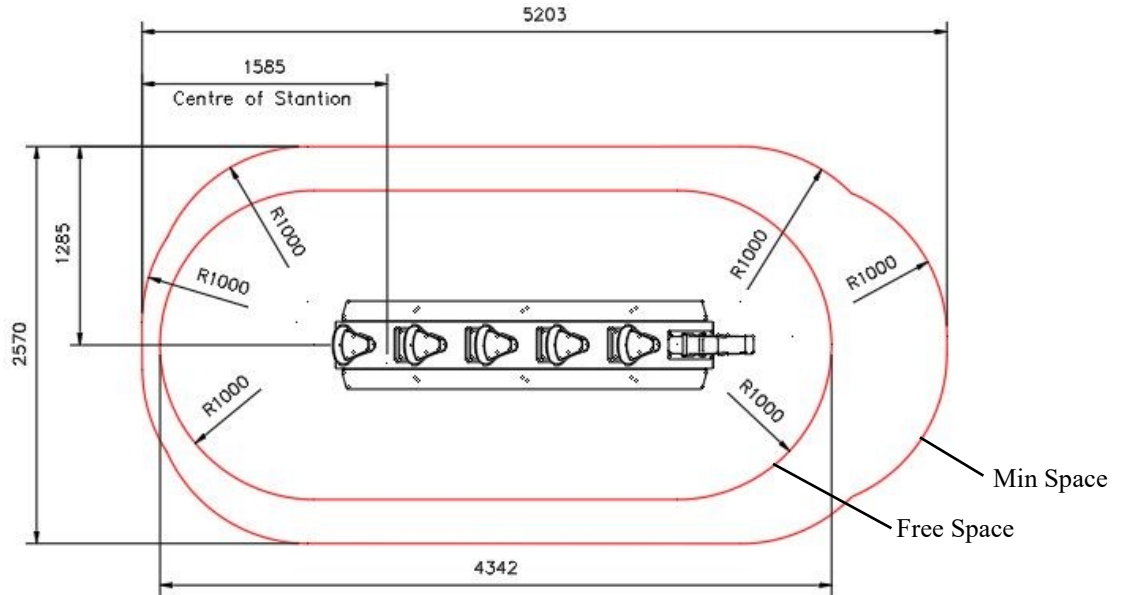

WETPOUR
FFH = 1000mm
13.0 sqm of Wetpour Area
14.0 Linear metres of wetpour edging

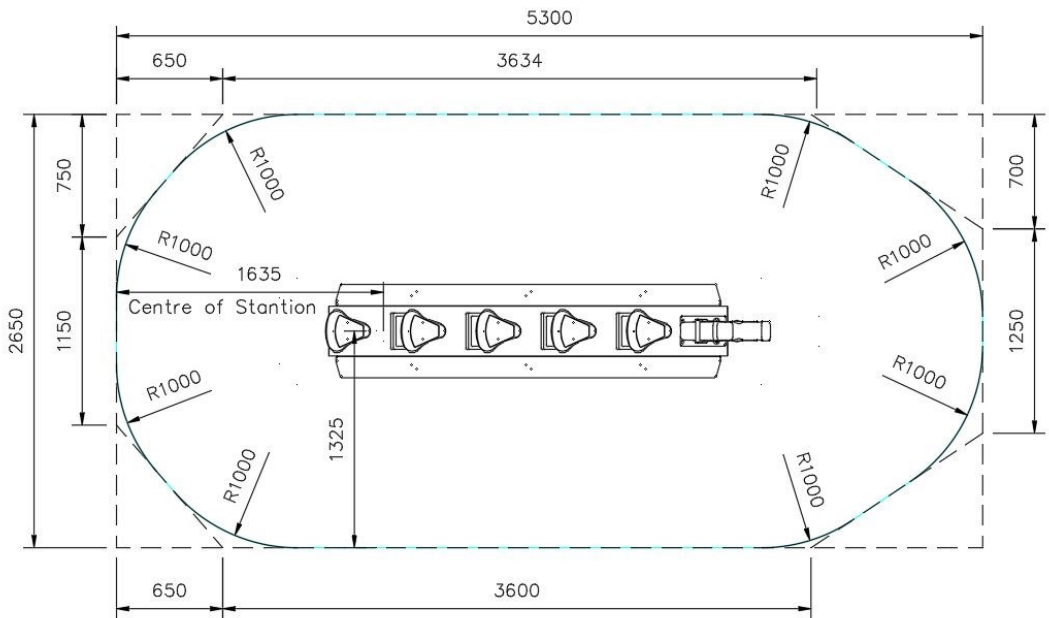

GRASS MATS
11 Grass Mats

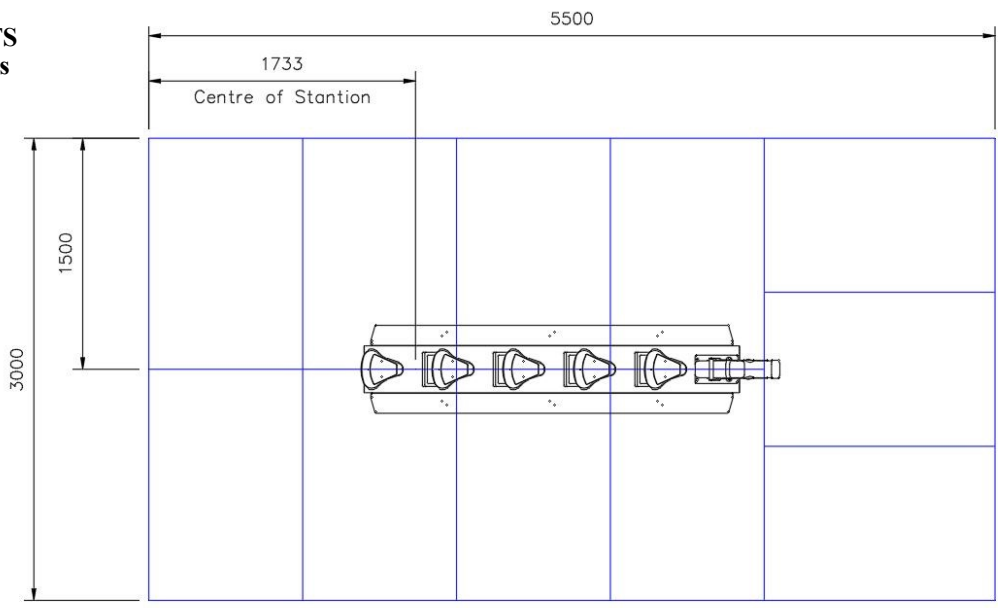

REF	QTY	DESCRIPTION	PART No
A	1	MAIN BODY ASSEMBLY	5114-005
B	2	STANCHION ASSEMBLY GROUND FIX	4200-110
C	2	TIE BAR ASSEMBLY	5113-101
D			
E	2	UNDERBODY PANELS *	3723-562
F			
G			
H			
J	4	M16 x 120 HIGH TENSILE BOLT	2185-096
K	4	M16 COIL SPRING WASHER	2212-205
L	4	M16 PLAIN WASHER	2212-511
M	4	M20 HEX NUT	2193-011
N	4	M20 WASHER	2215-512
P	10	M8 SAFETY FASTENER *	2177-001
Q	10	M8 x 25 BUTTON HEAD SCREW *	2176-152
R	10	M8 x 35 BUTTON HEAD SCREW *	2176-154
S	10	M10 WASHERS *	2214-009
T	20	M8 WASHERS *	2214-005
	2	M8 PENTAGONAL KEY	2372-003
		FOR BARK FIX REPLACE ITEM B WITH:	
	2	STANCHION ASSEMBLY BARK FIX	4200-111
		* ITEMS FITTED PRIOR TO DESPATCH	
	10	SIDE BRACKET *	3200-290
	2	DAMPER UNIT ASSEMBLY *	5114-052
	6	FOOTBOARD BRACKET *	3112-013
	5	SEAT INSERT *	3752-053
	1	SEAT WITHOUT HANDLE *	3712-226
	4	SEAT WITH HANDLE *	3712-225

Note:-All spare parts are available from Wicksteed Leisure on request.

For maintenance instructions see separate sheet.

	COMPILED BY:	APPD BY:	REV	10					
	NLG		ECN	1813					
	DATE:	DATE:	SIG.	MC					
	11-8-99		DATE.	19/01/21					

