

SPALDING seating

BENCH - PRODUCT DETAILS

Spalding bench without back

The Spalding bench consists of front to back bench slats, bolted onto a mild steel frame with tubular mild steel legs. Benches can be straight, curved or a combination of both. The bench is available with a choice of materials and finishes to suit your scheme and budget.

Materials

Slats - can be either FSC®-certified treated redwood, FSC®-certified hardwood or mild steel RHS.
Frames and legs - will be fully welded mild steel.

Finishes

Timber - as standard, will be supplied with a natural finish.
Stained finish is available on request.
Mild steel - as standard, will be supplied with a hot dip galvanised finish.
After galvanising, a polyester powder coated finish is available on request.

Options

Choose whether the bench is to be straight or curved, the bench lengths, curved bench radius, material, finishes and installation type.

Accessories

Optional armrests available on request.

Delivery

Depending on the size or complexity, the benches will be factory assembled and delivered to site fully assembled, for off loading and placing in position.



Street Design

Unit 35 Hayhill Industrial Estate Barrow upon Soar Leicestershire LE12 8LD
01509 815335 sdl@street-design.com www.street-design.com

UK Street Furniture Designers & Manufacturers



Spalding straight bench, in natural finish FSC®-certified hardwood slats with galvanised frame and legs



Spalding curved bench, in natural finish FSC®-certified treated redwood slats with galvanised frame and legs

Overall dimensions

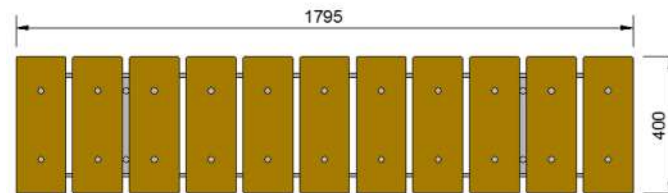
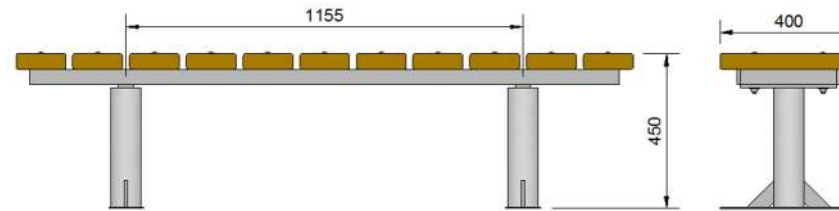

The standard Spalding straight bench will be 1795mm long. Other lengths can be supplied on request.

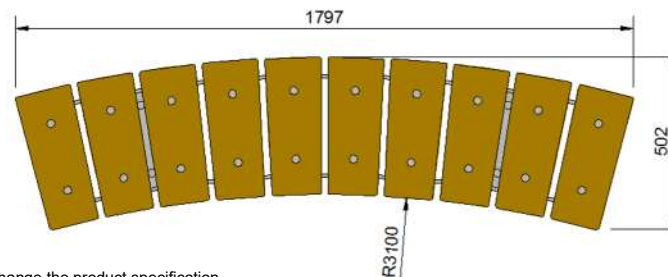

The standard Spalding curved bench will have an internal radius of 3100mm. Other radii can be supplied on request.

Installation options

Spalding straight and curved benches can be supplied for installation above or below finished ground level.

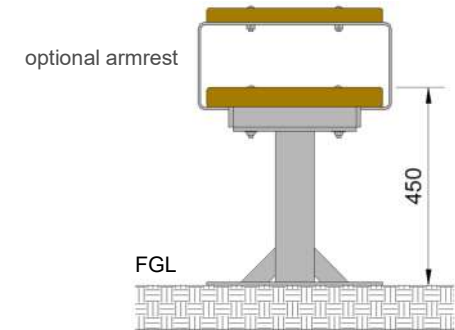

Above ground installation

The assembled Spalding bench will be secured to the finished ground level with suitable fixings for the surface type.

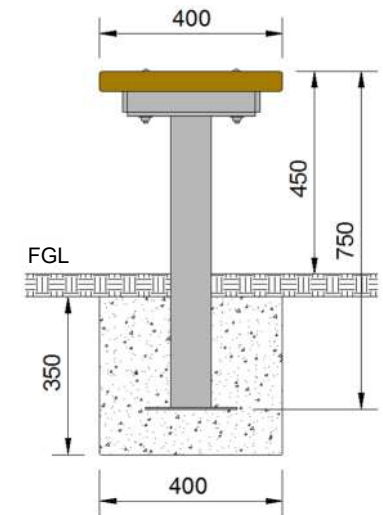

Below ground installation

The assembled Spalding bench will be set into concrete foundations 500x400x400mm deep.