

**CARACTERÍSTICAS / FEATURES**

**Material** hormigón petra 1  
**Acabado** decapado e hidrofugado  
**Dimensiones** l. 200, a. 60, h. 54 cm  
**Color** ver carta de colores  
**Fijación** mediante resina epoxy  
**Peso** 700 Kg  
**Bulto** 200 x 80 x 70 cm  
**Peso bulto** 715 Kg

**Material** precast concrete petra 1  
**Finish** scaled and waterproofed  
**Dimensions** l. 200, a. 60, h. 54 cm  
**Colour** see colour catalogue  
**Fixing** anchored with epoxy resin  
**Weight** 700 Kg  
**Package** 200 x 80 x 70 cm  
**Weight package** 715 Kg

diseñador / design: Oriol Pardo

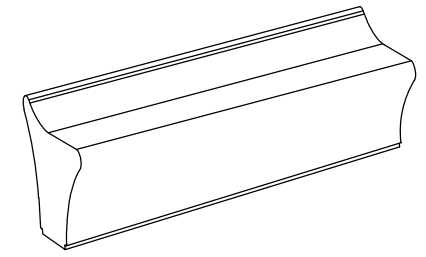
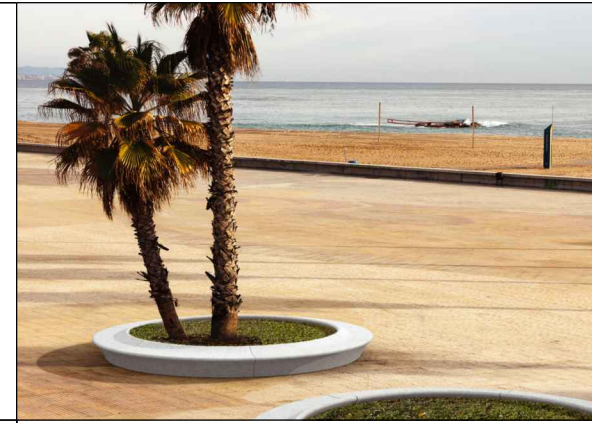

**GEOMETRIA / GEOMETRY**

- A** barra corrugada / corrugated rod
- B** casquillo roscado / thread sleeve
- C** cáncamo / eyebolt
- D** tapa / stopper

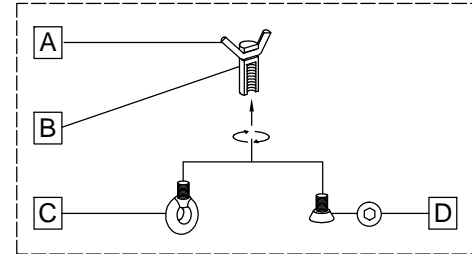

SISTEMA DE ELEVACIÓN / LIFTING SYSTEM

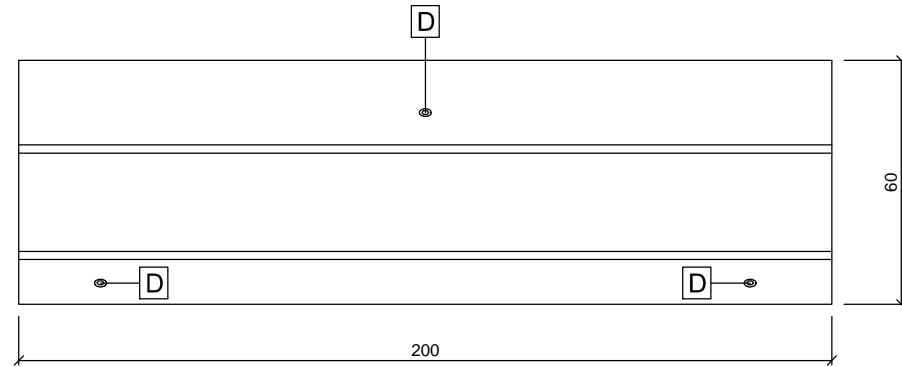

VISTA INFERIOR / BOTTOM VIEW

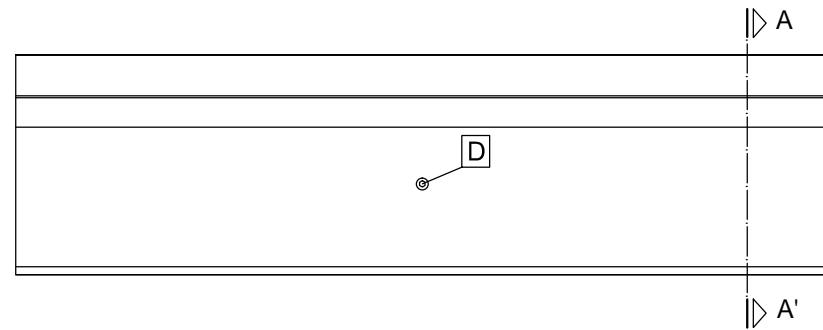

ALZADO / FRONT VIEW

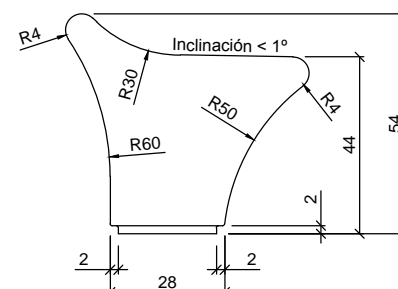

PERFIL / PROFIL VIEW

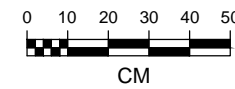

**MANIPULACIÓN E INSTALACIÓN / HANDLING AND INSTALLATION**

- 1** extraer tapa / extract stopper
- 2** enroscar cáncamo / thread the eyebolt

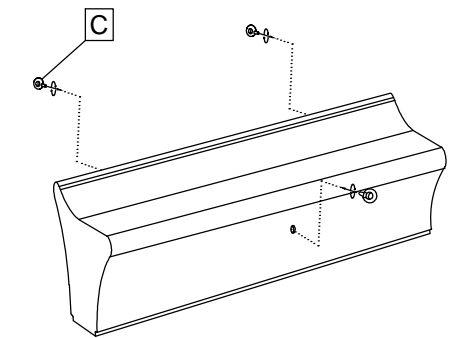
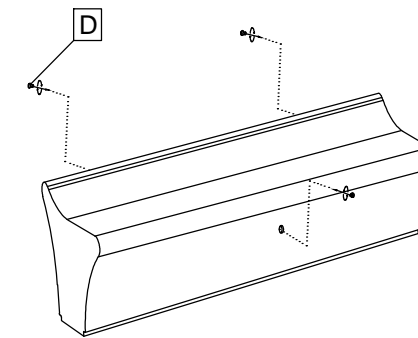

- 3** verter resina epoxy / pour resin epoxy
- 4** elevar e instalar / lift and install

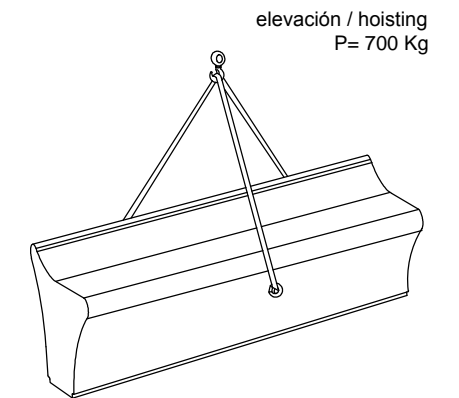
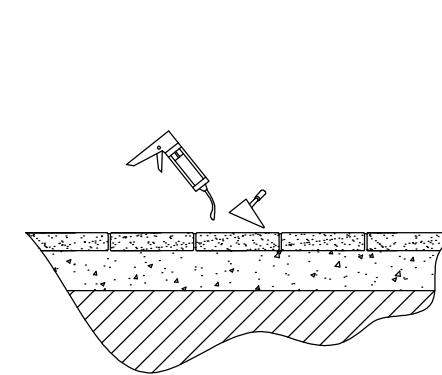

**ESPECIFICACIONES / SPECIFICATIONS**



Free phone: 0808 101 1590  
 email: sales@publicspaces.eu  
 Web: www.publicspaces.eu

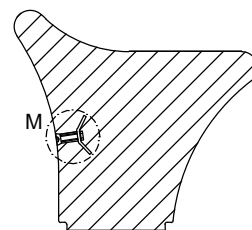

SECCIÓN A-A' / SECTION A-A'

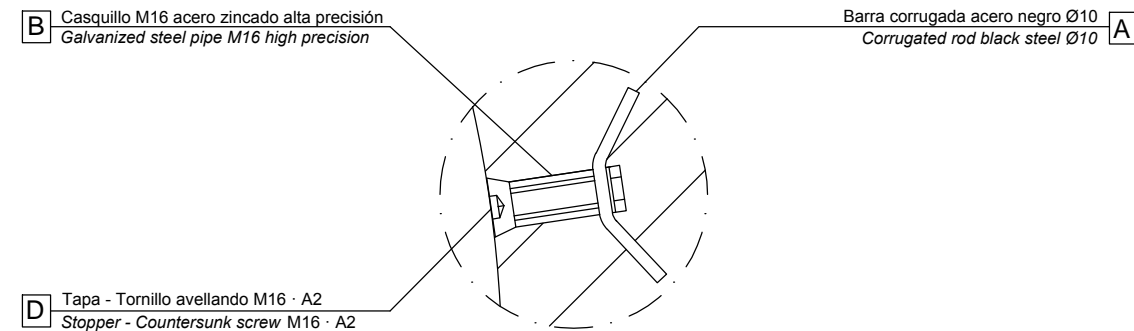

DETALLE M / DETAIL M

**CARACTERÍSTICAS / FEATURES**

**Material** hormigón petra 1  
**Acabado** decapado e hidrofugado  
**Dimensiones** l. 230, a. 83, h. 54 cm - R170 < 60°  
**Color** ver carta de colores  
**Fijación** mediante resina epoxy  
**Peso** 880 Kg  
**Bulto** 240 x 100 x 70 cm  
**Peso bulto** 895 Kg

**Material** precast concrete petra 1  
**Finish** scaled and waterproofed  
**Dimensions** l. 230, a. 83, h. 54 cm - R170 < 60°  
**Colour** see colour catalogue  
**Fixing** anchored with epoxy resin  
**Weight** 880 Kg  
**Package** 240 x 100 x 70 cm  
**Weight package** 895 Kg

diseñador / design: Oriol Pardo

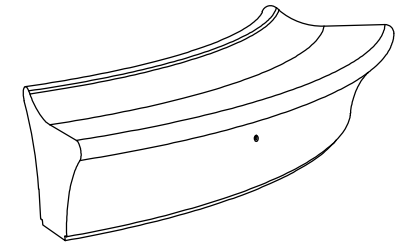

**GEOMETRIA / GEOMETRY**

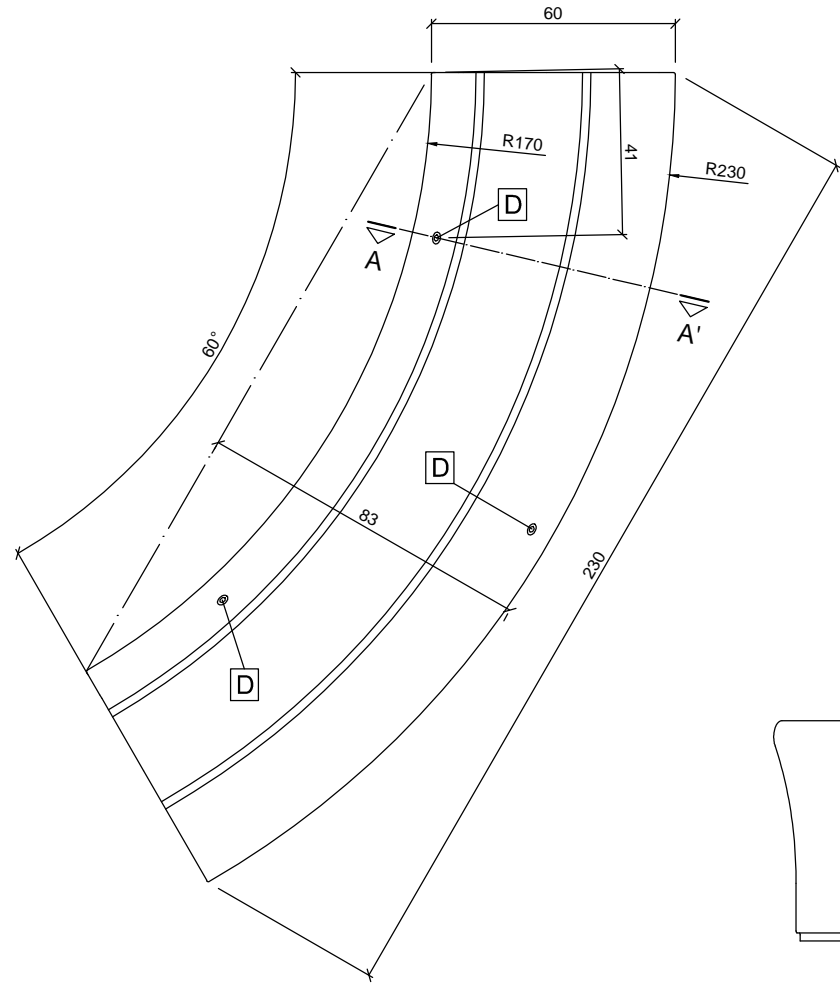

- A** barra corrugada / corrugated rod
- B** casquillo roscado / thread sleeve
- C** cáncamo / eyebolt
- D** tapa / stopper

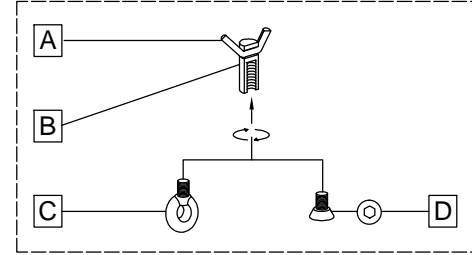

SISTEMA DE ELEVACIÓN / LIFTING SYSTEM

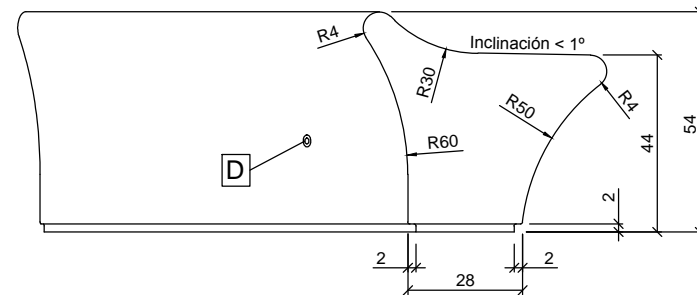

ALZADO / FRONT VIEW

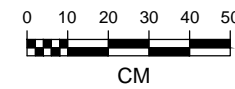

**MANIPULACIÓN E INSTALACIÓN / HANDLING AND INSTALLATION**

**1** extraer tapa / extract stopper

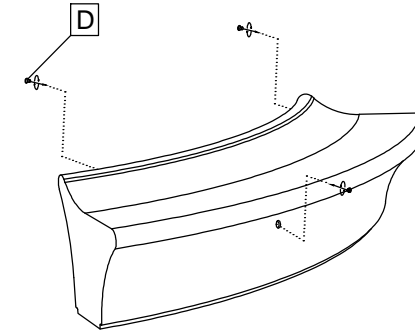

**2** enroscar cáncamo / thread the eyebolt

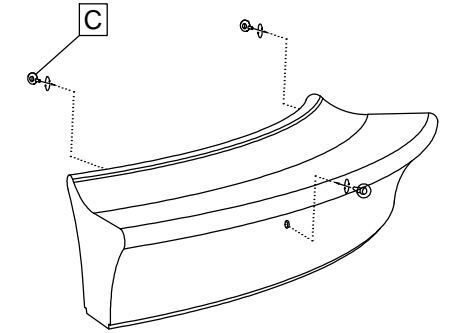

**3** verter resina epoxy / pour resin epoxy

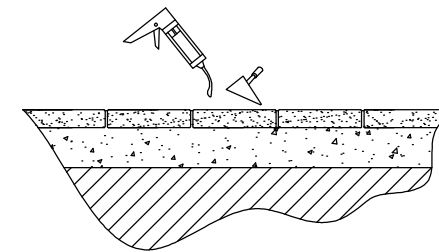

**4** elevar e instalar / lift and install

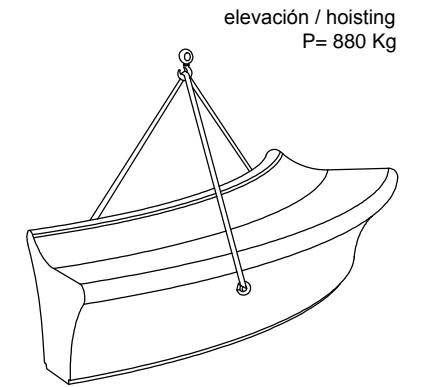

**ESPECIFICACIONES / SPECIFICATIONS**

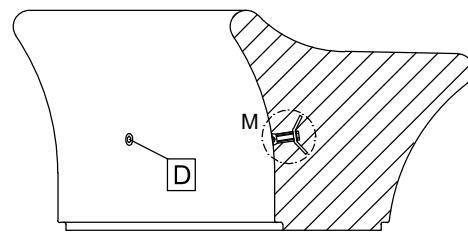

SECCIÓN A-A' / SECTION A-A'

**B** Casquillo M16 acero zincado alta precisión  
Galvanized steel pipe M16 high precision

Barra corrugada acero negro Ø10 **A**  
Corrugated rod black steel Ø10

**D** Tapa - Tornillo avellando M16 · A2  
Stopper - Countersunk screw M16 · A2

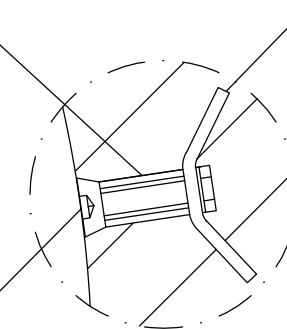

DETALLE M / DETAIL M

## CARACTERÍSTICAS / FEATURES

<b>Material</b>	hormigón petra 1
<b>Acabado</b>	decapado e hidrofugado
<b>Dimensiones</b>	l. 230, a. 83, h. 54 cm - R170 < 60°
<b>Color</b>	ver carta de colores
<b>Fijación</b>	mediante resina epoxy
<b>Peso</b>	900 Kg
<b>Bulto</b>	240 x 100 x 70 cm
<b>Peso bulto</b>	915 Kg

<b>Material</b>	precast concrete petra 1
<b>Finish</b>	scaled and waterproofed
<b>Dimensions</b>	l. 230, a. 83, h. 54 cm - R170 < 60°
<b>Colour</b>	see colour catalogue
<b>Fixing</b>	anchored with epoxy resin
<b>Weight</b>	900 Kg
<b>Package</b>	240 x 100 x 70 cm
<b>Weight package</b>	915 Kg

diseñador / design: Oriol Pardo

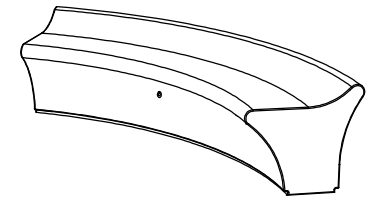

## GEOMETRIA / GEOMETRY

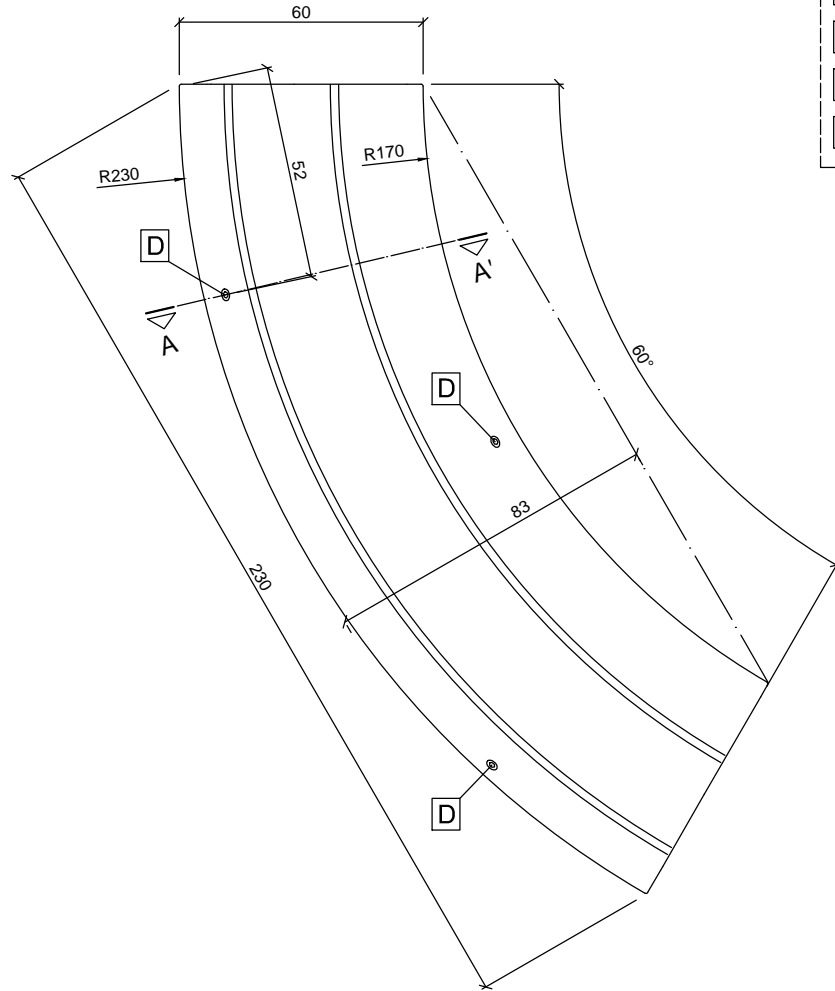

VISTA INFERIOR / BOTTOM VIEW

- A** barra corrugada / corrugated rod
- B** casquillo roscado / thread sleeve
- C** cáncamo / eyebolt
- D** tapa / stopper

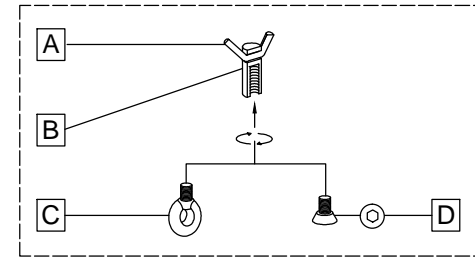

SISTEMA DE ELEVACIÓN / LIFTING SYSTEM

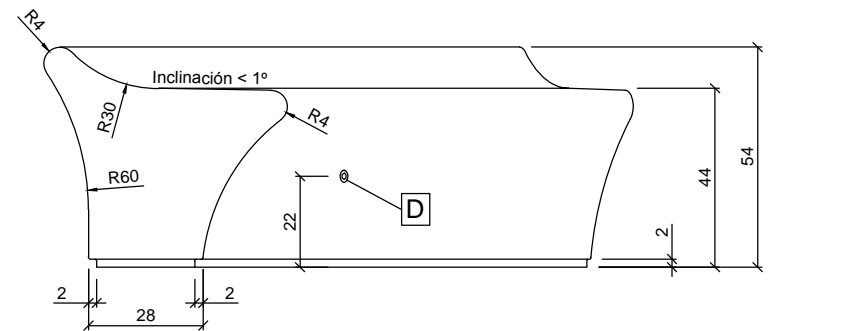

ALZADO / FRONT VIEW

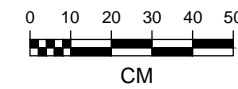

## MANIPULACIÓN E INSTALACIÓN / HANDLING AND INSTALLATION

**1** extraer tapa / extract stopper

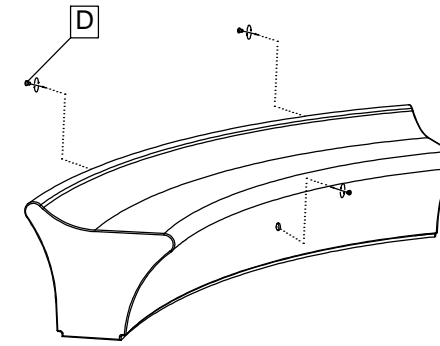

**2** enroscar cáncamo / thread the eyebolt

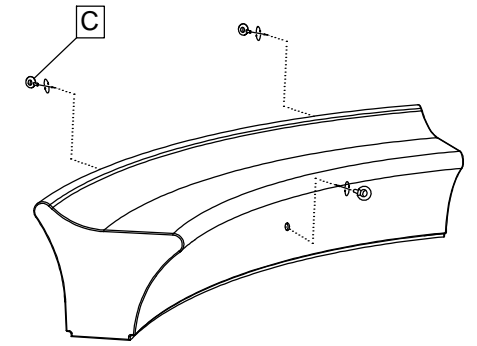

**3** verter resina epoxy / pour resin epoxy

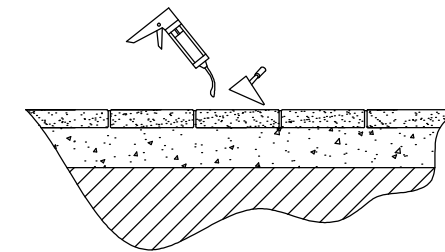

**4** elevar e instalar / lift and install

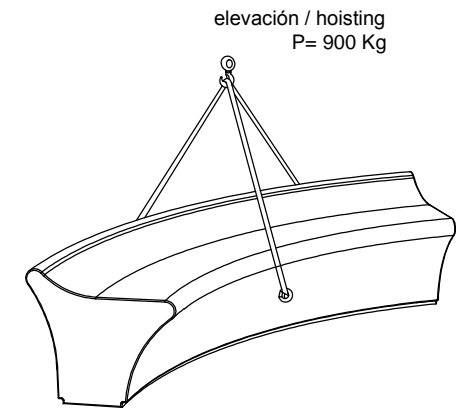

## ESPECIFICACIONES / SPECIFICATIONS

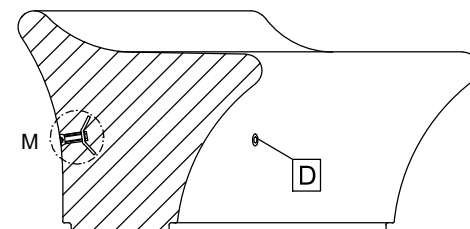

SECCIÓN A-A' / SECTION A-A'

**B** Casquillo M16 acero zincado alta precisión  
Galvanized steel pipe M16 high precision

Barra corrugada acero negro Ø10 **A**  
Corrugated rod black steel Ø10

**D** Tapa - Tornillo avellando M16 · A2  
Stopper - Countersunk screw M16 · A2

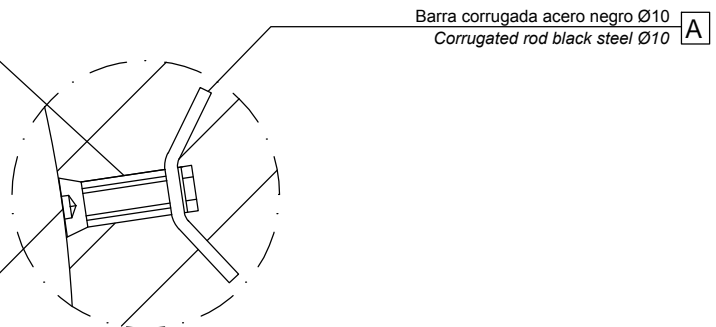

DETALLE M / DETAIL M