

design
make
play

SutcliffePlay

Waggon Lane
Upton Pontefract
West Yorkshire WF9 1JS
Telephone +44 (0) 1977 653200
Facsimile +44 (0) 1977 653222
info@sutcliffeplay.co.uk
www.sutcliffeplay.co.uk

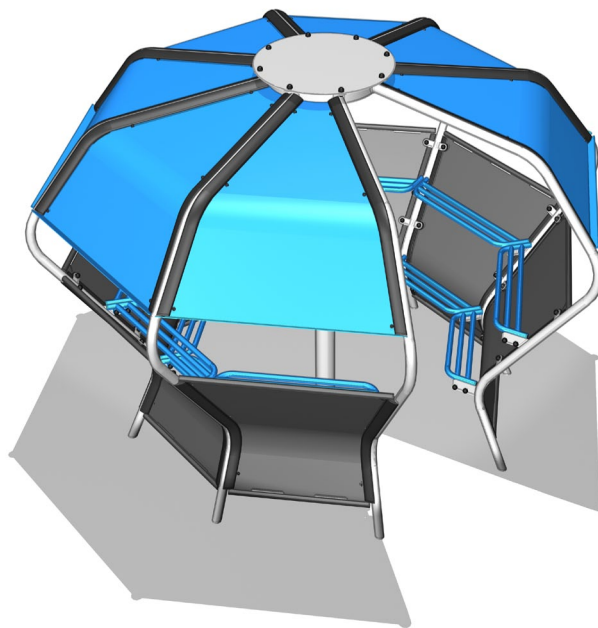

Pod Shelter

Installation Instructions

YOU070

YOU070





Pod Shelter Installation Instructions

design
make
play
SutcliffePlay

- 1 Read all instructions carefully before starting assembly.
- 2 Check using the Parts List and Fixing Kit List that none of the components are missing. If any parts are missing contact our Sales Office.
- 3 Plan the final position of the Pod ensuring that there is sufficient space. See the Ground Plan for recommended circulation space.
- 4 Excavate the foundation holes in accordance with the Ground Plan. The Pod is designed to be installed onto a level site.
- 5 Erect the Central Post into its foundation hole. There are 3 types of Outer Legs, a Right Hand Leg, a Left Hand Leg and Center Legs, follow the instructions to ensure the Outer Legs are positioned correctly.
- 6 All fixing positions incorporate a special Stepped Washer (DZS009). Ensure that these are fitted the correct way round with the shoulder to the outside, so that the Cover (DZS005) will snap into place when the fixings have been tightened.
- 7 Loosely fix the Outer Legs to the Central Post, then the Roof and Side Panels to the Outer Legs. Do not fully tighten any of the fixings until all the Panels have been fitted, this will allow the Outer Legs to adjust to their correct orientation.
- 8 Finally fit the Seats, tighten all the fixings and tap the Covers (DZS005) into place using a soft faced hammer.
- 9 Fill the foundation holes to the required depth with concrete.
- 10 Do not allow the equipment to be used until the concrete has set (2 - 3 days).
- 11 Follow the maintenance instructions supplied.

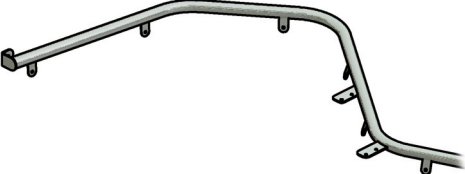
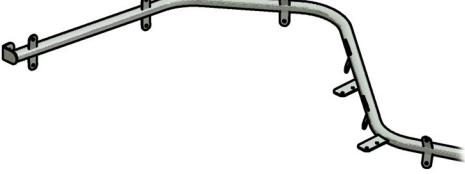
During installation care must be taken to prevent hazards to children.
Extra care should be taken if conditions are abnormal.

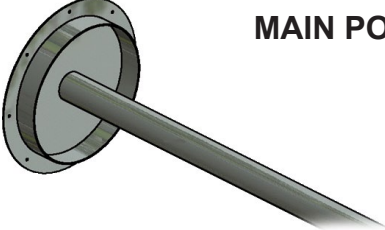
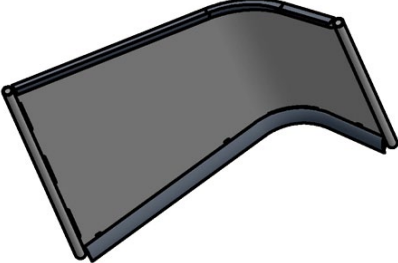
Pod Shelter YOU070 Parts List (colours may vary)

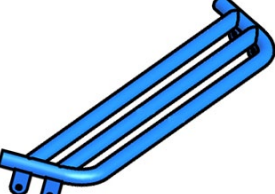
ILLUSTRATION	CODE	DESCRIPTION	QTY
	YOA045	LH OUTER LEG	1
	YOA050	MIDDLE OUTER LEG	6
	YOA055	RH OUTER LEG	1
 <p style="text-align: center;">MAIN POST ASSY</p>	HSS860 YOA011P YOA105 WSR070	M20 BOLTS MAIN POST GRND FIXING M20 WASHERS	4 1 1 4
	YOA044	SIDE PANEL ASSY	7
	YOA034	ROOF PANEL ASSY	7
	YOA060	LOWER SEAT RAIL	7
	YOA065	UPPER SEAT RAIL	7

Pod Shelter YOU070F Fixing List

ILLUSTRATION	CODE	DESCRIPTION	QTY
	DZS005	M10 NUT COVER	184
	DZS009	M10 COVER WASHER	184
	FIX159	M10 x 40 SECURITY SCREW	94
	FIX195	FIXING TOOL	1
	HSS510	M10 x 30 HEX HEAD SCREW	21
	HSS512	M10 x 35 HEX HEAD SCREW	29
	LKN320	M10 NYLOC NUT	144
	WSR040	M10 PLAIN WASHER	94
	YOS022	BRACKET SPACERS	94

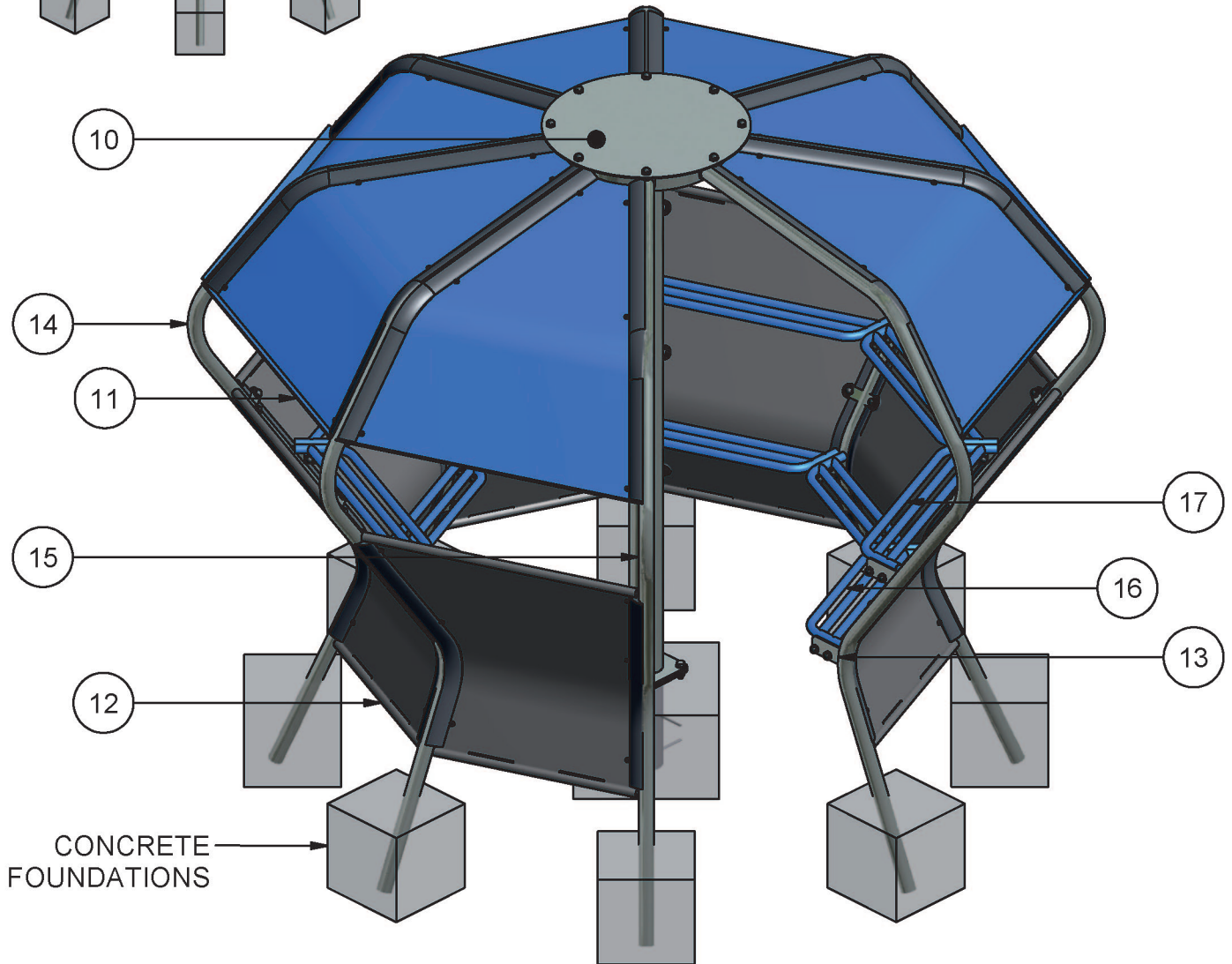
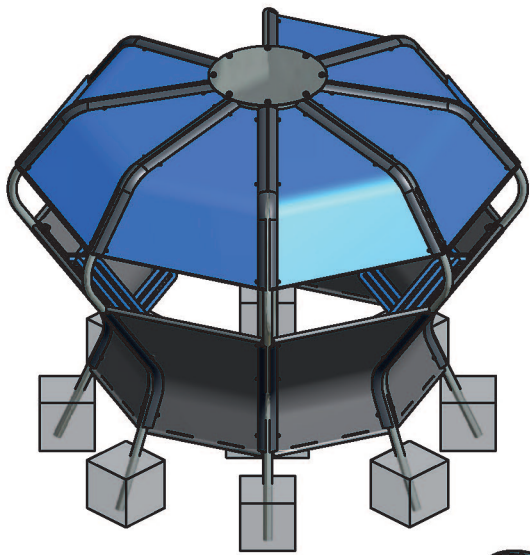

FIXING LIST			
ITEM	STOCK CODE	DESCRIPTION	QTY
10	YOA011P	CENTRAL POST ASSY ON PLATES	1
11	YOA034B	ROOF PANEL ASSY	7
12	YOA044GY	SIDE PANEL ASSY	7
13	YOA045	YOUTH SHELTER LH LEG	1
14	YOA050	YOUTH SHELTER MIDDLE LEG	6
15	YOA055	YOUTH SHELTER RH LEG	1
16	YOA060	LOWER SEAT RAIL	7
17	YOA065	UPPER SEAT RAIL	7

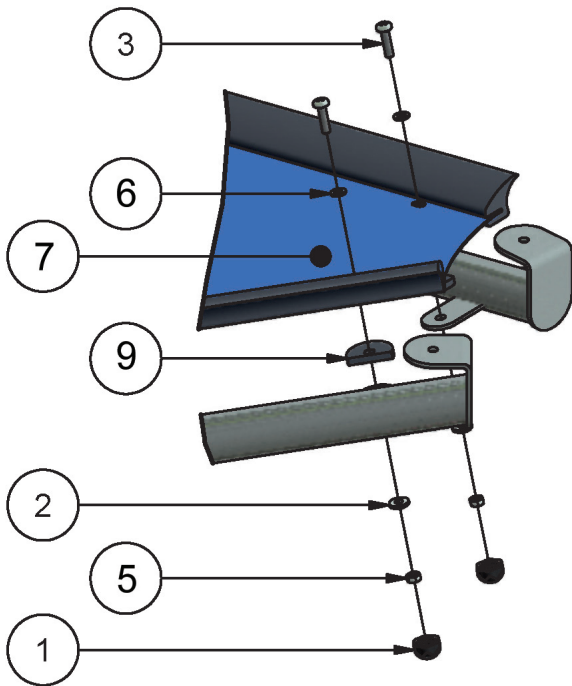
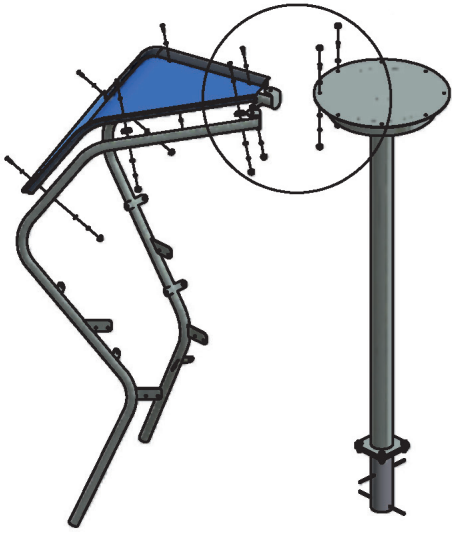

FIXINGS REQUIRED FOR
ATTACHING ROOF PANELS
TO THE LEGS

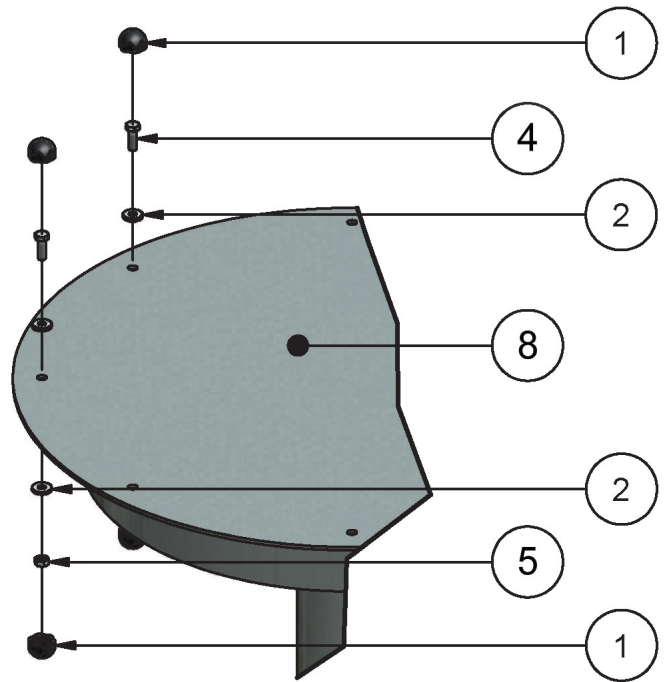

FIXINGS REQUIRED FOR
ATTACHING LEGS TO THE
CENTRAL POST.

FIXING LIST			
ITEM	STOCK CODE	DESCRIPTION	QTY
1	DZS005	M10 NUT COVER	164
2	DZS009	M10 COVER WASHER	164
3	FIX159	M10 x 40 SECURITY SCREW	84
4	HSS510	M10 x 30 HEX SET SCREW	16
5	LKN320	M10 NYLOC NUT	124
6	WSR040	M10 PLAIN WASHER	84
7	YOA034B	ROOF PANEL ASSY	7
8	YOA011P	CENTRAL POST ASSY	1
9	YOS022	BRACKET SPACERS	84

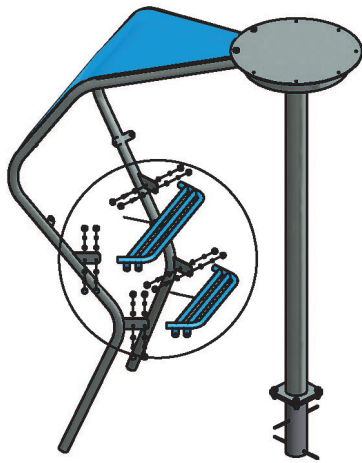

USE ITEM 4 WHEN FITTING 2 SEATS TO A MIDDLE LEG. USE ITEM 3 WHEN FITTING A SEAT TO AN END LEG.

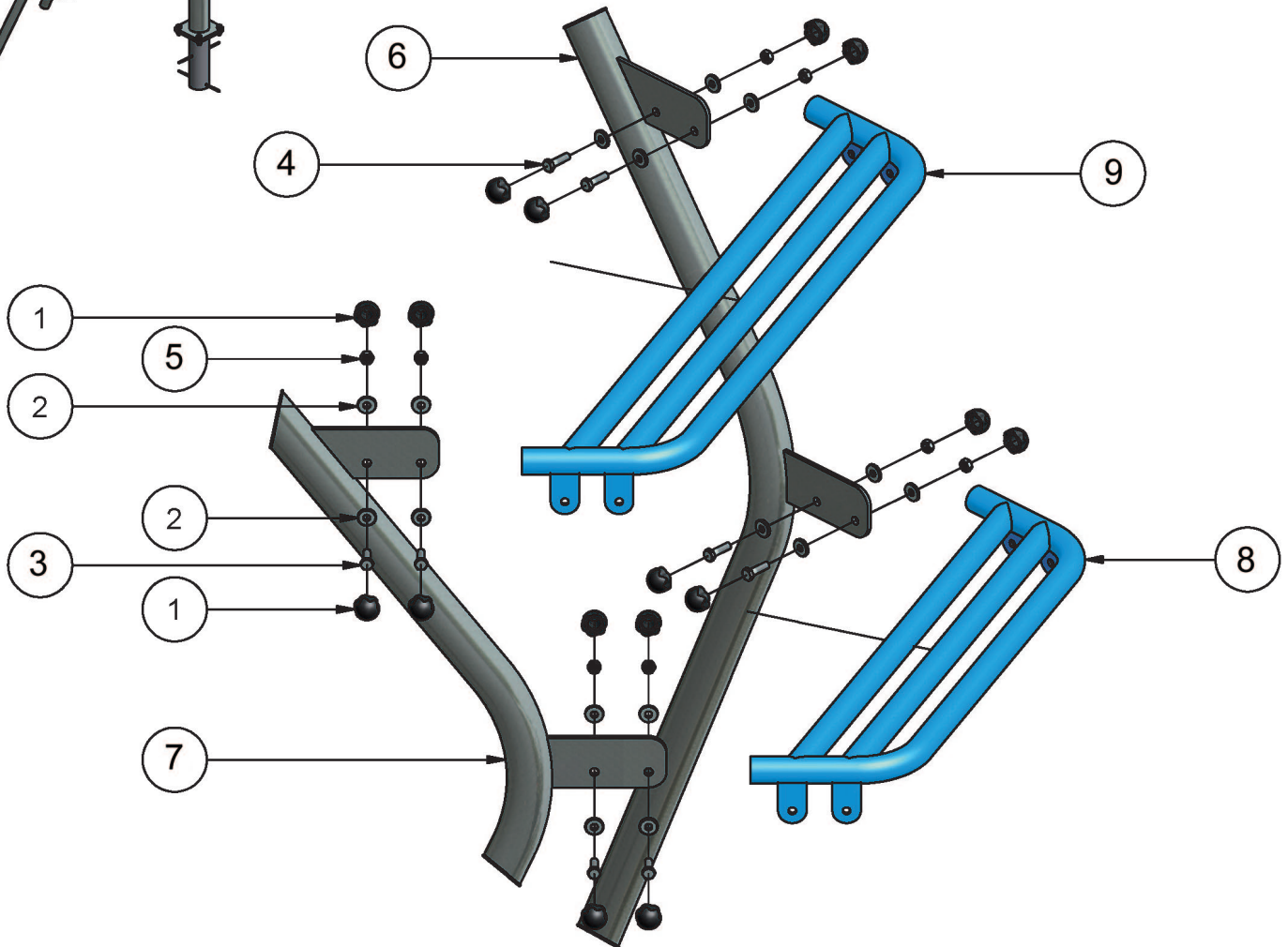

FIXING LIST			
ITEM	STOCK CODE	DESCRIPTION	QTY
1	DZS005	M10 NUT COVER	164
2	DZS009	M10 COVER WASHER	164
3	HSS510	M10 x 30 HEX SET SCREW	16
4	HSS512	M10 x 35 HEX SET SCREW	24
5	LKN320	M10 NYLOC NUT	124
6	YOA050 / 250	YOUTH SHELTER MIDDLE LEG	6
7	YOA055 / 255	YOUTH SHELTER RH LEG	1
8	YOA060	LOWER SEAT RAIL	7
9	YOA065	UPPER SEAT RAIL	7

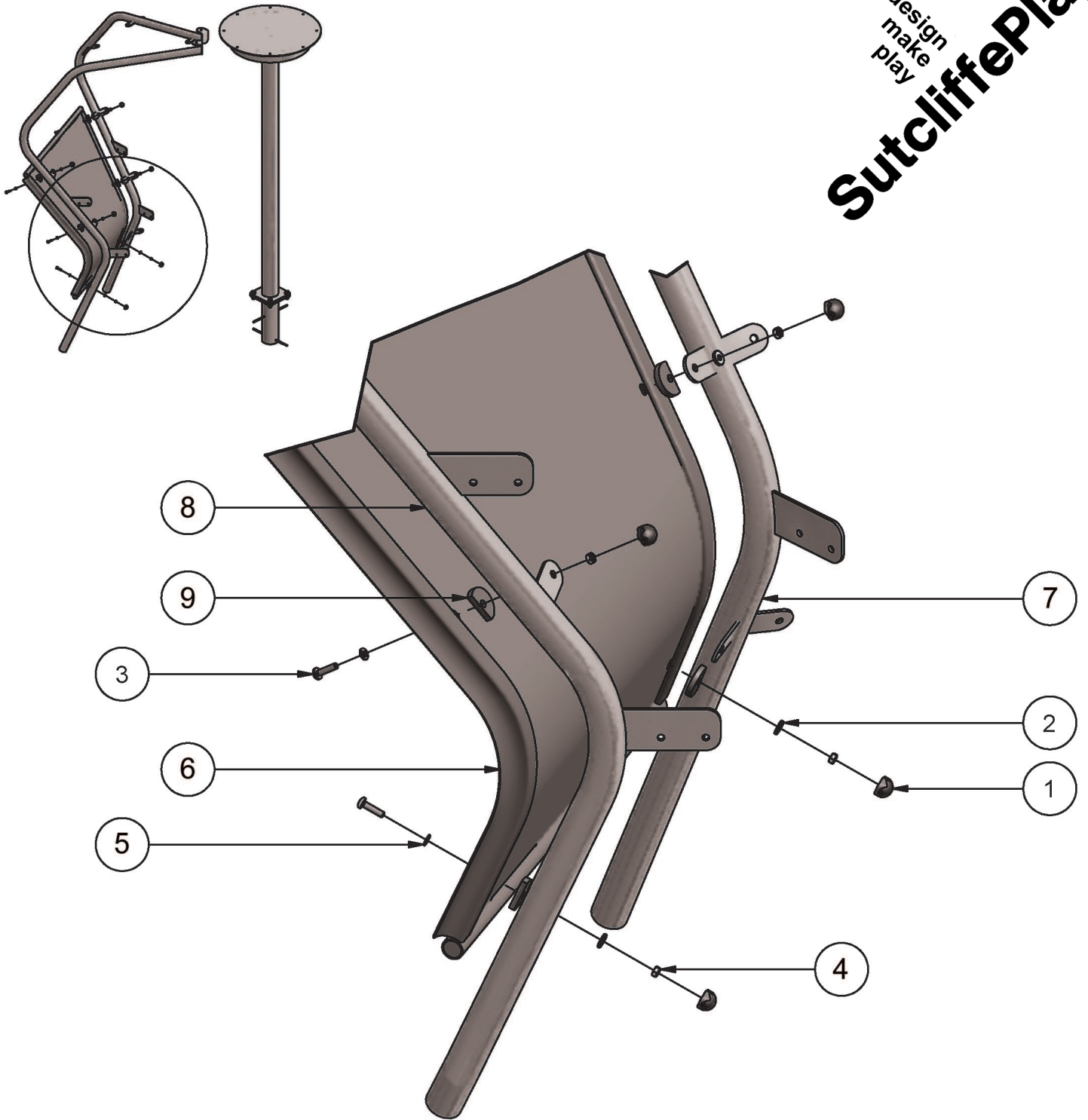

FIXING LIST			
ITEM	STOCK CODE	DESCRIPTION	QTY
1	DZS005	M10 NUT COVER	164
2	DZS009	M10 COVER WASHER	164
3	FIX159	M10 x 40 SECURITY SCREW	84
4	LKN320	M10 NYLOC NUT	124
5	WSR040	M10 PLAIN WASHER	84
6	YOA044GY	SIDE PANEL ASSY	7
7	YOA050	YOUTH SHELTER MIDDLE LEG	6
8	YOA055	YOUTH SHELTER RH LEG	1
9	YOS022	BRACKET SPACERS	84

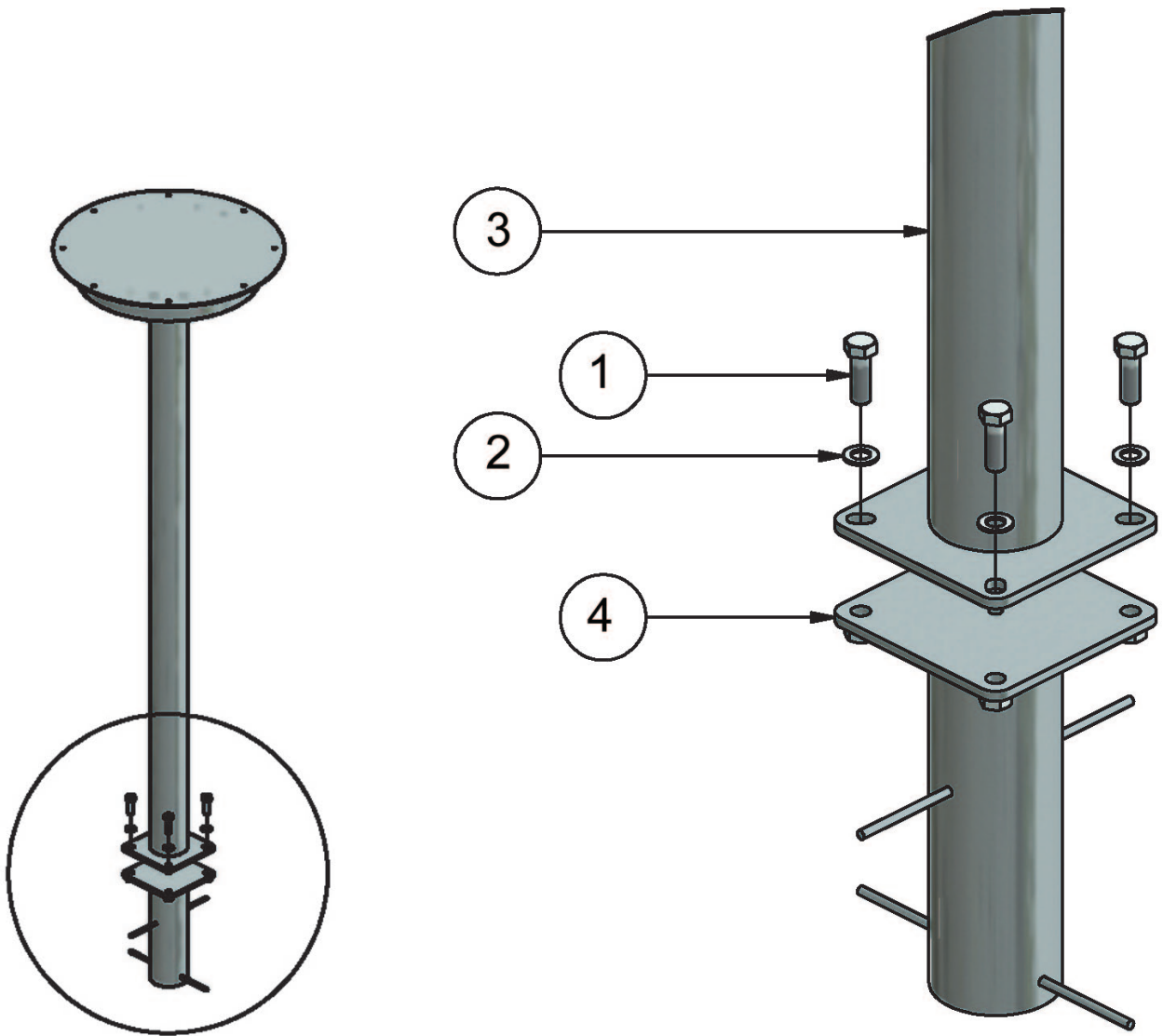

FIXING LIST			
ITEM	STOCK CODE	DESCRIPTION	QTY
1	HSS860	M20 x 60 HEX SET SCREW	4
2	WSR070	M20 PLAIN WASHER	4
3	YOA011P	CENTRAL POST ASSY	1
4	YOA105	GROUND FIXING ASSY GAL	1

YOU070

Pod Shelter Maintenance Instructions

NOTE

The warranty is invalidated if these instructions are not followed.
All wood needs annual inspection and re-treatment where required.

Recommended Regular Inspection and Maintenance

	Interval Days				
	7	14	28	56	365
Check stability of structure, tighten connections if required.	<input type="checkbox"/>	<input type="checkbox"/>	<input type="checkbox"/>	<input checked="" type="checkbox"/>	<input type="checkbox"/>
Check all uprights at ground level for corrosion and/or rot. Replace any defective parts.	<input type="checkbox"/>	<input type="checkbox"/>	<input type="checkbox"/>	<input type="checkbox"/>	<input checked="" type="checkbox"/>
Check all painted elements for damage, rub down and repaint or replace as required.	<input type="checkbox"/>	<input type="checkbox"/>	<input type="checkbox"/>	<input checked="" type="checkbox"/>	<input type="checkbox"/>
Check rubber parts for wear and/or damage, replace if required.	<input type="checkbox"/>	<input type="checkbox"/>	<input checked="" type="checkbox"/>	<input type="checkbox"/>	<input type="checkbox"/>
Check rubber safety surfaces for damage and poor performance, repair or replace if required.	<input type="checkbox"/>	<input type="checkbox"/>	<input type="checkbox"/>	<input checked="" type="checkbox"/>	<input type="checkbox"/>
Check loose fill safety surfaces, remove any foreign elements, rake level and top up if required.	<input type="checkbox"/>	<input type="checkbox"/>	<input checked="" type="checkbox"/>	<input type="checkbox"/>	<input type="checkbox"/>

Disposal Instructions

Waste EEE

Electrical and electronic equipment should never be disposed of with general business waste but must be separately collected for their proper treatment and recovery. The crossed-out bin symbol, placed on the product, reminds you of the need to dispose of the product correctly at the end of its life. In this way you will assist in the recovery, recycling and reuse of many of the materials used in this product. At the end of the life of your product please contact us for information on collection arrangements.

All components should be broken down into categories of:-

- 1 **Mild Steel** - Shelter Side Panels, Shelter Roof Panels, Shelter Seat Rails.
- 2 **Stainless Steel** - Shelter Cranking Handle (Bluetooth Model Only).
- 3 **Galvanised Steel** - Shelter Legs, Shelter Central Post.
- 4 **Moulded Rubber Products without Steel Inserts** - Shelter Roof Panel Edging, Shelter Side Panel Edging.

Wherever possible the following materials should be taken to specialist recycling organisations and recycled. In some cases where composite materials are used, then disposal at land fill sites is the only alternative such as:

- 5 **Waste Batteries** - UK Customers may dispose of their used Batteries free of charge through the BatteryBack Scheme see www.batteryback.org for more information. International Customers should dispose of the Batteries in accordance with local requirements (Bluetooth Model Only).
- 6 **Moulded Rubber Products Encasing Steel Inserts** - Shelter Bluetooth Post Cap (Bluetooth Model Only).
- 7 **High Pressure Laminate** - Bluetooth Instruction Panel (Bluetooth Model Only).