

FACTORY FURNITURE

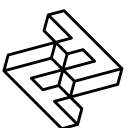

Mantis Seat

OPERATION & MAINTENANCE MANUAL



Introduction

Design

Design, shop drawings and development by Factory Furniture Ltd.

Manufacture

Factory Furniture manufactured components. Products are assembled in Factory workshops, checked and dispatched ready for installation. Replacement products or components thereof should be ordered direct from Factory Furniture Ltd.

Copyright

The design copyright for the product and drawing copyright remains the sole property of Factory Furniture Ltd.

General Specifications

Seat

Metric length 2145mm | width 705mm | height 730mm
Imperial length 7' ½" | width 2' 4" | height 2' 4½"

Approx Weight 74kg

Fixing Centres 2105mm (6' 11") x 575mm (1' 10½")*

*Also central fixing point

Detailed Material & Finish Specifications

Seat Slats / Back Slats

- Slats are manufactured from FSC® certified tropical hardwood or FSC certified oak (*other FSC timber options available upon request*).
- Slats are profiled and left untreated as standard (*oil or microporous woodstain treatment available on request*)
- Slats mounted on aluminium frame (*2 side legs and 1 central leg*) with 5 no. fixing points in total per slat (*except for rear 2 seat top slats which have 3 no. fixing points per seat*)



Frame (Side legs and central leg)

- Manufactured from cast aluminium with a polyester powder-coated finish (*powder-coat colour: grey as standard or to customer specification*)
- Side legs anchored using 2 no. resin fixed M10 x 200mm threaded rods and cap nuts per base
- Central leg anchored 1 no. resin fixed M10 x 200mm

General Maintenance

(Recommended Schedule & Guidelines)

Daily/Weekly/Monthly (or as adopted)

Visual checks of seat top, back and bases - check all items for superficial or physical damage.

Three Monthly

Clean all items as detailed below check all fixings are seated correctly; inspect timber for serious damage and splinters.

Six Monthly

Secure all fixings; full clean as detailed below; check that seat/bench is firmly secured to the ground.

Specific Maintenance Details

FSC Timber

Clean with a stiff brush once per year, especially in more exposed locations, in order to prevent a verdigris type build up on the timber surface. Ideally this should be completed in early spring. During the cleaning stage, all exposed timber surfaces should be inspected for splits and splinters. Any splinters and graffiti should be removed and the surface sanded with 100 grit sandpaper in order to remove any uneven / sharp edges or surfaces.

During the first few months after installation the tannin naturally occurring in the timber may leach out and cause a brown staining on the bases. This may be removed with a light solution of household bleach and water.

Polyester Powder Coated Aluminium

For general cleaning using a damp cloth and warm soapy water only. Scourers and abrasive cleaners are NOT suitable for this type of finish and may damage it. Before using any cleaning agents to remove graffiti etc. try on a small, inconspicuous area first to avoid causing more unsightly damage.

Repairs

FSC Timber

For light damage, please see section on specific maintenance details above. For instances of heavy damage, the timber item should be replaced. Please order against the part number reference in the reordering section towards the end of this manual.

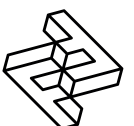

Polyester Powder Coated Surfaces

For light damage (scratches, chips etc.) repair using touch-up paint to match original colour (available from Factory Furniture Ltd). Paint application should be carried out in accordance with approved methods detailed by the paint manufacturer. Please note that it is advisable to use professional painters to achieve best results when touching up larger areas. Products for respraying larger areas are available from Factory Furniture Ltd.

Heavy Damage

In the event of serious damage to any component, replacements should be ordered from Factory Furniture Ltd. Should further assistance be required (or if the product needs to be disassembled for any reason), please contact Factory Furniture for detailed technical advice.

Reordering / Spares

(Part No. & Item Description)

P1005/ 01

1 no. Mantis slat set (6 slats in total)

P1005 / 02

1 no. Mantis right Leg

P1005/ 03

1 no. Mantis left Leg

P1005 / 04

1 no. Mantis central Leg

Instructions For Reordering

If possible, please specify job name or number at the time of reordering to enable identification of details such as the original species of timber used, stainless steel finishes and polyester powder coat colours etc. In any event where either, additional orders are required, or spares and replacements are required please contact Factory Furniture Ltd. Using the part numbers given above as reference should help us to process your enquiry more efficiently.

Note - All fittings required to assemble ordered parts will automatically be included in the order.

AutoCAD Drawing List

FF1005 / 01

MANTIS SEAT
SEAT FABRICATION DRAWINGS

FF1005 / 02

MANTIS SEAT
PART DETAILS DRAWING (SIDE FRAME)

FF1005 / 03

MANTIS SEAT
PART DETAILS DRAWING (CENTRE FRAME & SLATS)

FF1005/ 04

MANTIS SEAT
SETTING OUT DRAWING

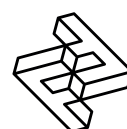

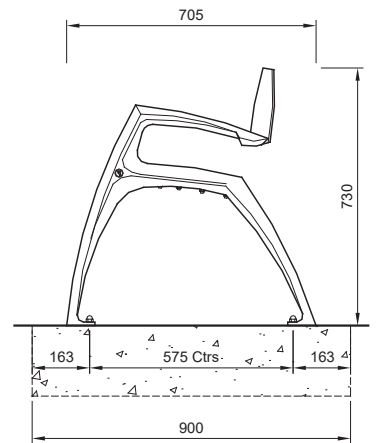
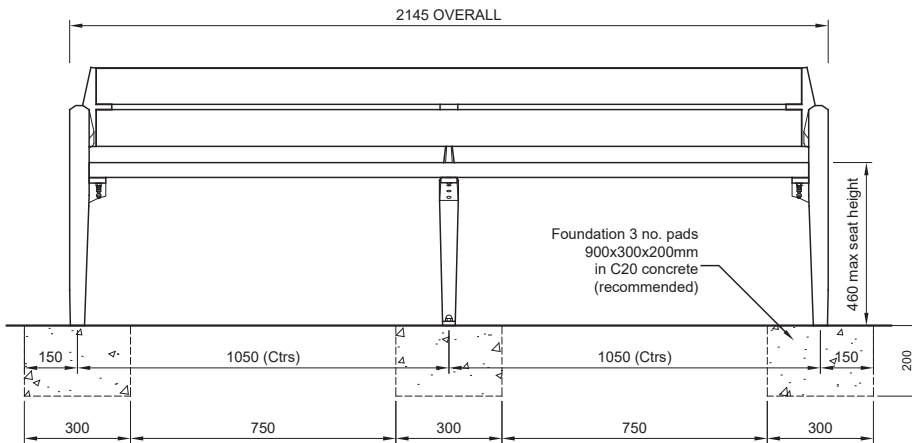

Installation Instructions

All installation works to be carried out by competent personnel - install as complete unit.

Mantis seat

1. Install suitable foundation with top face at ground level.
2. Position seat in correct orientation with bases centrally on foundation pads; then mark hole positions through fixing lugs on legs (5 no. holes in total).
3. Remove the bench; drill holes $\text{\O}14\text{mm} \times 200\text{mm}$ deep.
4. Clear debris from holes.
5. Fill the holes to within approximately 35mm from the top with Hilti HY150 resin (or similar). Lift the seat (with threaded anchor rods/capnuts in place) and carefully lower the anchors into the holes, leave for two hours before using.
6. Using a torque wrench, tighten nuts and washers onto fixing lugs to 30Nm to securely fasten the seat. (Check that seat remains level during fixing process)

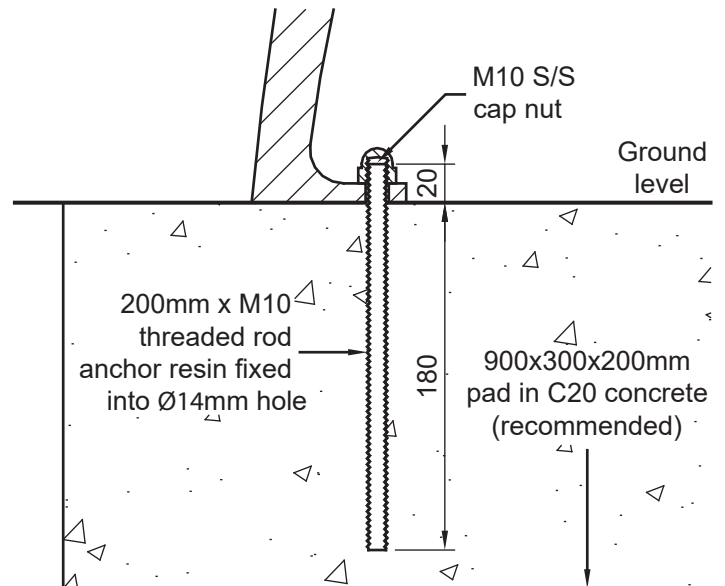

5 Pioneer Road, Faringdon,
Oxfordshire SN7 7BU
+44 (0)1367 242731
hello@factoryfurniture.co.uk

