

# FACTORY FURNITURE

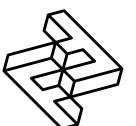

## Mantis Seat

TECHNICAL SHEET



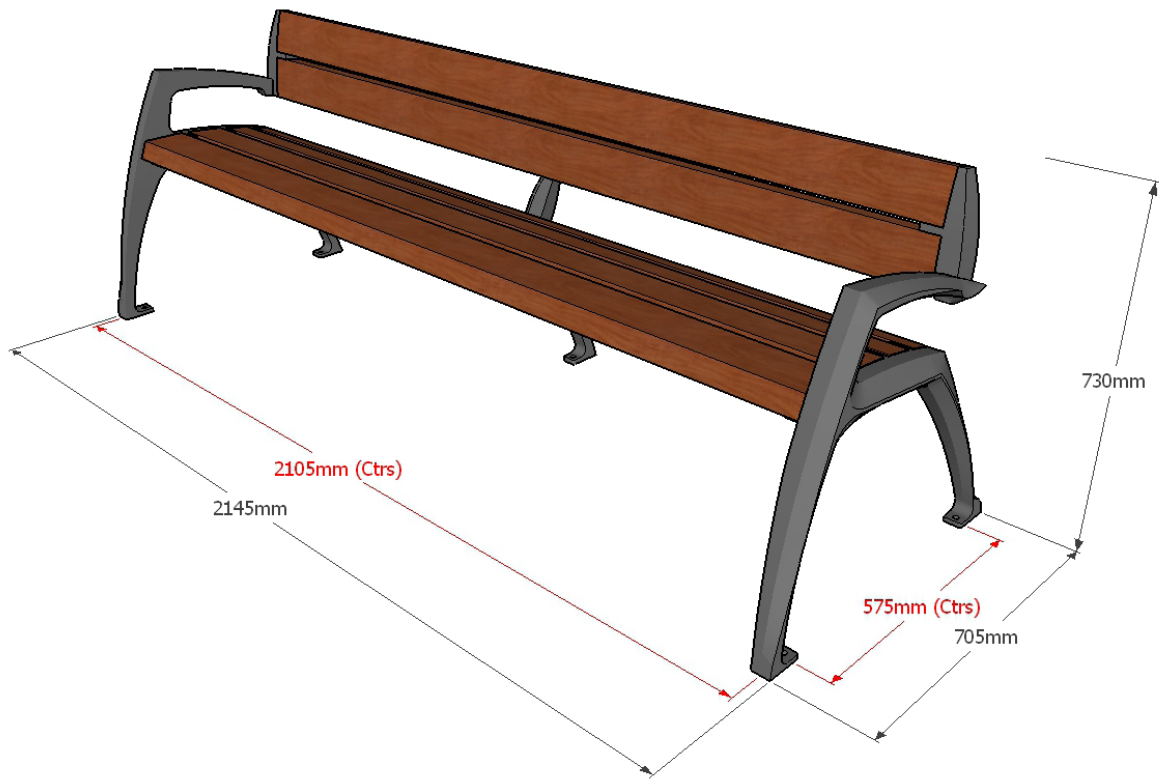

## Composition

Seat/back - FSC® certified tropical hardwood or FSC® certified oak  
 Frame - Cast aluminium



## Finish

Natural finish as standard. (Oil or microporous wood-stain available on request). Aluminium is polyester powder-coated (grey as standard or as per client specification)

## Dimensions

Metric L - 2145mm | W - 705mm | H - 730mm  
 Imperial L - 7' ½" | W - 2' 4" | H - 2' 4½"

## Approx weight

74kg

## Fixing centres

2105mm (6' 11") x 575mm (1' 10½")

## Fixing method

5 resin fixed anchors into base lugs (2 per side & 1 central)

## Foundation

2 no. pads 900 x 300 x 200 mm in C20 concrete (recommendation only)

## Handling

Please observe health & safety lifting guidelines. A fork lift or crane will be required for off loading and positioning of items

## Maintenance

Depends on usage and position. All elements will require annual cleaning. Wood should be treated every other year if coated. Polyester powder-coated aluminium will require maintenance only if damaged. Further maintenance. Polyester powder-coated aluminium will require maintenance only if damaged.

