

**Play value**

The observer gently spins the disc and then takes a step back. Looking at the disc the eye actively and automatically creates complementary and polar counter images. The sense of sight thus fulfils a basic principle of nature: maintaining the unity in a variety of perceptions, and thus through this unity maintaining the diversity. As a result of the turning motion of the Rotating Discs, observers see a dynamic penetration of the light and dark rotating parts. This creates surprising, colourful light phenomena.

**Recommended for**

- Kindergarten children
- School children
- Young people
- Adults
- Older people
- Public play areas without supervision, such as playgrounds, parks or similar



Order No. 10.22505 Spiral 2 with post made of stainless steel, Photo © Liz Ligon



Photo © Daniel Perales

**Rotating Discs**

Vandalism	slightly vulnerable
Supervision	not necessary
Explanation Board	recommended
Installation	indoors and outdoors
Safety check (DIN EN 1176)	not necessary
Installation in concrete	possible





Order No. 10.22450 Rotating Coloured Disc for wall attachment

### Colour Disc

The disc is divided into blue and yellow sectors. Turning creates not only a mixture of colours, but also the colour green and after that the complementary colour red. The observer experiences the effect of colour as a physical, non-material appearance.



Order No. 10.22850 Spiral 2 for wall attachment



Order No. 10.22550 Funnel 2 for wall attachment



Order No. 10.22350 Pulsation for wall attachment



**Spiral**

When the observer turns the disc clockwise, the spiral appears to expand further and further. Turning the disc the opposite way forms a continually deepening funnel. The eye attempts to compensate the one-sidedness of the rotation by involuntarily jumping from one spiral line to the next. This counteraction has the effect of appearing to slow down the rotation and make the funnel grow larger. The complementary colours appear on the borders of the black pattern. If the gaze is diverted from the disc then it appears as if the entire surroundings expand or contract in contrast to the image last seen on the disc - as if in slow motion - resulting in great astonishment. The eye „compensates“. By seeing the complementary colours, a fundamental principle of light becomes visible: colour as the dynamic penetration of dark and light in the form of black and white spiral lines.

**Funnel**

Turning the disc slowly creates the impression of a rotating cone and funnel, around which there are regular black and white stripes. The impression remains unchanged even if the observer looks at it from different angles. The reason is that the eye seeks a virtual centre in the asymmetrical pattern. However, it can only achieve this by creating a third dimension, namely perspective, thus making the cone or funnel appear three-dimensional.

**Pulsation**

Here the eye perceives a pulsating physical motion similar to breathing in and out. The square and circle play around each other, pulling together and drawing outwards.



Order No. 10.22550 Spiral 2 as wall attachment



Order No. 10.22450 Colour Disc as wall attachment



Special Versions



Order No. 10.22505 Spiral 2 with post made of stainless steel, Photo © Paul Upward

**Rotating Discs**

© Richter Spielgeräte GmbH 11/22

Design W. Graubner based on H. Kükelhaus



10.22100 - 10.22850

**Order No. 10.22100 - 10.22850**  
**Rotating Discs**

Safety distance →  
 Device dimensions —●—  
 Functional distance —|—

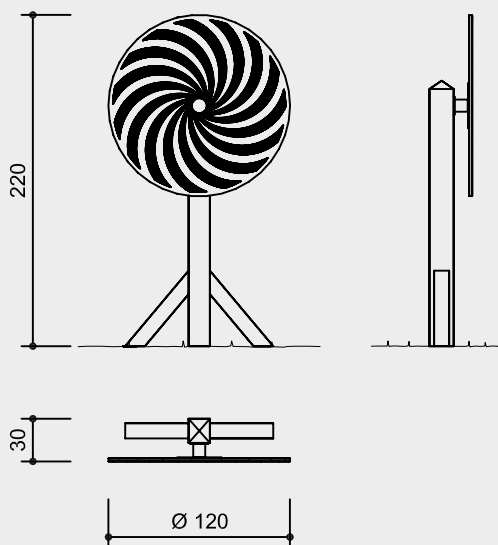

Scale 1:50

**Technical information**

Frame made of oak

**Core-free**

Sawn-timbers core-free, thus decreasing occurrences of cracking and undesired changes in shape



**Ground anchor**

All parts used for anchoring to the ground are made of hot-dip galvanised steel or stainless steel



**Roller bearings**

High-quality roller bearings made of chrome steel or stainless steel for rotating elements, easy to maintain and exchange, sealed



**For more detailed explanation of the quality characteristics see price list.**

Maintenance-free ball bearing (for enduring motion)

Flange and fastening screws made of stainless steel

Supports made of special plastic

Large-format patterned disc with sufficient motion mass

Precise black and white or coloured print with weather-resistant, special protective paint

Anti-glare surface

**Dimensions**

(small deviations possible)

Height	2.20 m
Depth	0.30 m
Disc diameter	1.20 m
Weight	80 kg

**Components**

- 1 Stand Frame with steel foot
- 1 Disc with pattern and bearing, fastening material included

**Trademark**

30 2005 500 000 Germany  
 40-0682207 South Korea

Explanation board on request

**Installation information**

Recommended space  
 6.00 x 2.50 m

**Foundations**

**Stand Frame made of wood**

- 1 item 40 x 40 x 40 cm  
 Excavation depth 60 cm
- 2 items 30 x 50 x 30 cm  
 Excavation depth 50 cm

**Stand post made of stainless steel**

- 1 item 60 x 60 x 60 cm  
 Excavation depth 80 cm

Order No.	Item	Motive
10.22100	Spiral with stand frame made of wood	
10.22105	Spiral with stand post made of stainless steel	
10.22150	Spiral for wall attachment	
10.22200	Funnel with stand frame made of wood	
10.22205	Funnel with stand post made of stainless steel	
10.22250	Funnel for wall attachment	
10.22300	Pulsation with stand frame made of wood	
10.22305	Pulsation with stand post made of stainless steel	
10.22350	Pulsation for wall attachment	
10.22400	Colour disc with stand frame made of wood	
10.22405	Colour disc with stand post made of stainless steel	
10.22450	Colour disc for wall attachment	
10.22500	Funnel 2 with stand frame made of wood	
10.22505	Funnel 2 with stand post made of stainless steel	
10.22550	Funnel 2 for wall attachment	
10.22600	Pulsation 2 with stand frame made of wood	
10.22605	Pulsation 2 with stand post made of stainless steel	
10.22650	Pulsation 2 for wall attachment	
10.22700	Pulsation 3 with stand frame made of wood	
10.22705	Pulsation 3 with stand post made of stainless steel	
10.22750	Pulsation 3 for wall attachment	
10.22800	Spiral 2 with stand frame made of wood	
10.22805	Spiral 2 with stand post made of stainless steel	
10.22850	Spiral 2 for wall attachment	

**Attention:**  
 Exact measurements may vary;  
 for all installation dimensions refer  
 to current assembly instructions.  
 Technical changes reserved.

**Equipment also available with  
 stainless steel stand post or for wall  
 attachment (see table).**



10.22100 - 10.22850