

# Installation Instructions

## Ground Fixed

Papilio Bells  
Page 1 of 5



### Instrument Components:

x4

M8 Barrel Nuts

x4

M6 Saddle Straps

x8

M6x20mm Secure Screw

x4

M8 Square Nut

x4

M6x12mm Secure Screw

x4

M8 Nyloc Nut

Metric Conversion:  
250mm/ 10"  
550mm/ 22"  
1240mm/ 49"  
1.5m/ 59"

(1.1)

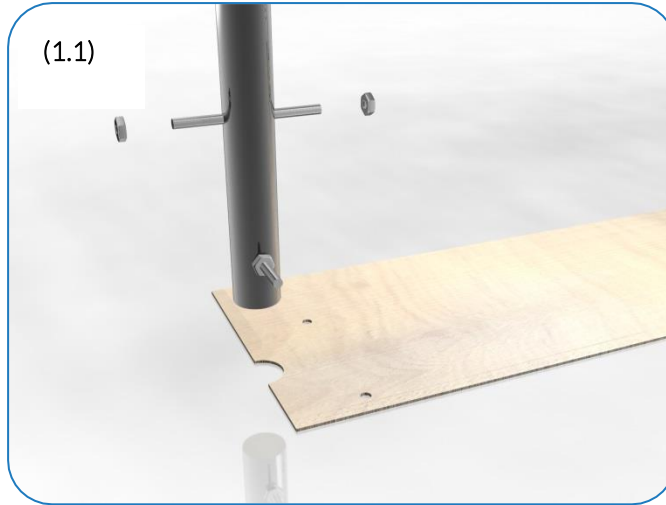

1. Attach M10x150 Bar and Nuts to each of the 3 Legs.  
**(1.1) (See Assembly Guide)**

2. Use wooden jig to mark out hole positions for each of the 3 legs in desired location upon decision from customer.

3. Excavate 3 holes for the Steel legs 250mm diameter by 550mm deep. (See GF Post Installation Sheet)

4. Locate (lower) legs into holes making sure they are vertical and level and use jig to check positioning.

5. Once happy with location of the Instrument, **fill** hole using rapid hardening **concrete**. Be sure to compact concrete around legs and leave to dry according to manufactures guidelines, making sure to leave jig in place until set.

6. Once concrete has set, remove wooden jig and install notes using Fixings provided. Finally install beaters using fixings provided.  
**(See Assembly Guide)**

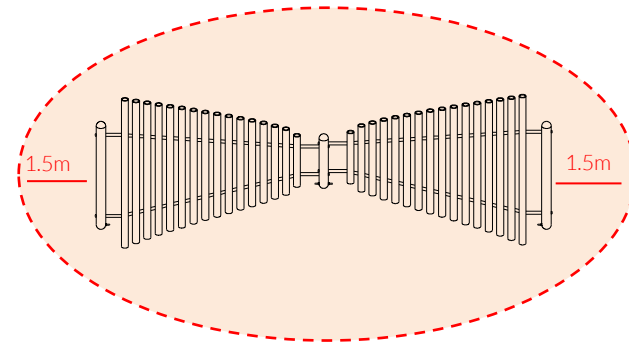

Install Instrument with 1.5m free space (from widest point) around it.

**CAUTION:** Papilio surface can get hot in direct sunlight, if possible install in shaded areas.

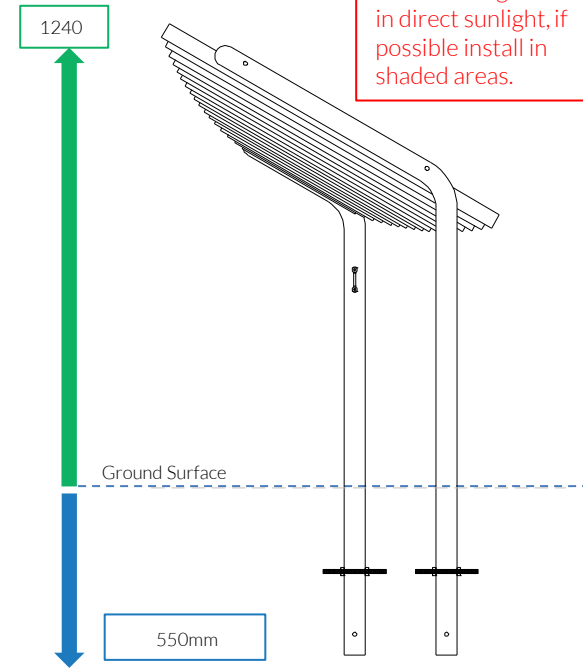
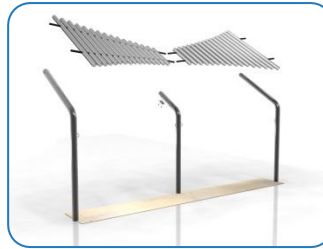

Weight of heaviest part **13kg** (Notes)



Single Small Red Beaters X4

Ground Fix Components:



x6  
M10x200 Threaded Bar



x12  
M10 Nut



Spares available from [percussionplay.com](http://percussionplay.com) or from your local distributor

36 Kg

Tools:

TX 30 Driver Bit x1 TX 40 Driver Bit x1

Ground Fixed  
Papilio Bells  
Page 2 of 5

Instrument Components:

- x4  
M8 Barrel Nuts
- x4  
M6 Saddle Straps
- x8
- x4
- x4
- x4

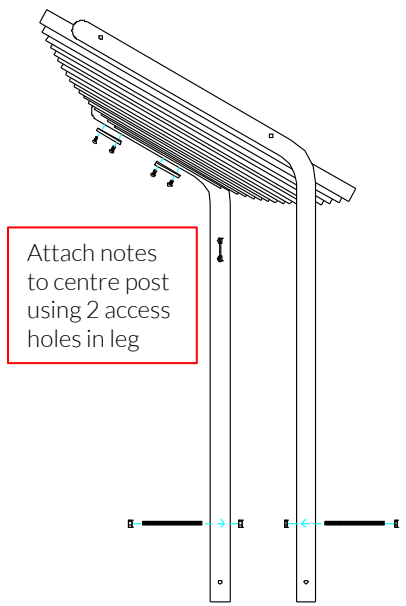

**CAUTION:** Papilio Bells surface can get hot in direct sunlight, if possible install in shaded areas.

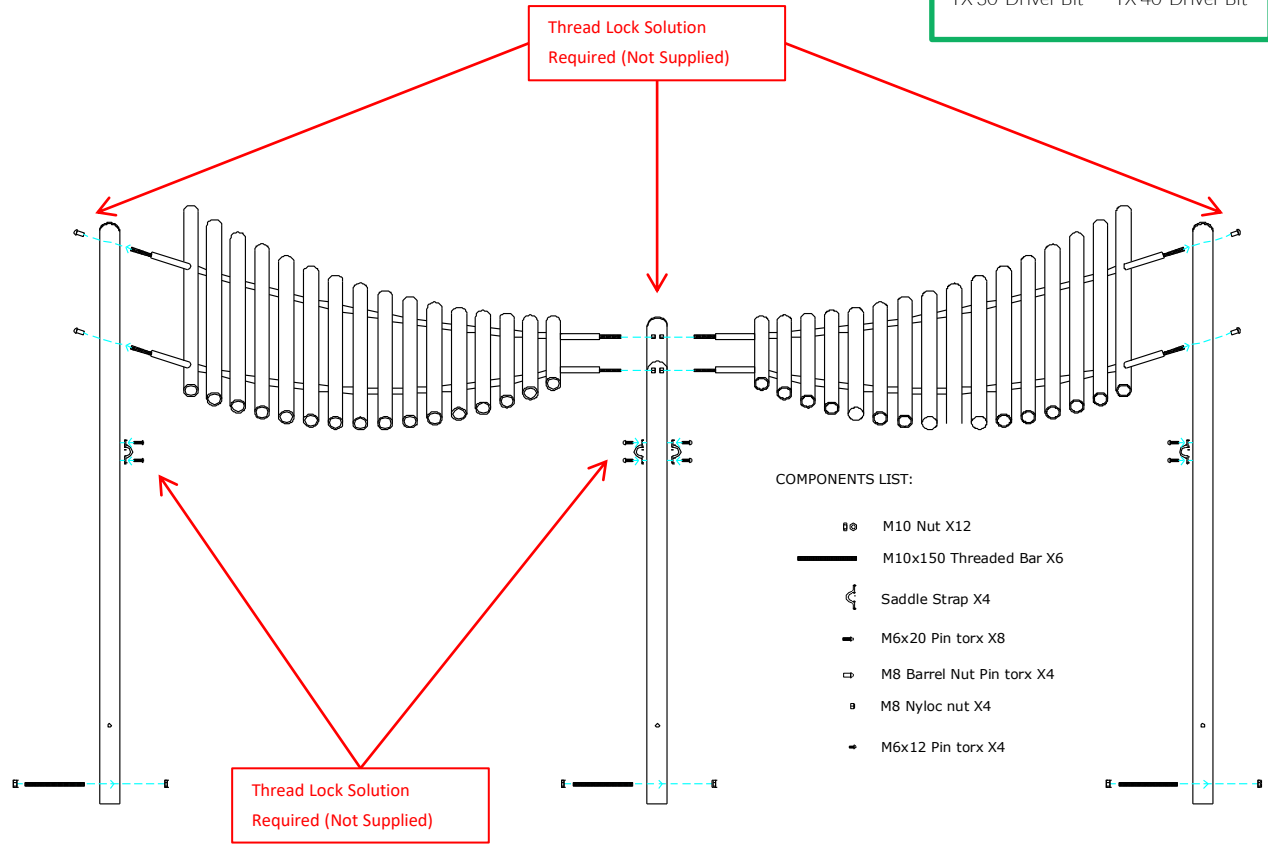

- COMPONENTS LIST:
- M10 Nut X12
  - M10x150 Threaded Bar X6
  - Saddle Strap X4
  - M6x20 Pin torx X8
  - M8 Barrel Nut Pin torx X4
  - M8 Nyloc nut X4
  - M6x12 Pin torx X4

Thread Lock Solution Required (Not Supplied)

Single Small Red Beaters X4

Ground Fix Components:

- x6  
M10x200 Threaded Bar
- x12  
M10 Nut

Spares available from [percussionplay.com](http://percussionplay.com) or from your local distributor

15 Kg

# Ground Fix Post Installation

## Ground Fixed

Papilio Bells  
Page 3 of 5



### Components:

-  x6  
M10x200  
Threaded Bar
-  x12  
M10 Nut

Metric Conversion:  
50mm/2"  
220mm/8 21/32"  
250mm/10"  
350mm/14"  
550mm/22"  
600mm/24"  
1200mm/3ft 11 1/4"  
2400mm/7ft 10 31/64"

1

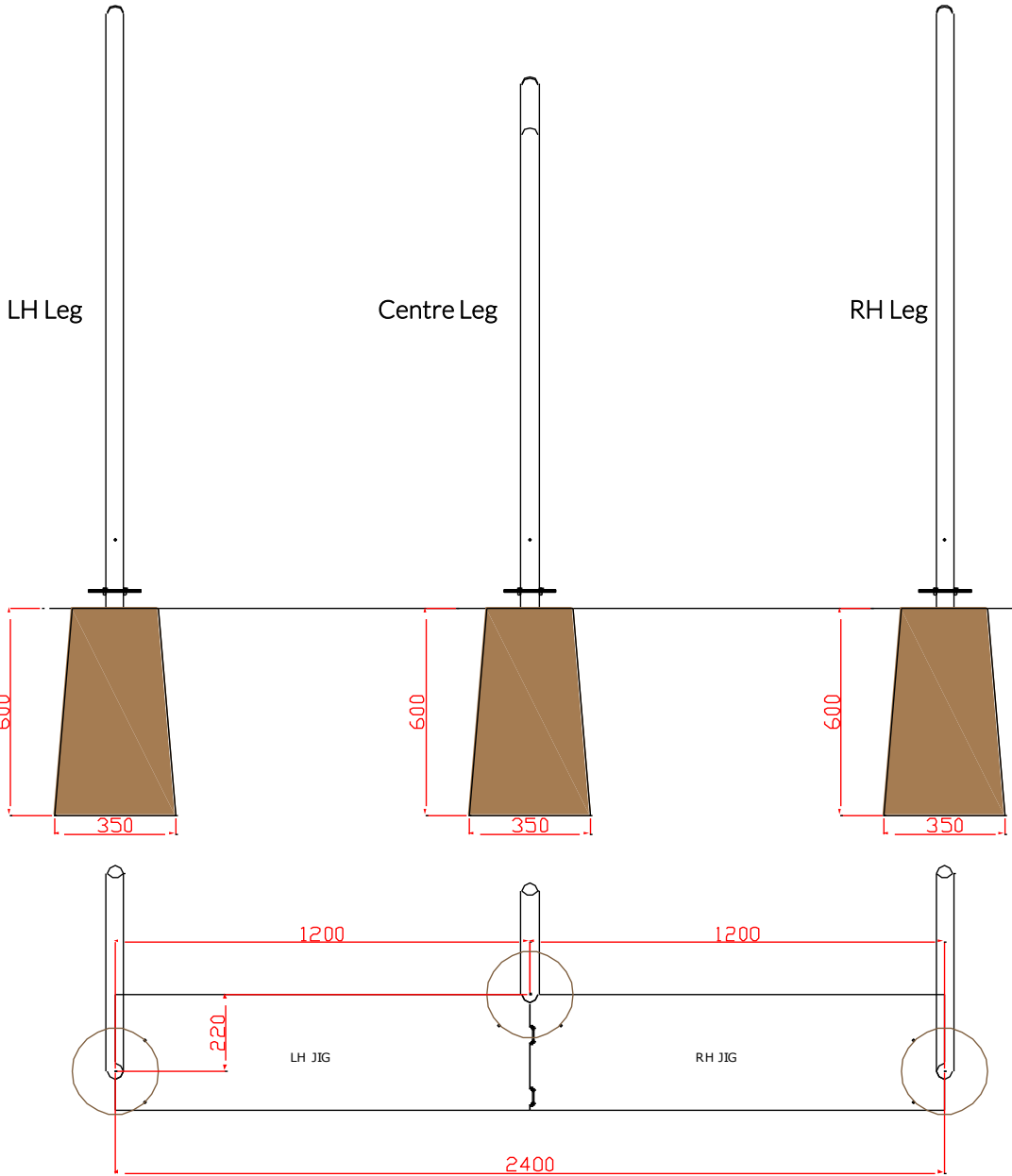

550mm min depth

Using Wooden Jig provided Excavate 3 holes with a 250mm diameter tapering down to 350mm diameter and 600mm depth



# Ground Fix Post Installation

Foundations should not present a hazard. These foundations are recommended as a guide, for more information on foundation details for various surface see Part 1 of BS EN 1176.

## Ground Fixed

Papilio Bells  
Page 4 of 5



### Components:

-  x6  
M10x200  
Threaded Bar
-  x12  
M10 Nut

### Metric Conversion:

- 50mm/2"
- 220mm/8 21/32"
- 250mm/10"
- 350mm/14"
- 550mm/22"
- 600mm/24"
- 989mm/3ft 2 15/16"
- 1171mm/3ft 10 7/64"
- 1195mm/3ft 11 3/64"

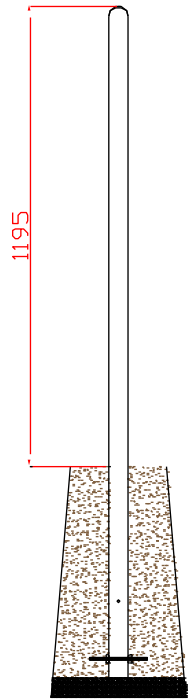
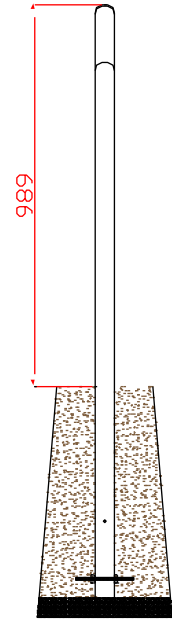
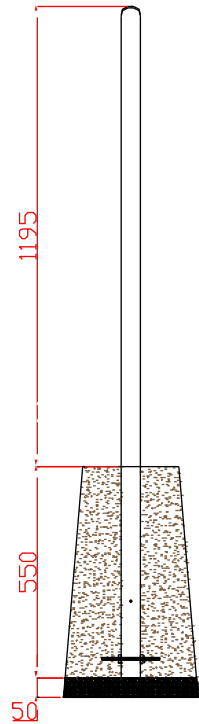
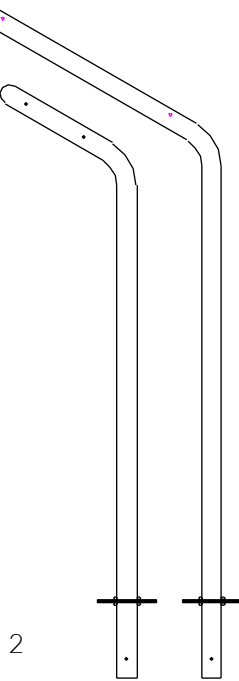

### Internal diagonal distances between note fixing holes

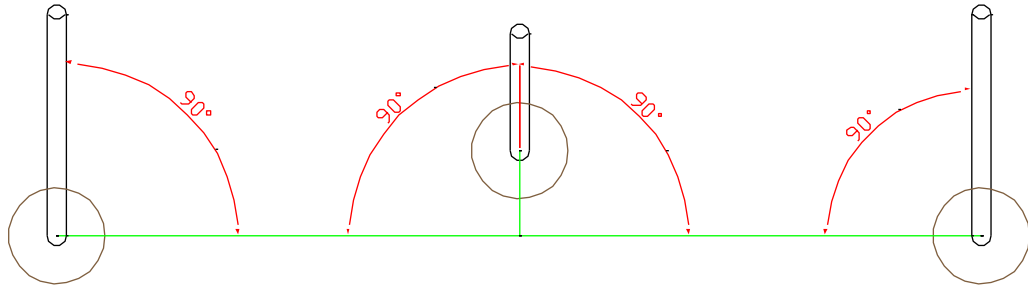
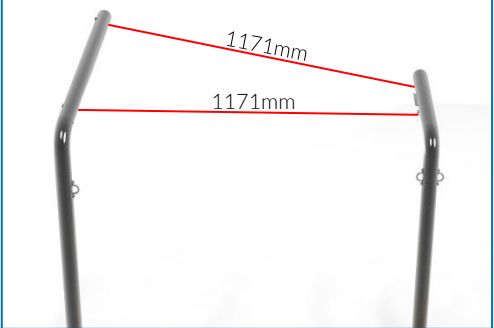

Compact base of hole with 50mm of aggregate. Lower ground Fix posts attached to instrument straight and level, and at correct height before filling with concrete)



MADE IN BRITAIN

BS EN 1176

# Ground Fix Post Installation

Foundations should not present a hazard. These foundations are recommended as a guide, for more information on foundation details for various surface see Part 1 of BS EN 1176.

## Ground Fixed

Papilio Bells  
Page 5 of 5



Centre Post has 2 cover panels to hide access hole where the notes are attached.

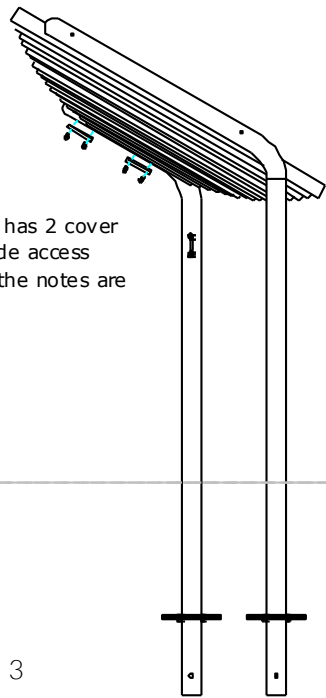

3

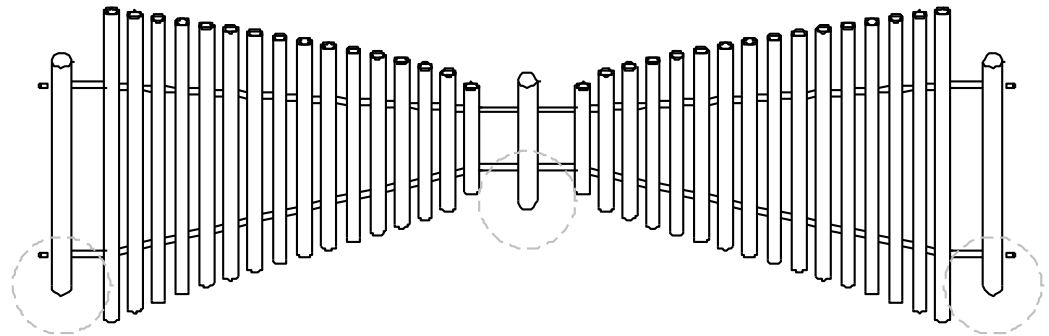
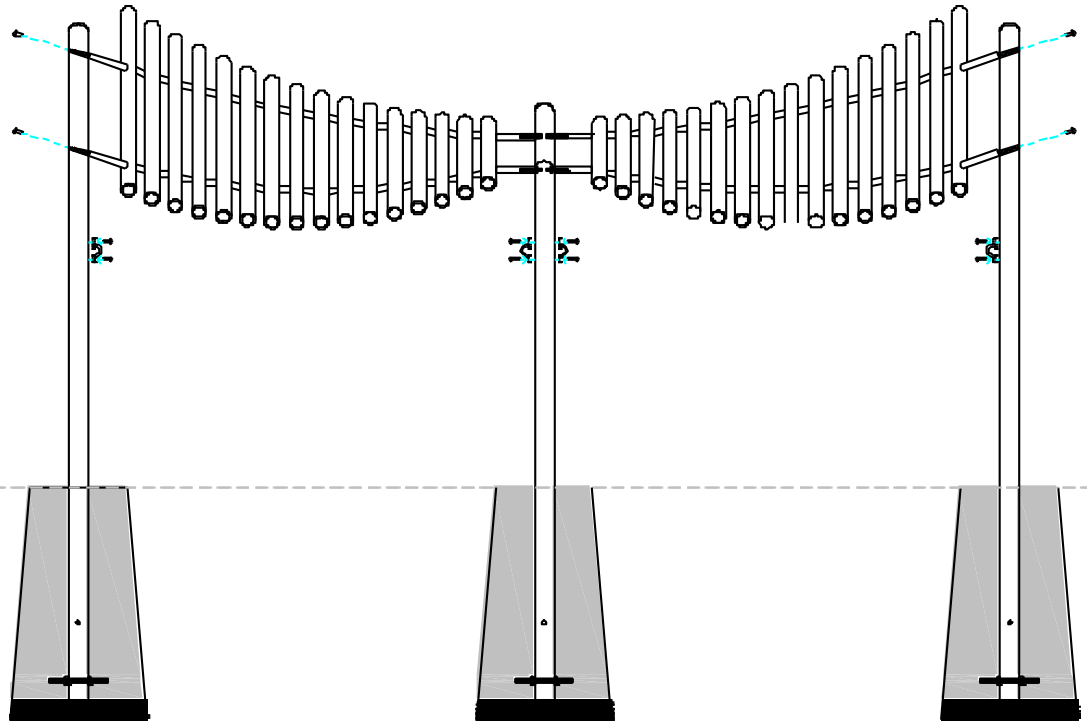

Fill hole with fast drying concrete to manufacturers specifications. If posts protrude above instrument they can be cut down, Once concrete has set install the notes and beaters with fixings provided



## Components:

 x6  
M10x200  
Threaded Bar

 x12  
M10 Nut

Metric Conversion:  
50mm/2"  
220mm/8 21/32"  
250mm/10"  
350mm/14"  
550mm/22"  
600mm/24"  
1200mm/3ft 11 1/4"  
2400mm/7ft 10 31/64"