

Installation Instructions

Ground Fixed

TUTTI
Page 1 of 3



Instrument Components:

-  x18
-  x9
-  x6

Metric Conversion:
300mm/ 12"
350mm/ 14"
1555mm/ 61"
1.5m/ 59"

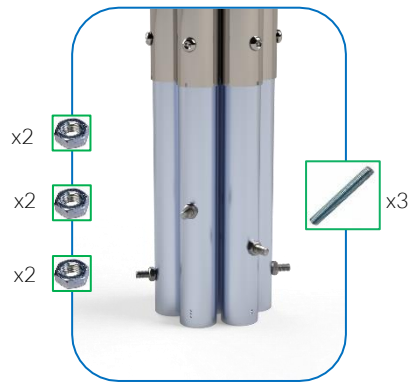

Weight of heaviest part (TUTTI Frame)

1. Lay packaging out on floor or assemble on non-abrasive surface to prevent marking of polished stainless steel.

2. Align and secure each angled post to the centre post using M8x60mm security screws. Use the ident markers at their bases for reference. **(See Assembly Guide Sheet).**

3. Sheath the posts of over their Ground Fix Stanchions in ascending order, using the ident markers at the bases of the stanchions for reference. **(See Assembly Guide Sheet).** Secure with M10x30mm Security Screws.

4. Insert the Central Ground Fix Stanchion (no ident) between the now fixed six. Align with outer stanchion holes and insert M10x200mm Studs, securing evenly with M10 Nuts.

5. Attach 3No. Notes Panels to Frame and beaters to each arm, at the base of each note panel fixing.

6. Excavate 1 hole for the Steel leg 300mm diameter by **minimum 350mm deep**, in desired location upon decision from customer.

7. Fill bottom 50mm with compacted aggregate.

8. Locate (lower) leg into hole making sure it is vertical and level prior to concreting in place.

9. Once happy with location of the instrument, **fill** hole using rapid hardening **concrete**. Be sure to compact concrete around leg and leave to dry according to manufactures guidelines.

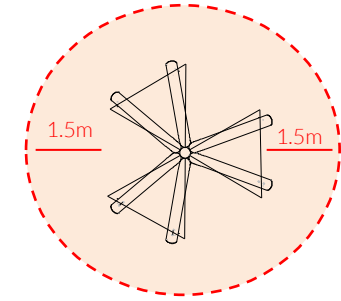

Install Instrument with 1.5m free space (from widest point) around it.

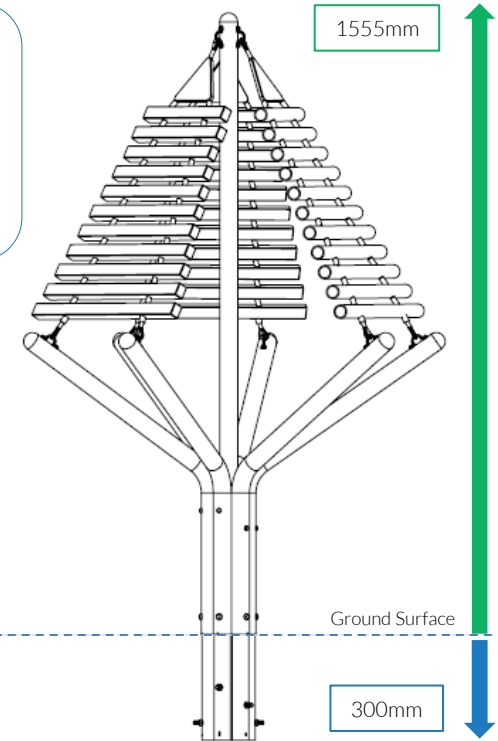

CAUTION: TUTTI surface can get hot in direct sunlight, if possible install in shaded areas.



Pair Small Red Beaters X3

Ground Fix Components:



x6

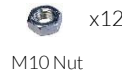

x12





x6



Spares available from percussionplay.com or from your local distributor

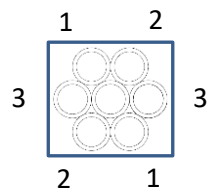
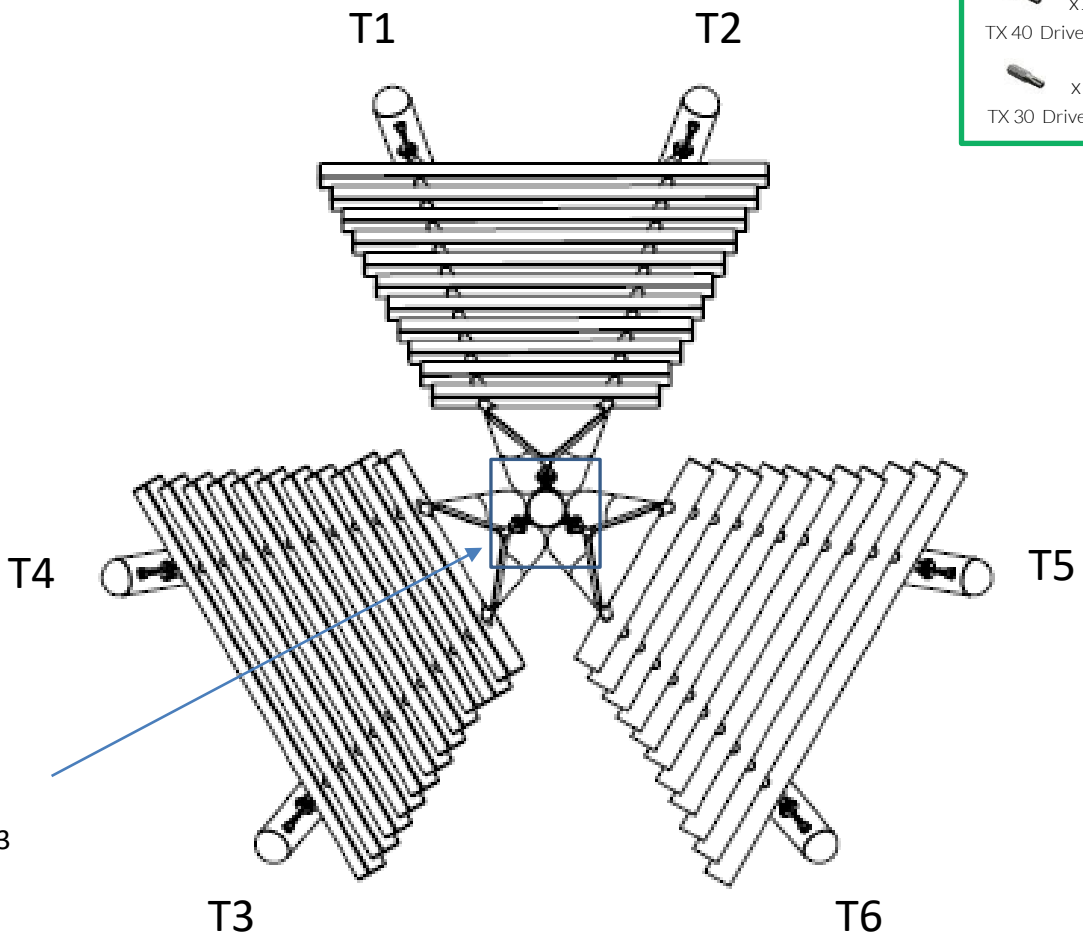

55 Kg

- Tools:**
-  x1
TX 45 Driver Bit
 -  x1
TX 40 Driver Bit
 -  x1
TX 30 Driver Bit





Ground Fixed
TUTTI
Page 2 of 3



- Components:**
-  x6
M10x200 Threaded Bar
 -  x12
M10 Nut
 -  x6
M8x60 Security Screw

Thread Lock Solution
Required (Not Supplied)



- Ground Fix Components:**
-  x6
M10x200 Threaded Bar
 -  x12
M10 Nut
 -  x6
M10x30 Security Screw



Spares available from
percussionplay.com or from your
local distributor

55 Kg

Foundations should not present a hazard. These foundations are recommended as a guide, for more information on foundation details for various surface see Part 1 of BS EN 1176.

Ground Fixed

TUTTI
Page 3 of 3

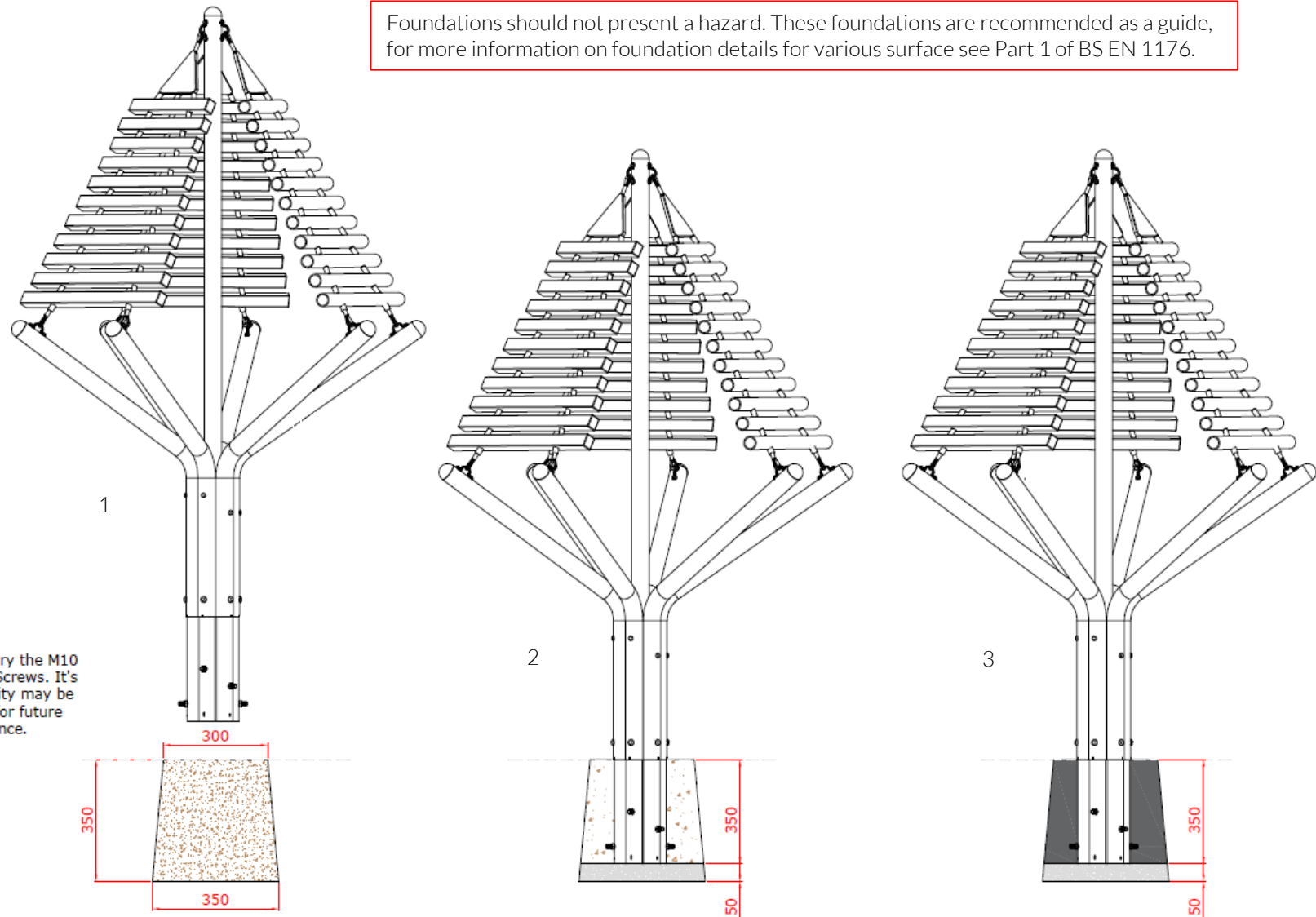

Do not bury the M10 Security Screws. It's accessibility may be required for future maintenance.



Excavate a hole with a 300mm diameter tapering down to 350mm diameter and 350mm depth

Compact base of hole with 50mm of aggregate. Lower Ground Fix Post attached to instrument into hole (check instrument straight and level before filling with concrete)

Fill hole with fast drying concrete to manufacturers specifications.



Components:

-  x6
M10x200 Threaded Bar
-  x12
M10 Nut
-  x6
M10x30 Security Screw

Metric Conversion:
50mm/ 2"
300mm/ 12"
350mm/ 14"

