

Installation Instructions

Ground Fixed

Duo
Page 1 of 4

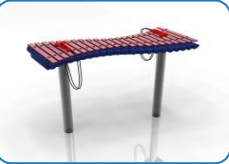

Instrument Components:

-  x8
M8 Nyloc Nut
-  x4
M6x20 Security Screw
-  x8
2 Part Cover Cap
-  x2
M6 Saddle Strap

Metric Conversion:
250mm/ 10"
400mm/ 15 3/4"
550mm/ 21 21/32"
700mm/ 27 9/16"
850mm/ 33 15/32"
1.5m/ 59"

Weight of heaviest part 14kg (Duo)

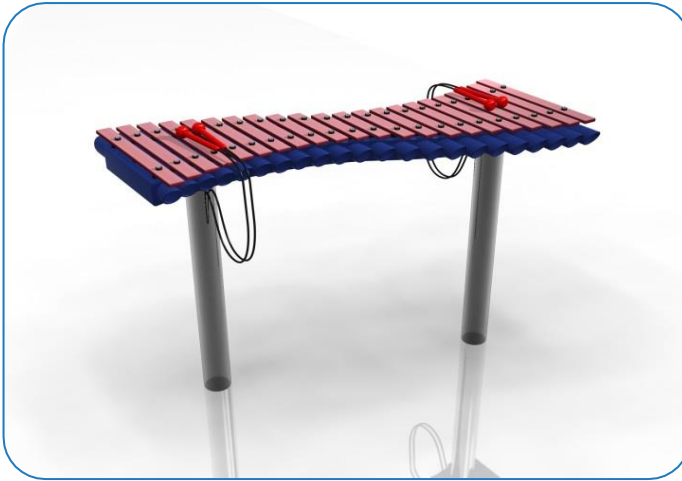

1. Attach the steel legs to the base of the instrument with the M8 Nyloc Nuts and 2 part security caps. (1.1) (See Assembly Guide).

2. Attach Ground Fixing posts to legs (1.2) (See Ground Fix Post Installation Sheet).

3. Excavate 2 holes for the Steel legs 250mm diameter by 400-550mm deep depending on Key stage, in desired location upon decision from customer.

4. Locate (lower) legs into holes making sure they are vertical and level prior to concreting in place.

5. Once happy with location of the Instrument, fill holes using rapid hardening concrete. Be sure to compact concrete around legs and leave to dry according to manufactures guidelines.

6. Attach the 1 pair of beater to the saddle strap on the leg. (1.3)

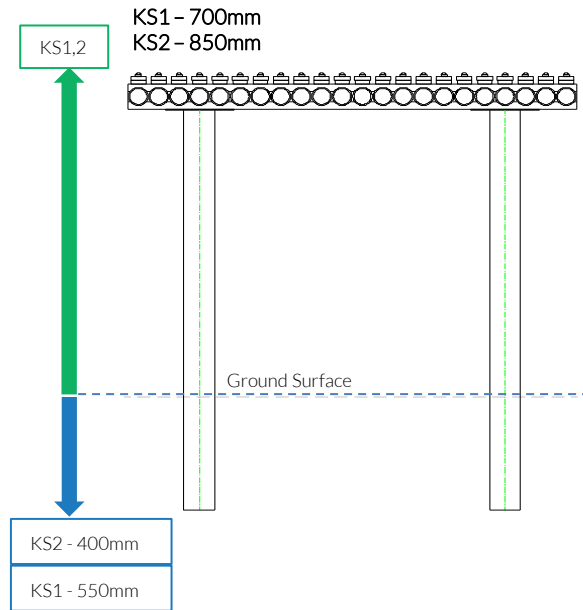
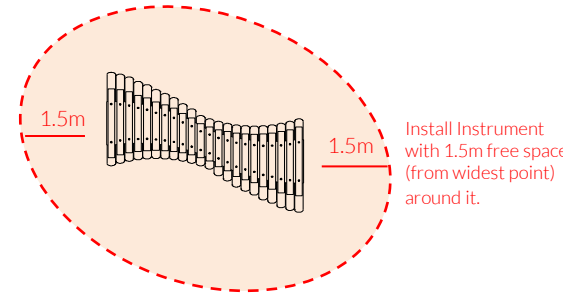

Ground Fix Components:





Spares available from percussionplay.com or from your local distributor

28 Kg

Assembly Guide PDDUO

Tools:

 x1
  x1

Ground Fixed Duo
Page 2 of 4







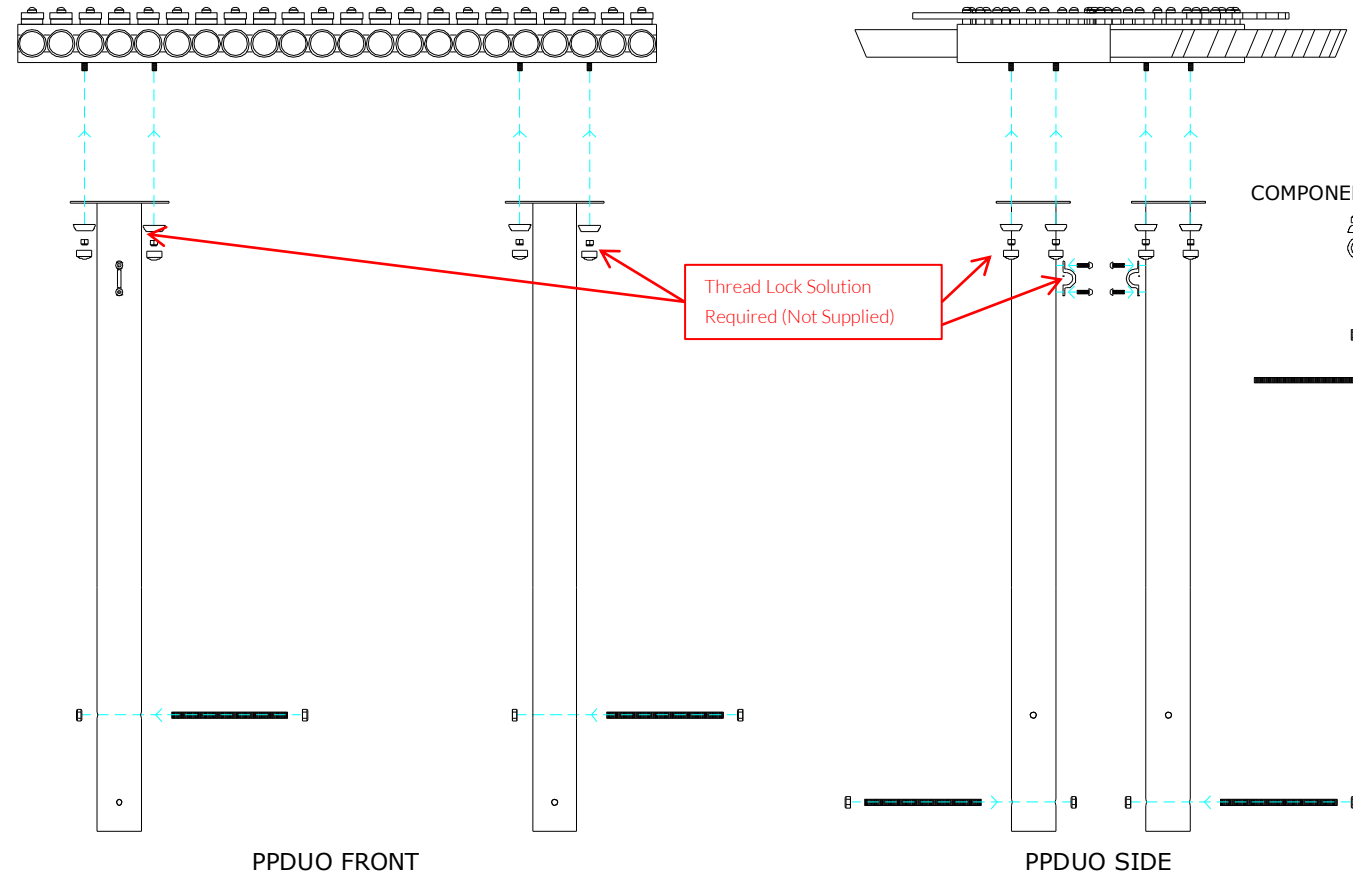

Components:

-  x8
M8 Nyloc Nut
-  x4
M6x20 Security Screw
-  x8
2 Part Cover Cap
-  x2
M6 Saddle Strap

Thread Lock Solution Required (Not Supplied)



- COMPONENTS LIST:**
-  2 Part Cover Cap X8
 -  M8 Nyloc nut X8
 -  M10 Nut X8
 -  M10x200 Threaded Bar X4
 -  Saddle Strap X2
 -  M6x20 Pin torx X4



Pair Small Red Beaters X2

Ground Fix Components:

 x4
M10x200 Threaded Bar
  x8
M10 Nut

Spares available from percussionplay.com or from your local distributor

28 Kg

Ground Fix Post Installation

Foundations should not present a hazard. These foundations are recommended as a guide, for more information on foundation details for various surface see Part 7 of BS EN 1176.

Ground Fixed

Duo
Page 3 of 4

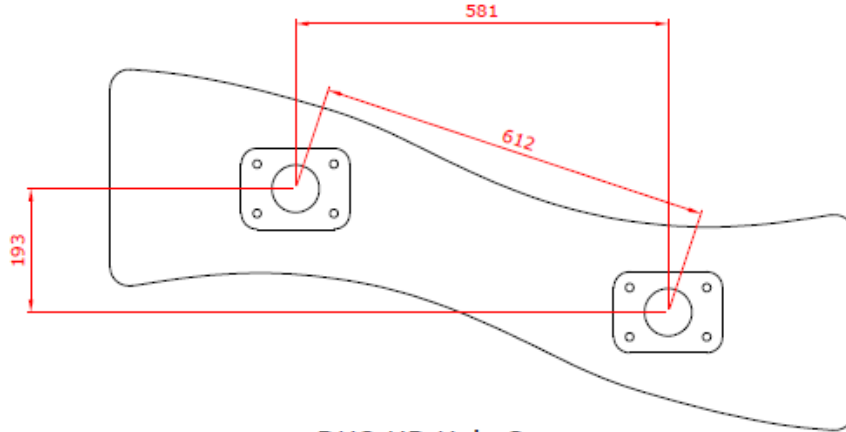

DUO HD Hole Centres

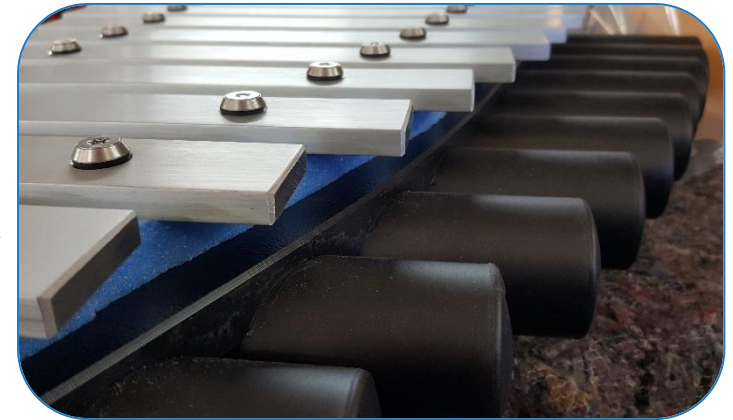

Black HDPE and Aluminium Body

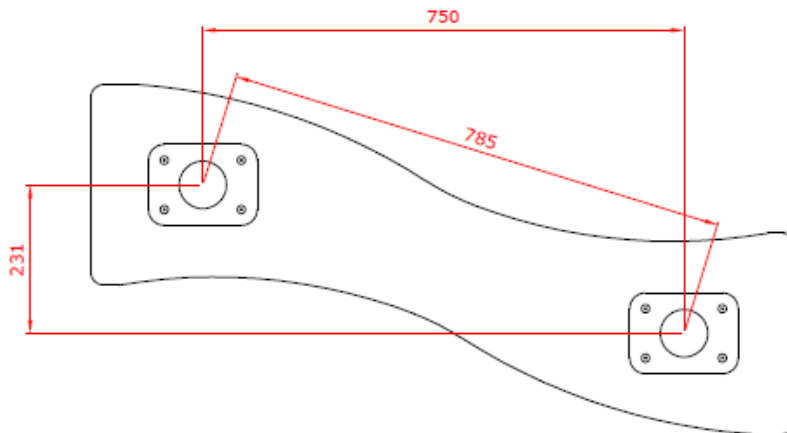

DUO SD Hole Centres



ABS Painted Body

Components:

 x4
M10x200
Threaded Bar

 x8
M10 Nut

Metric Conversion:
193mm/ 7 19/32"
231mm/ 9 3/32"
581mm/ 22 7/8"
612mm/ 24 3/32"
750mm/ 29 17/32"
785mm/ 30 29/32"



MADE IN BRITAIN

BS EN 1176



Foundations should not present a hazard. These foundations are recommended as a guide, for more information on foundation details for various surface see Part 1 of BS EN 1176.

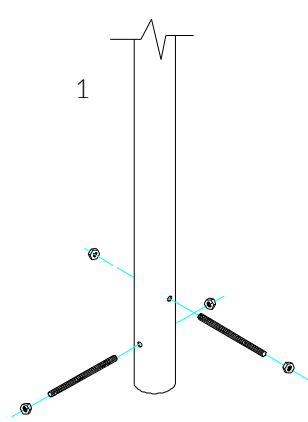

1
Insert M10x 200 Threaded bar into pre drilled holes in Ground Fixing Post

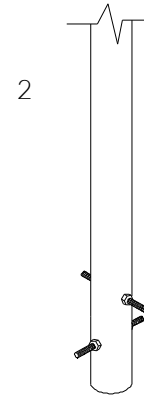

2
Fix M10x 200 Threaded bar in place using M10 Nuts

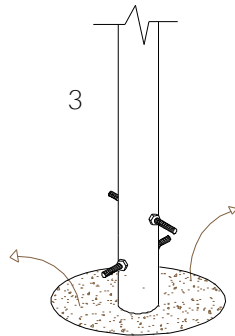

3
Excavate 2 holes with a 250mm diameter tapering down to 350mm diameter and 450mm depth

400mm min depth

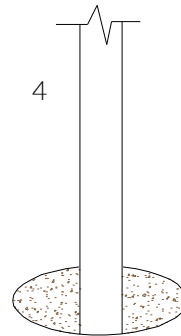

4
Compact base of hole with 50mm of aggregate. Lower ground Fix post attached to instrument into hole (check instrument straight and level before filling with concrete)

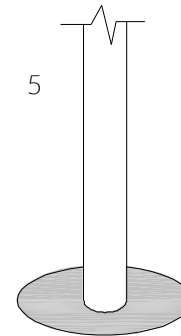

5
Fix hole with fast drying concrete to manufacturers specifications.

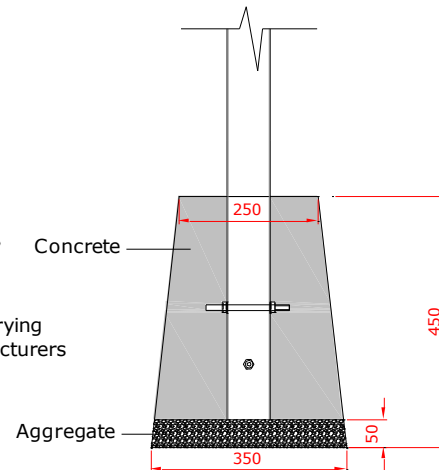

Duplicate points 1-5. Duo requires 2 Ground Fix Posts



Ground Fixed

Duo
Page 4 of 4

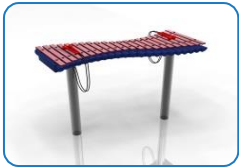

Components:



Metric
Conversion:
50mm/ 2"
250mm/ 10"
350mm/ 14"
400mm/ 16"
450mm/ 18"



MADE IN
BRITAIN

BS EN 1176